

Section Contents

LINEAR

BEARING SERIES	BEARING DESCRIPTION	PAGE
INFORMATION	LINEAR BEARINGS, GENERAL OVERVIEW	450
P / N IDENTIFICATION	LINEAR BEARINGS	460
COMPONENTS	LFS LINEAR BEARINGS	469
COMPONENTS	TS..W LINEAR BEARINGS	469
COMPONENTS	LFL LINEAR BEARINGS	469
COMPONENTS	LFCL LINEAR BEARINGS	469
COMPONENTS	LFR LINEAR BEARINGS	469
COMPONENTS	RUE LINEAR BEARINGS	469
COMPONENTS	KUSE LINEAR BEARINGS	469
COMPONENTS	KUVE LINEAR BEARINGS	469
COMPONENTS	KUVS LINEAR BEARINGS	469
COMPONENTS	KUE LINEAR BEARINGS	469
COMPONENTS	KUME LINEAR BEARINGS	469
RUE	LINEAR RECIRCULATING ROLLER BEARING AND GUIDEWAY ASSEMBLIES	470
RUE..H	LINEAR RECIRCULATING ROLLER BEARING AND GUIDEWAY ASSEMBLIES	472
RUKS	LOCKING ELEMENT	474
APLU	SHEET STEEL WIPER	476
BPLU	LUBRICATION ADAPTER PLATE	477
SMDE	MINIMAL QUANTITY LUBRICANT METERING UNIT	478
RUDS	DAMPING CARRIAGE	479
KUSE	LINEAR RECIRCULATING BALL BEARING AND GUIDEWAY ASSEMBLIES	480
KUSE..L	LINEAR RECIRCULATING BALL BEARING AND GUIDEWAY ASSEMBLIES	482
KUSE..H	LINEAR RECIRCULATING BALL BEARING AND GUIDEWAY ASSEMBLIES	484
KUSE..HL	LINEAR RECIRCULATING BALL BEARING AND GUIDEWAY ASSEMBLIES	486
APLSE	SHEET STEEL WIPER	488
AB KOL KWSE	COLLECTOR WIPER	489
BPLSE	LUBRICATION ADAPTER PLATE	490
FBALG KWSE	BELLOWS	491
KUVE	FOUR-ROW LINEAR RECIRCULATING BALL BEARING AND GUIDEWAY ASSEMBLY	492
KUVE..S,..SN, ..H	FOUR-ROW LINEAR RECIRCULATING BALL BEARING AND GUIDEWAY ASSEMBLY	494
KUVE..W,..WL	FOUR-ROW LINEAR RECIRCULATING BALL BEARING AND GUIDEWAY ASSEMBLY	496
KUE	LINEAR RECIRCULATING BALL BEARING AND GUIDEWAY ASSEMBLIES	498
KUE..H	LINEAR RECIRCULATING BALL BEARING AND GUIDEWAY ASSEMBLIES	500
APLE	SHEET STEEL WIPER	502
BPLE	LUBRICATION ADAPTER PLATE	503
FBALG KWE	BELLOWS	504
KUVS	LINEAR BALL BEARING UNITS	506
KWVK..AL	CARRIAGES	508
TKVD	GUIDEWAYS	508



Section Contents

LINEAR

BEARING SERIES	BEARING DESCRIPTION	PAGE
KUME	MINIATURE LINEAR RECIRCULATING BALL BEARING AND GUIDEWAY ASSEMBLIES	510
LFCL	TRACK ROLLER LINEAR GUIDANCE SYSTEMS WITH HOLLOW SECTION CARRIAGE	512
LFL..SF	TRACK ROLLER LINEAR GUIDANCE SYSTEMS WITH OPEN CARRIAGE	514
LFKL..SF	TRACK ROLLER LINEAR GUIDANCE SYSTEMS WITH COMPACT CARRIAGE	516
LFDL	TRACK ROLLER LINEAR GUIDANCE SYSTEMS WITH BOGIE CARRIAGE	518
LFR	TRACK ROLLERS	520
LFZ	BOLTS	521
LFE	BOLTS	522
LFZ..A1	BOLTS	523
LFS	GUIDEWAYS	524
LFS..C	GUIDEWAYS	524
LFS..F	GUIDEWAYS	524
LFS..M	GUIDEWAYS	526
LFS..N	GUIDEWAYS	526
LFS..CH	GUIDEWAYS	528
LFS..FH	GUIDEWAYS	528
LFS..R	CURVED GUIDEWAYS	530
TSNW	SHAFT AND SUPPORT RAIL UNITS	531
TSNW..G	SHAFT AND SUPPORT RAIL UNITS	532
TSUW	SHAFT AND SUPPORT RAIL UNITS	533
TSSW	SHAFT AND SUPPORT RAIL UNITS	534
TSMW	SHAFT AND SUPPORT RAIL UNITS	535
AB LFR	CAP WIPERS	536
AB W	LUBRICATION AND WIPER UNITS	536
ANS LFS	END PLATES	537
AB	LUBRICATION AND WIPER UNITS	538
ABAL	SIDE PLATES	538
PAH	END STOPS	539
KA LFS	END COVERS	540
NAD	GROOVE STRIPS	540
ABTKO LFKL	ADAPTER	541
KX	MAX ³ INCH SELF-ALIGNING LINEAR BALL BEARINGS - CLOSED	542
KXO	MAX ³ INCH SELF-ALIGNING LINEAR BALL BEARINGS - OPEN	542
KGX	MAX ³ INCH SELF-ALIGNING LINEAR BALL BEARINGS - CLOSED WITH HOUSING	544
KGXO	MAX ³ INCH SELF-ALIGNING LINEAR BALL BEARINGS - OPEN WITH HOUSING	544
KTX	TANDEM MAX ³ INCH LINEAR BALL BEARINGS - CLOSED WITH HOUSING	546
KTXO	TANDEM MAX ³ INCH LINEAR BALL BEARINGS - OPEN WITH HOUSING	546
KS	MAX ³ METRIC SELF-ALIGNING LINEAR BALL BEARINGS - CLOSED	548
KSO	MAX ³ METRIC SELF-ALIGNING LINEAR BALL BEARINGS - OPEN	548



Section Contents

LINEAR

BEARING SERIES	BEARING DESCRIPTION	PAGE
KGSG	MAX ³ METRIC SELF-ALIGNING LINEAR BALL BEARINGS - CLOSED WITH CAST 2 BOLT HOUSING	550
KGSS	MAX ³ METRIC SELF-ALIGNING LINEAR BALL BEARINGS - ADJ. CLEARANCE WITH CAST 2 BOLT HOUSING	550
KGSO	MAX ³ METRIC SELF-ALIGNING LINEAR BALL BEARINGS - OPEN WITH CAST 2 BOLT HOUSING	550
KGSAG	MAX ³ METRIC SELF-ALIGNING LINEAR BALL BEARINGS - CLOSED WITH CAST 4 BOLT HOUSING	552
KGSAS	MAX ³ METRIC SELF-ALIGNING LINEAR BALL BEARINGS - ADJ. CLEARANCE WITH CAST 4 BOLT HOUSING	552
KGSAO	MAX ³ METRIC SELF-ALIGNING LINEAR BALL BEARINGS - OPEN WITH CAST 4 BOLT HOUSING	552
KGSNG	MAX ³ METRIC SELF-ALIGNING LINEAR BALL BEARINGS - CLOSED WITH EXTRUDED HOUSING	554
KGSNS	MAX ³ METRIC SELF-ALIGNING LINEAR BALL BEARINGS - ADJ. CLEARANCE WITH EXTRUDED HOUSING	554
KGSNO	MAX ³ METRIC SELF-ALIGNING LINEAR BALL BEARINGS - ADJ. CLEARANCE OPEN WITH EXTRUDED HOUSING	556
KGSNOS	MAX ³ METRIC SELF-ALIGNING LINEAR BALL BEARINGS - OPEN WITH EXTRUDED HOUSING	556
KTSG	TANDEM MAX ³ METRIC LINEAR BALL BEARINGS - CLOSED WITH EXTRUDED HOUSING	558
KTSS	TANDEM MAX ³ METRIC LINEAR BALL BEARINGS - ADJUSTABLE CLEARANCE WITH EXTRUDED HOUSING	558
KTSO	TANDEM MAX ³ METRIC LINEAR BALL BEARINGS - OPEN WITH EXTRUDED HOUSING	560
KTSOS	TANDEM MAX ³ METRIC LINEAR BALL BEARINGS - ADJ. CLEARANCE WITH OPEN EXTRUDED HOUSING	560
KGSC	TANDEM MAX ³ METRIC LINEAR BALL BEARINGS - OPEN WITH SIDE MOUNTED HOUSING	562
KGSCS	TANDEM MAX ³ METRIC LINEAR BALL BEARINGS - ADJUSTABLE CLEARANCE WITH SIDE MOUNTED HOUSING	562
KTFS	TANDEM MAX ³ METRIC LINEAR BALL BEARINGS - CLOSED WITH SIDE MOUNTED HOUSING	564
KH	LINEAR BALL BEARINGS	566
KGHK	LINEAR BALL BEARING AND HOUSING UNITS	568
KTHK	LINEAR BALL BEARING AND HOUSING UNITS	570
KGHW	LINEAR BALL BEARING AND HOUSING UNITS	572
KGHW T	LINEAR BALL BEARING AND HOUSING UNITS	574
KN	SELF-ALIGNING LINEAR BALL BEARINGS	576
KNO	SELF-ALIGNING LINEAR BALL BEARINGS, OPEN	576
KGN	SELF-ALIGNING LINEAR BALL BEARING AND HOUSING UNITS	578
KGNS	SELF-ALIGNING LINEAR BALL BEARING AND HOUSING UNITS	578
KGNO	SELF-ALIGNING LINEAR BALL BEARING AND HOUSING UNITS	580
KGNC	SELF-ALIGNING LINEAR BALL BEARING AND HOUSING UNITS	582



Section Contents

LINEAR

BEARING SERIES	BEARING DESCRIPTION	PAGE
KTN	TANDEM LINEAR BALL BEARING AND HOUSING UNITS	584
KTNO	TANDEM LINEAR BALL BEARING AND HOUSING UNITS - OPEN	586
KTFN	LINEAR BALL BEARING AND HOUSING UNITS	588
KB	LINEAR BALL BEARINGS	590
KBO	LINEAR BALL BEARINGS	590
KBS	LINEAR BALL BEARINGS	590
KGB	LINEAR BALL BEARING AND HOUSING UNITS	592
KGBO	LINEAR BALL BEARING AND HOUSING UNITS	592
KGBS	LINEAR BALL BEARING AND HOUSING UNITS	592
KGBA	LINEAR BALL BEARING AND HOUSING UNITS	594
KGBAO	LINEAR BALL BEARING AND HOUSING UNITS	594
KGBAS	LINEAR BALL BEARING AND HOUSING UNITS	594
KTB	LINEAR BALL BEARING AND HOUSING UNITS	596
KTBO	LINEAR BALL BEARING AND HOUSING UNITS	596
PAB	PERMAGLIDE LINEAR PLAIN BEARINGS	598
PAGBA	PERMAGLIDE LINEAR PLAIN BEARINGS	600
W	SHAFTS	602
WH	SHAFTS	604
TSNW	SHAFT AND SUPPORT RAIL UNITS	605
TSWW	SHAFT AND SUPPORT RAIL UNITS	605
TSUW	SHAFT AND SUPPORT RAIL UNITS	606
TSNW..G	SHAFT AND SUPPORT RAIL UNITS	607
TSSW	SHAFT AND SUPPORT RAIL UNITS	608
TSWWA	SHAFT AND SUPPORT RAIL UNITS	609
GWH..B	SHAFT SUPPORT BLOCKS	610
GWN..B	SHAFT SUPPORT BLOCKS	611
GW	SHAFT SUPPORT BLOCKS	612
TSN	SUPPORT RAILS	613
KBZ	LINEAR BALL BEARINGS	615
KBZ..OP	LINEAR BALL BEARINGS	616
KNZ	SELF ALIGNING LINEAR BALL BEARINGS	617
KNZ..OP	SELF ALIGNING LINEAR BALL BEARINGS	618
KGNZ	SELF ALIGNING MOUNTED UNITS	619
KGNZ..OP	SELF ALIGNING MOUNTED UNITS	620
KTNZ	SELF ALIGNING TANDEM MOUNTED UNITS	621
KTNZ..OP	SELF ALIGNING TANDEM MOUNTED UNITS	622
WZ	PRECISION GROUND SHAFTS	623
WZ..PDT	PRECISION GROUND SHAFTS	624
TSWZ	SHAFT SUPPORT RAILS	625



Section Contents

LINEAR

BEARING SERIES	BEARING DESCRIPTION	PAGE
TSWZ..PD	SHAFT SUPPORT RAILS	626
TSUZ	SHAFT SUPPORT RAILS	627
TSUZ..PD	SHAFT SUPPORT RAILS	628
MLFZ	RAIL	629
LFL	CARRIAGE	630
LFSB	RAIL	630
LFKL	CARRIAGE	631
MLF..ZR	LINEAR MODULAR UNIT WITH TRACK ROLLER GUIDANCE SYSTEM AND TOOTHED BELT DRIVE	632
MKUE..ZR	LINEAR MODULAR UNIT WITH RECIRCULATING BALL BEARING GUIDANCE SYSTEM AND TOOTHED BELT DRIVE	634
MKUE..KGT	LINEAR MODULAR UNIT WITH RECIRCULATING BALL BEARING GUIDANCE SYSTEM AND BALL SCREW DRIVE	636
RUS	LINEAR ROLLER BEARING BLOCK, WITH SEPARATOR	638
RUSZ	INCH LINEAR ROLLER BEARING BLOCK, WITH SEPARATOR	640
PR	LINEAR ROLLER BEARING BLOCK, FULL COMPLEMENT	642
VUS	ADJUSTING GIBS	644
RUSV	LINEAR ROLLER BEARINGS WITH INTEGRAL ADJUSTING GIB	646
RGT	PLANETARY ROLLER SCREW	648
KGS	ROLLED THREAD BALL SCREWS	658
KGF	FLANGED BALL NUT FOR BALL SCREWS	659
KGM	CYLINDRICAL BALL NUT FOR BALL SCREWS	660
KGS	ROLLED THREAD BALL SCREW - FORM D ENDS	661
KGS	ROLLED THREAD BALL SCREW - FORM W, N AND Z ENDS	662
BF	LINEAR FLAT STEEL CAGE & ROLLERS, SINGLE ROW	663
FF	LINEAR FLAT PLASTIC CAGE & ROLLERS, SINGLE ROW, SNAP CONNECTORS	663
H	LINEAR FLAT ALUMINUM CAGE & ROLLERS, SINGLE ROW	663
HR	LINEAR FLAT ALUMINUM & PLASTIC CAGE & CYLINDRICAL ROLLERS, SINGLE ROW	663
FF..ZW	LINEAR FLAT PLASTIC CAGE & ROLLERS, DOUBLE ROW, SNAP CONNECTORS	664
H..ZW	LINEAR FLAT ALUMINUM CAGE & ROLLERS, DOUBLE ROW	664
HR..ZW	LINEAR FLAT STEEL CAGE & ROLLERS, DOUBLE ROW	664
FFW	LINEAR FLAT PLASTIC CAGE & ROLLERS, DOUBLE ROW AT 90 DEGREE BEND, SNAP CONNECTORS	665
HRW	LINEAR FLAT STEEL CAGE & ROLLERS, DOUBLE ROW AT 90 DEGREE BEND	665
HW	LINEAR FLAT ALUMINUM CAGE & ROLLERS, DOUBLE ROW AT 90 DEGREE BEND	665

General Information

LINEAR

INTRODUCTION

Many years of field experience have contributed to the optimization of INA products and systems for linear movement to meet the high demands of modern machine design; they have the following advantages:

- Very low and uniform resistance to displacement, giving improved positioning and running accuracy;
- The negative influences due to shock loading which occur in conventional rolling element guidance systems as the elements enter the load zone are reduced in INA guidance systems by means of special design features.

INA linear guidance systems have extremely high precision and operate virtually wear-free due to their rolling motion so that their high accuracy is maintained throughout the operating life.

A wide range of linear guidance systems are available, each designed for maximum rigidity. By selecting the optimum type of guidance and preloading of linear bearings, virtually any rigidity requirement can be fulfilled.

INA linear products have an extremely high load carrying capacity due to their optimum use of available space and manufacturing quality. Guidance systems for almost all load carrying requirements can be produced from the comprehensive product range.

INA Linear Roller Bearing And Guideway Assemblies Series RUE

INA linear recirculating roller bearing and guideway assemblies of series RUE are high accuracy, ready-to-assemble linear guidance units which can take high loads. They have a full complement rolling element system which is preloaded as standard and allows high running and positioning accuracy.

The basic static and dynamic load ratings of RUE assemblies are nearly twice that of comparable ball and guideway assemblies.

The rigidity of recirculating roller bearing and guideway assemblies is considerably higher than that of ball bearing and guideway assemblies. While some competitors argue that the rigidity can be improved by means of high preloads on the recirculating ball system, this is entirely at the expense of the life.

The linear recirculating roller bearing and guideway assembly also has a high crash safety.

The carriage is sealed on all sides. As opposed to the competition, the whole body of the guideways is ground which provides optimum sealing.

When these assemblies are used in machine tools, brass closing plugs are particularly advantageous.

The RUE unit is interchangeable with the ball bearing and guideway assemblies of the same section height produced by our competitors but they have considerably higher load ratings and rigidity. Due to the technical advantages of the roller system, the next smallest RUE unit can often be used compared to ball bearing and guideway assemblies.

The carriage can be fixed from above or below with 6 screws. The guideway has twice as many screws as the guideways produced by the competitors. Recirculating roller bearing and guideway assemblies may be combined with the damping carriage RUDS to counteract vibration, giving the benefits of both a sliding and a rolling guidance system. Plastic deformation of the rolling elements no longer occurs as the smaller damping gap and the increased surface area of the damping carriage reduce the specific contact load considerably.

General Information

LINEAR

Linear Recirculating Ball Bearing And Guideway Assemblies Series KUSE

Six-track linear recirculating ball bearing and guideway assemblies of series KUSE have the highest load rating of any recirculating ball bearing guidance system with the same envelope dimensions, and allow very high accelerations and velocities. Linear ball bearing and guideway assemblies of series KUSE should be classified between the traditional linear ball bearing and linear roller bearing guideway assemblies.

Linear ball bearing and guideway assemblies of series KUSE derive their high load carrying capacity from the six tracks of preloaded balls. They can take loads from all directions and moments about all axes. The low friction characteristics of this new linear recirculating ball system allows very high accelerations and velocities.

Linear Ball Bearing And Guideway Assemblies Series KUVS

INA linear guidance systems with recirculating ball bearing units, series KUVS, are four row linear guidance systems. Two of the main features of these assemblies are wide support distances and adjustable bearing clearance.

Linear recirculating ball bearing units of series KUVS have a high load carrying capacity in spite of their small boundary dimensions. They run on guideways of series TKVD with raceways on one or both sides. These units can be screwed into a carriage KWVK..AL which can form a four row linear ball bearing and guideway assembly when combined with the TKVD guideways.

INA Linear Ball Bearing And Guideway Assemblies Series KUE

INA linear ball bearing and guideway assemblies are ready-to-assemble linear guidance systems. They consist of one or more carriages on a guideway TKD. Linear ball bearing and guideway assemblies of series KUE have a four point contact recirculating ball system.

Due to their special features, INA linear recirculating ball bearing and guideway assemblies can meet the demands of modern guidance designs:

- Accuracy
INA linear ball bearing and guideway assemblies are extremely accurate rolling bearings. They are clearance-free and operate with extremely low friction and completely free from stick-slip.
- High load carrying capacity and rigidity
INA linear ball bearing and guideway assemblies have an extremely high load carrying capacity and rigidity for their dimensions.
- Load directions
INA recirculating linear ball bearings can take loads in all perpendicular directions and moments about all axes. They need only one guideway for fixing: counterstay designs are therefore superfluous.
- Low section height
INA linear ball bearing and guideway assemblies have an extremely low section height. This allows a very compact design of guidance system.

In addition, KUE assemblies have the following important features:

- High running and positioning accuracy (clearance-free)
- High reliability
- Easy mounting
INA linear ball bearing and guideway assemblies are supplied ready for assembly. This allows economical designs of guidance systems.
- Interchangeability
The components of a linear ball bearing and guideway assembly can be interchanged within the same preload and accuracy class.

General Information

LINEAR

INA Track Roller Linear Guidance System Series LF

Due to its modern and innovative design, the INA track roller linear guidance system offers the following advantages:

- **Straightforward modular design**
The modular construction of the INA track roller linear guidance system allows individual guidance elements to be combined as required. Depending on the requirements, complete units may be used or variants may be produced with single guideways on the inside or outside combined with different rollers.
- **Robust, wear-resistant, reliable system**
Vertical and horizontal motion can be achieved even in contaminated environments. Reliable operation and a long operating life are ensured, together with low maintenance requirements.
- **High load carrying capacity**
Loads can be taken from all directions and moments about all axes. Depending on the load case, different guidance elements with differing high load carrying capacities are available to the user.
- **High accuracy**
Due to the production process, the guideways have a high accuracy, providing clearance-free and low-friction operation. LF systems can be used in any mounting position.
- **Unlimited stroke at high traverse speeds**
The INA track roller linear guidance system allows linear motion of any length and speeds up to 10 m/s.
- **Straightforward assembly**
INA track roller linear guidance systems are supplied ready for mounting. The user has the option, depending on the guideway type, of fixing from above or below. The premounted carriage can be set clearance-free. The system can be matched to the customer's specific requirements.
- **High wear resistance due to the optimized profile of the track rollers and the rolled precision steel shafts hardened to HRC 60**
- **Long life**
- **The load carrying capacity can be considerably increased if required by adding more track rollers**
- **Relubrication facility**
- **The individual components are easily interchangeable**
- **Systems have low mass due to the use of anodized aluminium components**
- **Systems are also available in corrosion resistant and black anodized versions**
- **There are many potential applications in almost all areas**
- **The standard version is readily available from stock**
- **The track rollers are lubricated for life**
- **Various sealing options and accessories are available**

General Information

LINEAR

INA Linear Ball Bearings Series KH

INA linear ball bearings of series KH are linear recirculating ball bearing units of very small radial section height. They consist of a drawn and hardened outer cup and a plastic cage. The outer cup, cage and balls form a closed linear bearing which is ready to assemble. These units are suitable for applications where long travel distances, low space requirements and predominantly maintenance-free operation are required.

Linear ball bearings of series KH have the following advantages:

- Optimum price/performance ratio
- Very small radial section height
- Axial location is not required
- Double lip contact sealing rings on KH...P and KH...PP
- Optimum sealing
- Lubricant is retained in the bearing
- Relubrication via slots in the ball recirculation channel
- Long operating life
- Operating temperature up to 120°C
Cage: polyamide 66-GK
Sealing rings: polyester elastomer

INA ball bearings are superior bearings not only in terms of their resistance to temperature but also in their other features such as:

- Smooth running
- Load carrying capacity
- Rigidity

Good rigidity is achieved in all directions due to the uniform spacing of the rows.

INA Linear Ball Bearings Series KN/KS MAX³

INA linear ball bearings of series KN, KNO, KS and KSO are linear recirculating ball bearing units which can compensate for misalignments due to their special design.

Linear ball bearings of this series consist of a cage and several load plates. The high-strength plastic cage guides the balls. The hardened load plates have a ground profile on the raceway side.

The KN/KS series offer:

- Ground races for smoothest operation
- Self aligning in any housing
- Completely interchangeable with other standard makes
- Lower noise level
- Lighter weight
- Wiper seals float with the bearing
- Linear ball bearings KNO..PP with all-around sealing have additional reinforced longitudinal seals
- Cost effective bearings for round shaft rails

In addition, the KS offers:

- Larger load capability due to increased number of ball rows
- Greater misalignment capability
- Longer bearing life due to the internal lubrication reservoirs

General Information

LINEAR

INA Linear Ball Bearings Series KB

INA linear ball bearings of series KB consist of a hardened and ground outer ring and a cage in which the balls are guided. The balls in the return zones are held in place by spring elements. This ensures that even heavily loaded or preloaded bearings have a uniform, low resistance to displacement.

INA linear ball bearings of closed (KB), adjustable (KBS) and open version (KBO) have 4 to 6 rows of balls to support the load and are used where high precision and load carrying capacity are required.

Linear ball bearings of series KBS have a split outer ring which allows the operating clearance to be adjusted.

Linear ball bearings of series KBO have a segment cut out of the outer ring: they are suitable for applications with shafts with continuous support.

Linear ball bearings of series KB, KBS and KBO can be relubricated.

The ground outside diameter on the linear ball bearings series KB are suitable as raceways for rolling bearings so that bearing units for linear and rotary motion can be created.

The special recirculation design provides a uniform, low resistance to displacement with extremely smooth running even in highly loaded and preloaded linear ball bearings.

Bearings of series KB are completely interchangeable with the bearings of our competitors.

INA Shafts Series W, WH, WZ

INA shafts of series W, WH and WZ are suitable for guidance systems with closed, protected linear bearing units and are used in a wide range of applications in the construction of equipment and automatic machinery.

- INA shafts are surface hardened, precision ground and made from high grade steels.
- High material quality
- High surface hardness and surface quality
- High dimensional and geometrical accuracy ensure excellent running characteristics.
- Steel shafts are available in standard lengths ex stock and can be cut to the customer's requirements. They can be produced with various end configurations and other machined features.
- Special versions are available in other materials, e.g. corrosion-resistant steel.
- Shafts of 5 mm diameter are available in lengths up to about 3700 mm and shafts of 6 mm diameter and above in lengths up to about 4000 mm.
- INA can supply composite shafts where the length required exceeds the maximum single piece length.
- Special versions are available on request with other tolerances and special surface coatings and as unhardened shafts.

Shafts and support rails of series TSCW, TSNW, TSSW, TSUW, TSWW and TSWWA complete the INA linear range and remove the need for expensive, time consuming customer designs.

Support rails have the following advantages:

- They prevent flexing of the shaft
- They ensure correct functioning of the linear guidance system
- Low section height
- High rigidity

General Information

LINEAR

INA Linear Ball Bearings Series KBZ

Linear ball bearings of series KBZ and KBZ..OP consist of a hardened and ground solid outer ring and a retainer. The outer ring is machined from high-carbon bearing steel. The retainer is manufactured from a high strength engineered resin. Series KBZ..OP have a segment removed from the outer ring for applications with supported shafts.

Series KNZ/KX MAX³

Linear ball bearings of series KNZ.. and KX.. consist of a precision molded retainer of a high strength engineered resin and hardened and ground bearing races. Series KNZ..OP.. and KXO.. bearings have a segment removed for applications requiring supported shafts.

The KNZ/KX series offer:

- Ground races for smoothest operation.
- Self Aligning in any housing.
- Completely interchangeable with other standard makes.
- Lower noise level.
- Lighter weight.
- Wiper seals float with the bearing.
- Cost effective bearings for round shaft rails.

In addition, the KX offers:

- Larger load capability due to increased number of ball rows
- Greater misalignment capability
- Longer bearing life due to the internal lubrication reservoirs

Linear Recirculating Ball Bearing And Guideway Assemblies Series KUVÉ

The four-row linear recirculating ball bearing and guideway assembly KUVÉ comprises a total of six carriage cross-sections. The four rows of balls are preloaded. The unit has a high load carrying capacity; it can take loads from all directions and moments about all axes.

The special design of the recirculating ball system ensures low resistance to displacement and allows high velocities and accelerations.

General Information

LINEAR

Linear Modular Units Series MLF

The linear modular unit MLF allows small to medium loads to be moved with a high positional accuracy at speeds up to 7.5m/s^1) and with a maximum acceleration of 40m/s^2 ¹⁾. When combined with a suitable control drive, a high repeatability can be achieved, usually within $\pm 0.08\text{ mm}$.

The profiled support rails, which have high bending and torsional rigidity, allow the unit to operate without supports, even on longer modular units.

All the aluminium components are anodized.

A corrosion resistant execution is also available: suffix VA.

Design

- Profiled support rail LFS..M consisting of an anodized aluminium rail with hardened and ground steel rods inlaid on both sides. T-grooves provide various installation possibilities.
- Compact carriage in an enclosed design with integral toothed belt tensioner on both sides, lubrication and wiper unit. The carriage can be set clearance-free by means of two eccentric bolts.
- Return units with integral brush wipers and ball bearings which are lubricated for life.

Linear Modular Units Series MKUE

INA linear ball bearing and guideway assemblies are used in the linear modular units series MKUE. They are preloaded and operate virtually free from stick-slip.

The guidance accuracy of MKUE linear modular units is increased by machining the guideway seating surfaces on the support rail.

The INA linear modular unit with recirculating ball guidance system allows medium to high loads to be moved quickly and with a very high guidance accuracy.

The drive is via either a toothed belt or a ball screw.

Maximum traverse speeds are:

Toothed belt drive 3 m/s

Ball screw drive 1.73m/s

When the toothed belt drive is combined with a suitable control drive, a high repeatability can be achieved, usually within $\pm 0.08\text{ mm}$.

The profiled support rails, which have high bending and torsional rigidity, allow the unit to operate without supports, even on longer units.

All the aluminium components are anodized.

Design

- Profiled support rail made from anodized aluminium with integral ball bearing and guideway assembly KUE. T-grooves provide various installation possibilities.

Linear Modular Unit MKUE 25 ZR..N

- Carriage with two T-grooves (with threaded holes if required) and integral belt tensioners on both ends
- Return unit with ball bearing lubricated for life.

Linear Modular Unit MKUE 25 KGT

- Carriage with threaded holes
- Preloaded double nut for leads of 5 and 10 mm. Accuracy $50\text{ }\mu\text{m}/300\text{ mm}$
- INA axial angular contact ball bearings series ZKLF are used for the spindle bearing arrangements: the bearings are greased for life
- Bellows are used to protect the ball screw spindle and the KUE system.

¹⁾ These values are reduced when bellows are used.

General Information

LINEAR

INA Linear Roller Bearings Series RUS

INA linear roller bearings are manufactured in several basic types and meet the highest technical demands. Linear recirculating roller bearing systems are suitable for linear guidance systems in machine tools where high guidance and positioning accuracy with long strokes are required.

Linear roller bearings have the following advantages:

- Very high accuracy
- Increased compressive rigidity
- High load carrying capacity
- High functional reliability
- Very low frictional values compared to other linear guidance systems
- Very smooth running due to the special design of the supporting elements with compensation for bounce

Due to their robustness, linear roller bearings of series PR are also suitable for use at high temperatures as well as for extremely high velocities and accelerations.

With INA linear roller bearings of series RUSV..KS, there is no need for a separate adjusting gib. This gives advantages including:

- Fewer components
- Low section height
- Quicker, simpler mounting

INA also supplies a setting device for exact, repeatable, quick and straightforward adjustment of preload in linear roller bearings.

INA Adjusting Gibs Series VUS and VUSZ

INA Adjusting Gibs of series VUS and VUSZ are used for height adjustment or preloading of linear roller bearings. They consist of two ground wedges which are guided together by a central key. A plate fixed on one end face supports the adjusting screw and the locking screw. Lubrication ducts in the adjusting gibs allow for the lubrication of the linear bearings through the rolling element return zone in their supporting face.

General Information

LINEAR

INA Planetary Roller Screws

Series RGT

The most significant advantage of these units over ball screws is the increased number of contact points per unit volume which provides a high load carrying capacity. The specific contact load of a roller screw drive is lower and the life longer compared to ball screw drives with the same dimensions.

Compared to the more widespread ball screw drives, planetary roller screws have greater rigidity, lower axial clearance and higher limiting speeds which are about three times those of ball screw drives. RGT units are very compact and robust, require only a small amount of space, and large ball screw drives can be replaced by small RGT units. Straightforward mounting and dismantling allow the nut to be mounted where access is difficult.

- Low sensitivity to shock loading
- High functional reliability under extreme conditions
- Extremely high displacement speeds
- Low internal friction — no stick-slip, high efficiency (up to 93%).

Excellent positioning and repeat accuracy throughout the operating life. Extremely accurate positioning is possible (2 μm) due to the small lead (1 mm) with very small advance movement. At high displacement speeds, a high positioning accuracy can be achieved with a large lead.

Special machining operations (e.g. shortening a spindle) can be quickly carried out.

The optimum solution for a particular application can be achieved with special setting of the nut e.g. reduction of the frictional moment.

INA planetary roller screws, Series RGT, basically consist of a screw (shaft) and a roller nut. Several planetary rollers are arranged parallel to the axis between the screw and the roller nut.

Roller Nut

The roller nut can be supplied split or as one piece. The two halves of the split roller nut (**9**), see next page, are held together by the key (**7**). During installation of the planetary roller screw the roller nut is preloaded. A shim (**8**) is used to control the preload. The one-piece roller nut cannot be preloaded.

Internally geared rings (**4**) are situated in the ends of the roller nut engaging with the external gearing provided at each end of the planetary rollers (**5**). The spacing of the planetary rollers, is provided by the carrier plates (**3**) which also function as labyrinth seal. The plates are retained by the snap rings (**2**).

Planetary Rollers

The planetary rollers (**5**) have a journal at each end which are guided by the holes of the carrier plates. The geared ends of the planetary rollers mesh with the internally geared rings in the nut. The planetary rollers have a single-start thread with a crowned flank. This allows the stresses created by the thread meshing to be distributed on larger ellipses which also reduce the harmful edge stresses. The planetary rollers rotate slip-free in the roller nut. They have no axial movement relative to the roller nut as the axial travel increments at the points of contact between both elements are equal.

Screw Shaft

Screws are manufactured from surface hardened, case hardening steel. The thread angle is 90 degrees. Screws in standard design are available with a nominal diameter d_0 from 5 mm to 20 mm. The standard ends configuration prescribes a straight journal on the floating side and provision for lock nut and driving system on the locating side. The screws are available in different lengths. Strokes from 25 mm to 1200 mm are possible, depending on the nominal diameter.

Screws with a nominal diameter d_0 between 24 and 63 mm are special designs. Their dimensions are pre-determined by the following dimension tables. The largest possible screw diameter d_0 is 250 mm.

All screws are available with custom tailored ends configuration.

General Information

LINEAR

Special Request Variations

INA planetary roller screws are available upon request in the following special designs:

- One-piece roller nut (not preloaded, higher load ratings, small axial clearance)
- Roller nut with flanges, middle or side flange

INA Planetary roller screws are also available upon request with:

- Left hand thread
- Inch pitch thread
- Hollow shaft

If aggressive media is acting on the planetary roller screw, corrosion resistant material should be chosen. Contact INA for details.

Wipers

If planetary roller screws are subject to heavy contamination, the roller nut can be equipped with wiper seals upon request.

DESIGN OF THE INA PLANETARY ROLLER SCREW WITH SPLIT ROLLER NUT

- | | |
|---|------------------------|
| 1 | SCREW (SHAFT) |
| 2 | SNAP RING |
| 3 | CARRIER PLATE |
| 4 | INTERNALLY GEARED RING |
| 5 | PLANETARY ROLLER |
| 6 | LOCATING PIN |
| 7 | KEY |
| 8 | SHIM |
| 9 | ROLLER NUT |

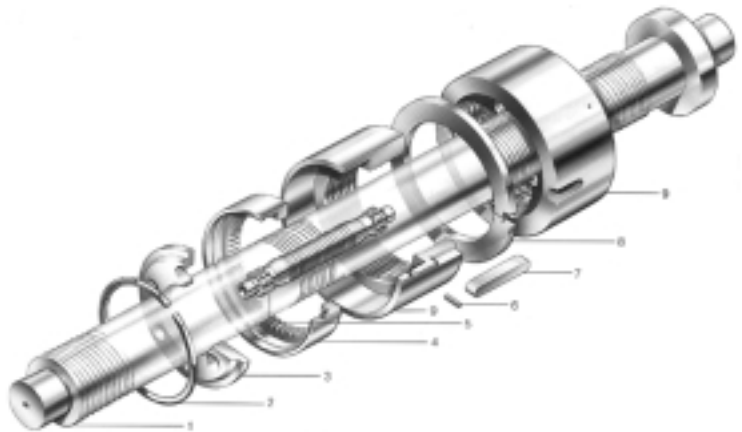

Part Number Identification

LINEAR

LINEAR RECIRCULATING ROLLER BEARING & GUIDEWAY ASSEMBLY

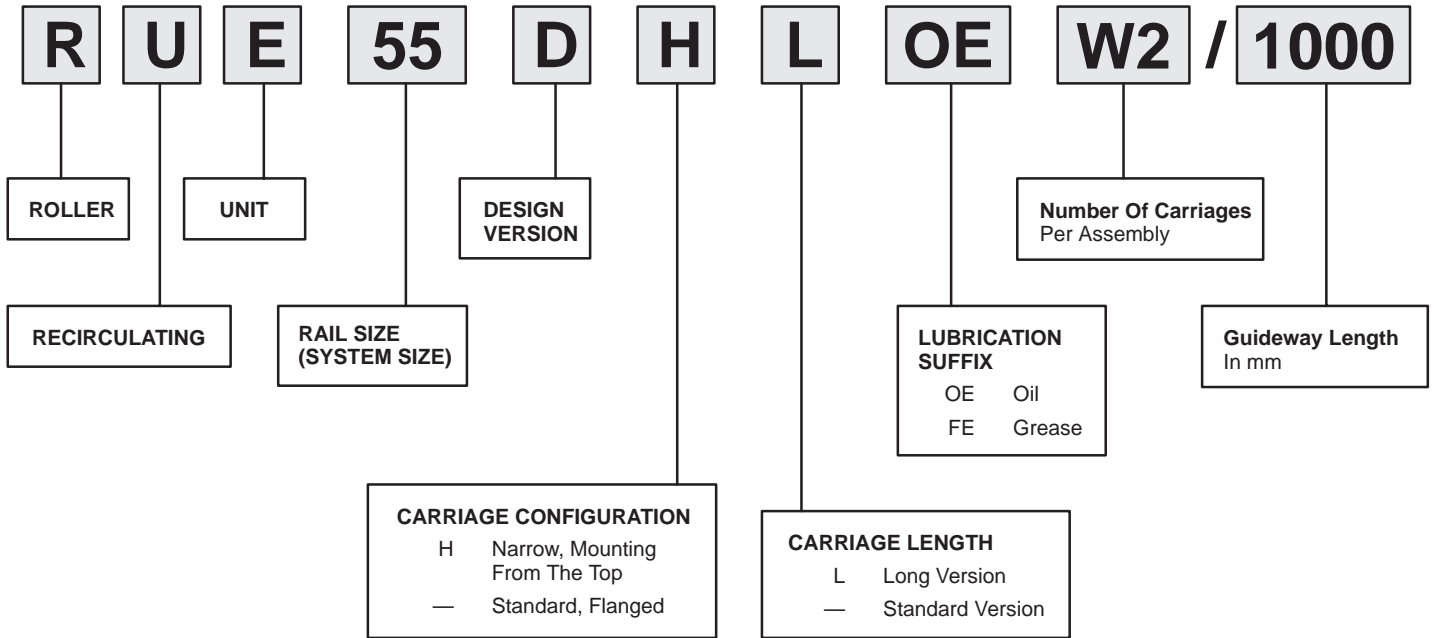

Part Number Identification

LINEAR

LINEAR RECIRCULATING ROLLER BEARING & GUIDEWAY ASSEMBLY

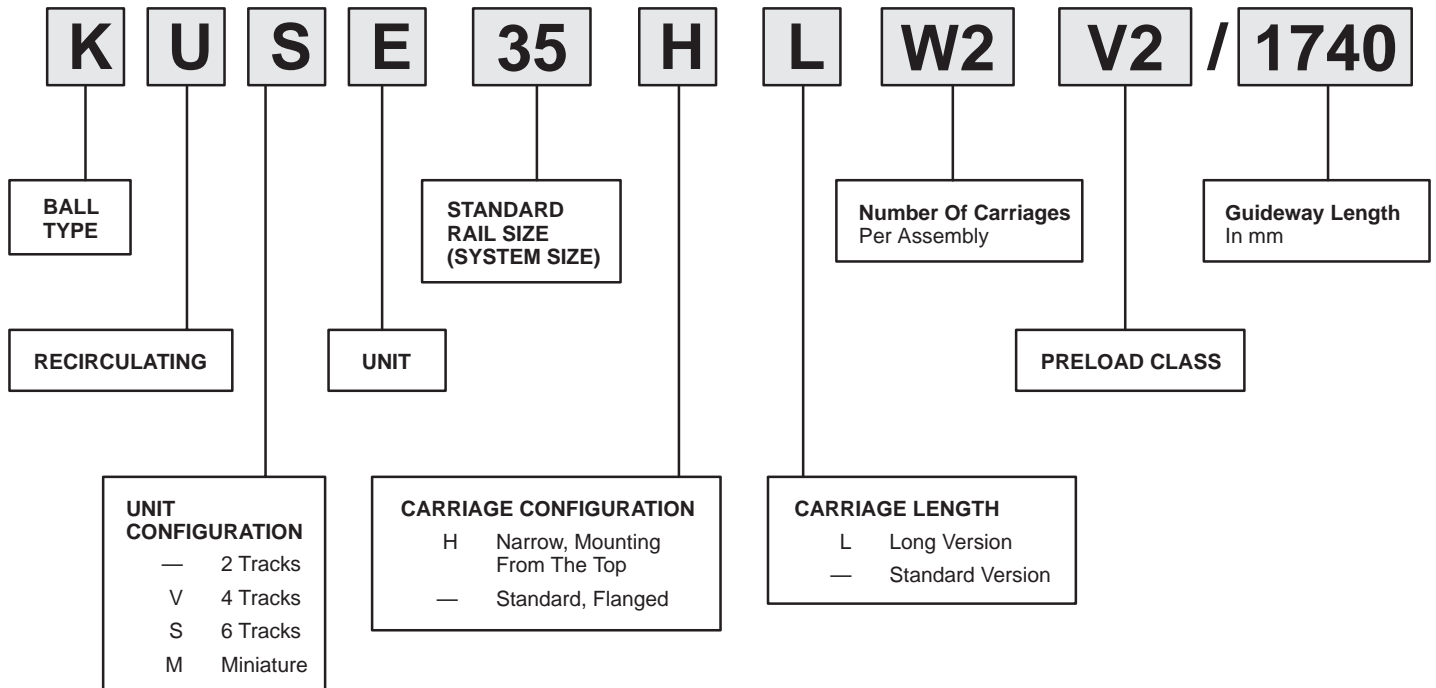

Part Number Identification

LINEAR

LINEAR GUIDANCE SYSTEMS

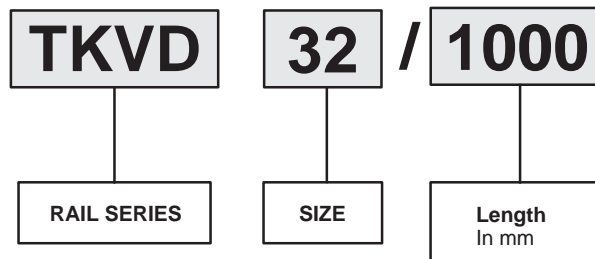
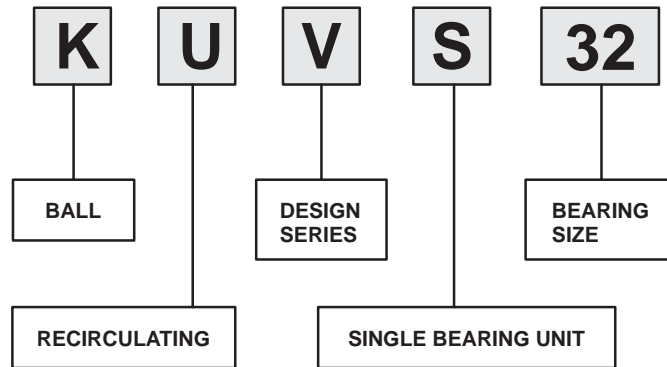

Part Number Identification

LINEAR

LF CARRIAGES & RAILS

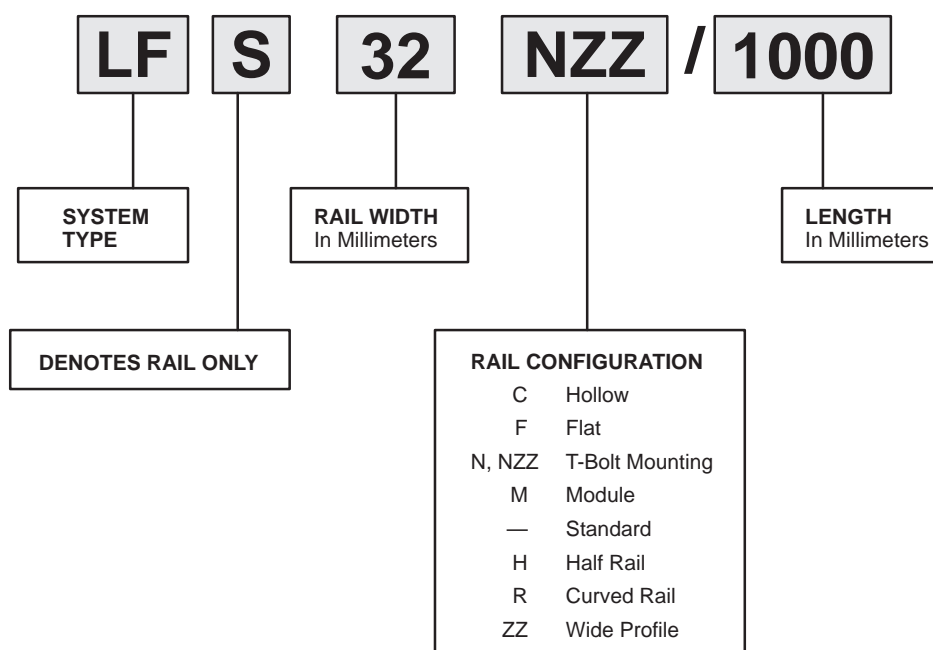
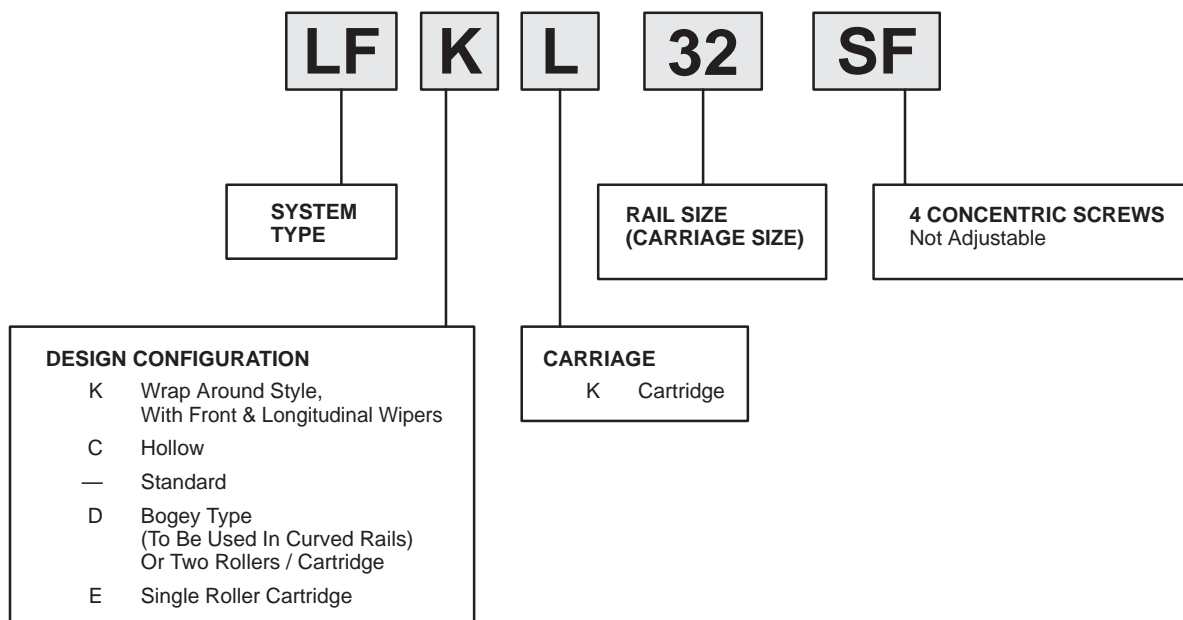

Part Number Identification

LINEAR

MAX³ INCH & METRIC BEARINGS & HOUSING UNITS

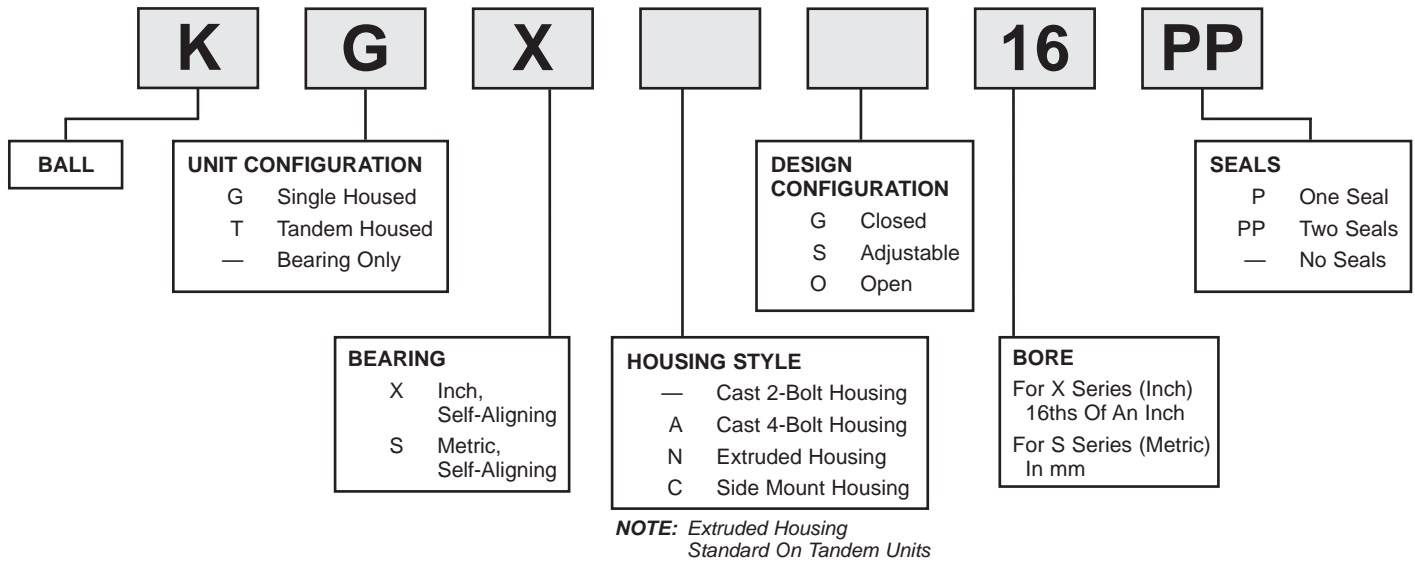

METRIC HOUSING UNITS

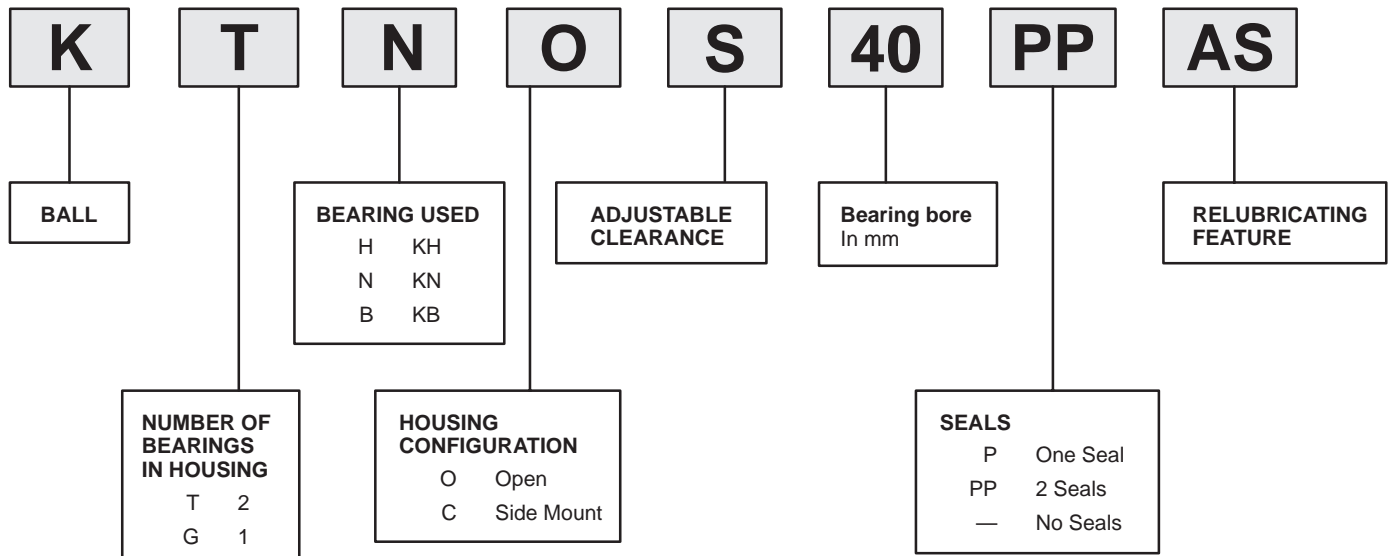

Part Number Identification

LINEAR

INCH BEARINGS & HOUSING UNITS

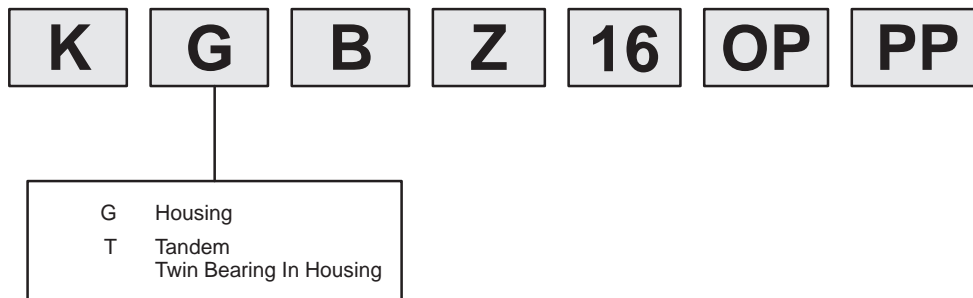
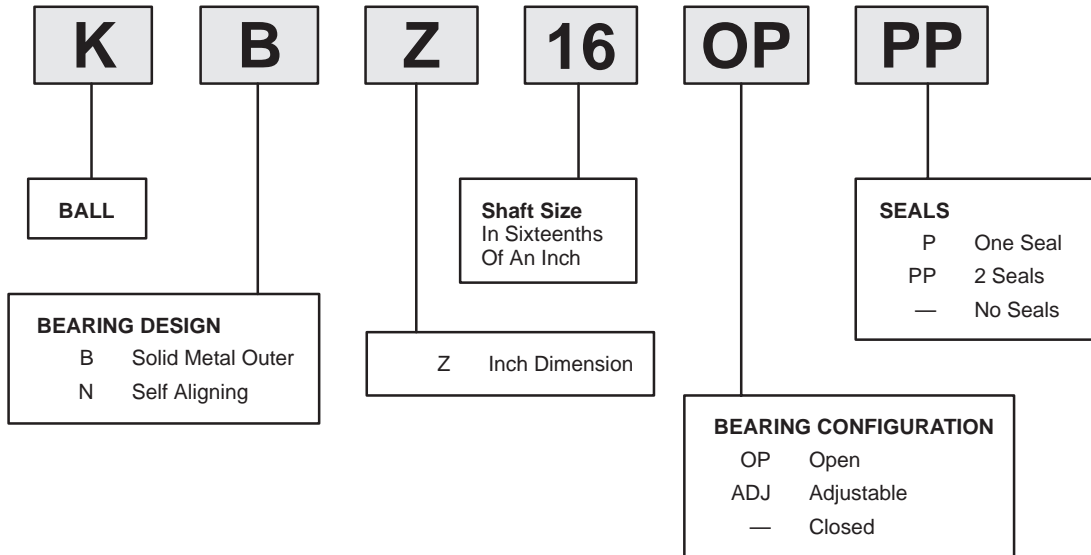

Part Number Identification

LINEAR

SHAFTS (METRIC & INCH)

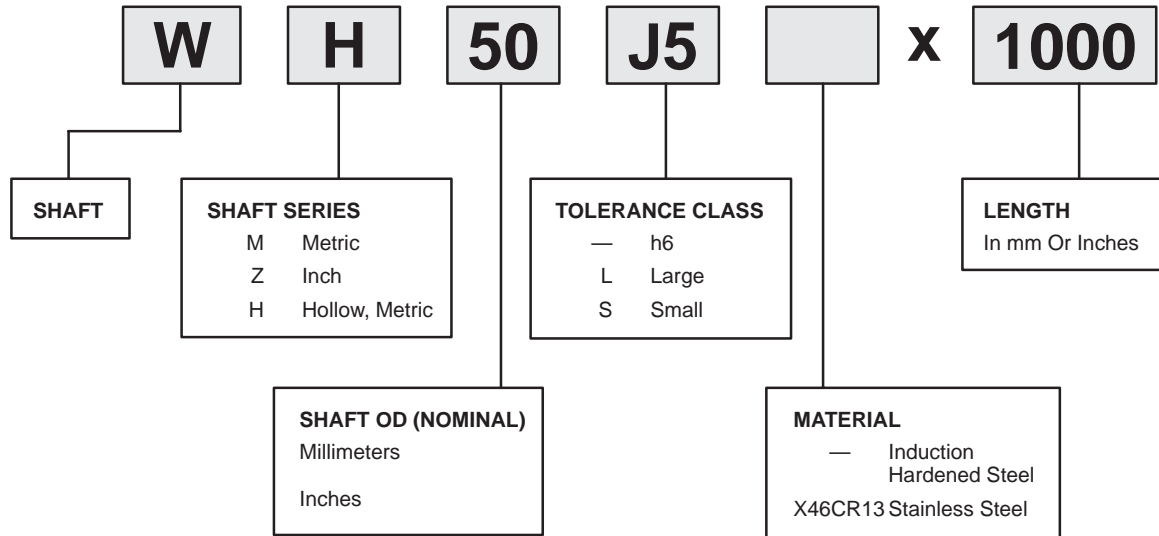

SUPPORT RAILS (METRIC & INCH)

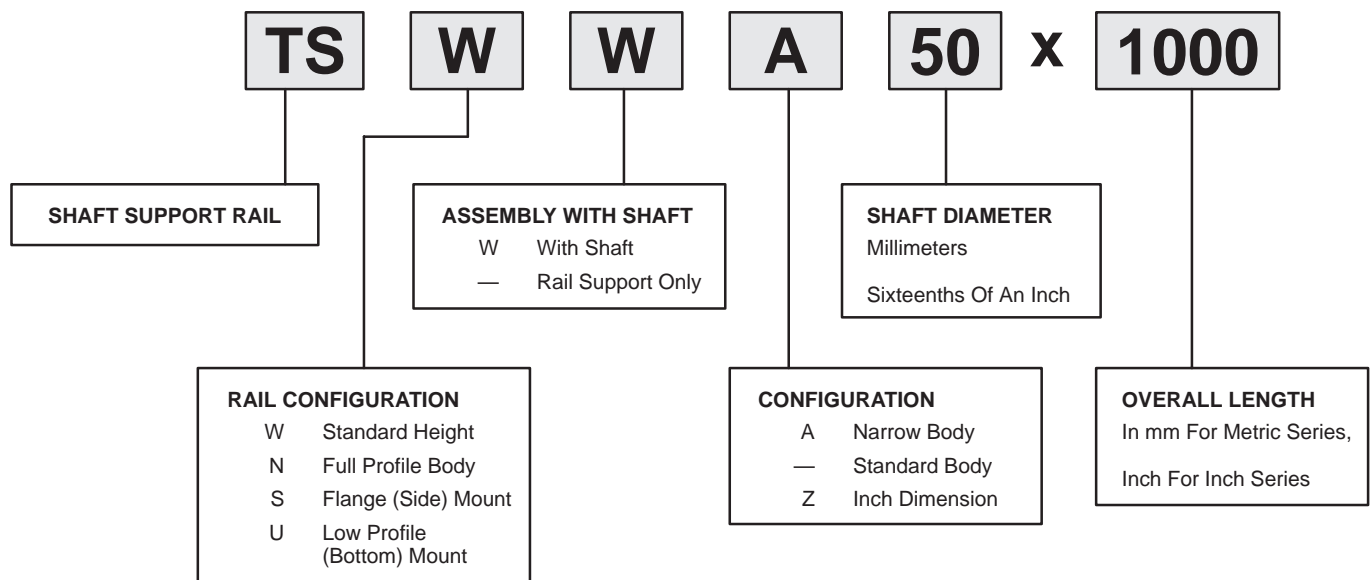

Part Number Identification

LINEAR

METRIC BALL BUSHINGS

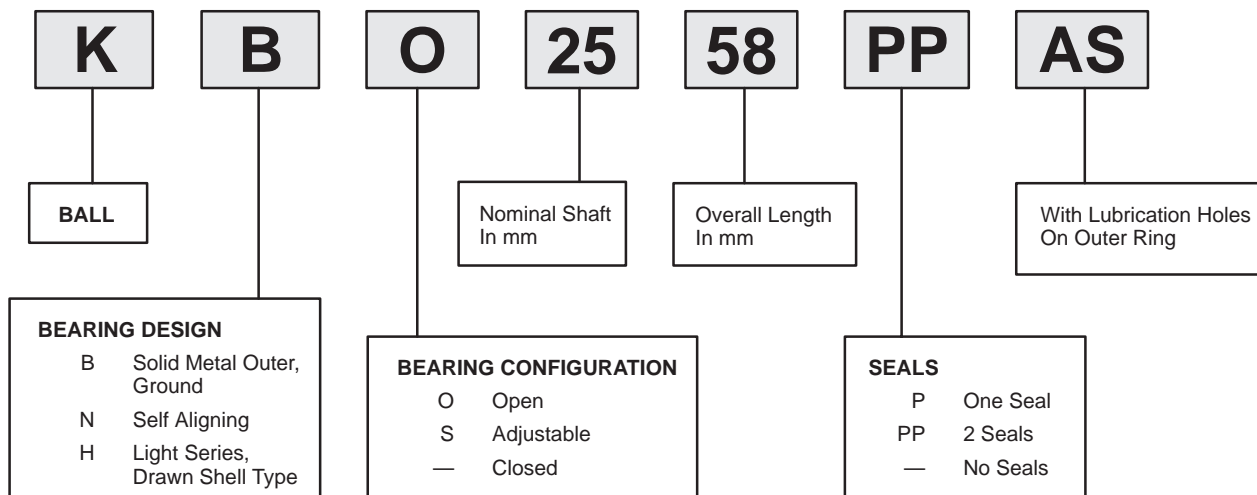

PLANETARY ROLLER SCREWS

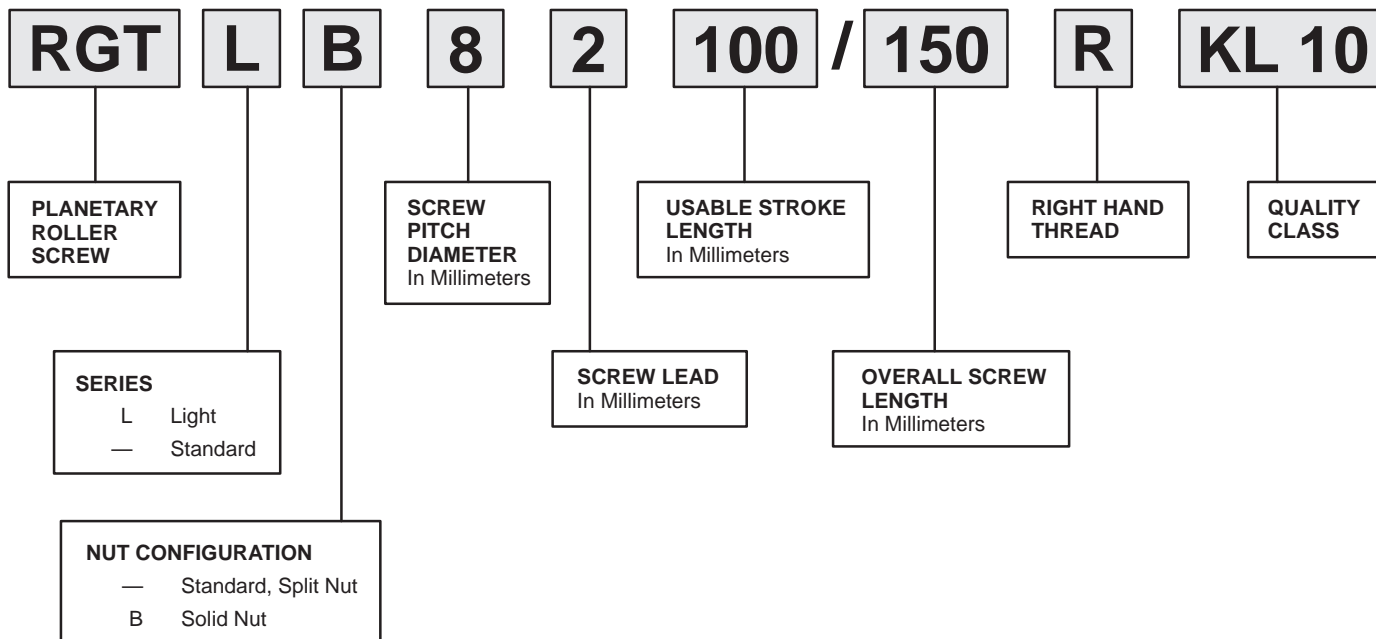

Part Number Identification

LINEAR

BALL NUTS

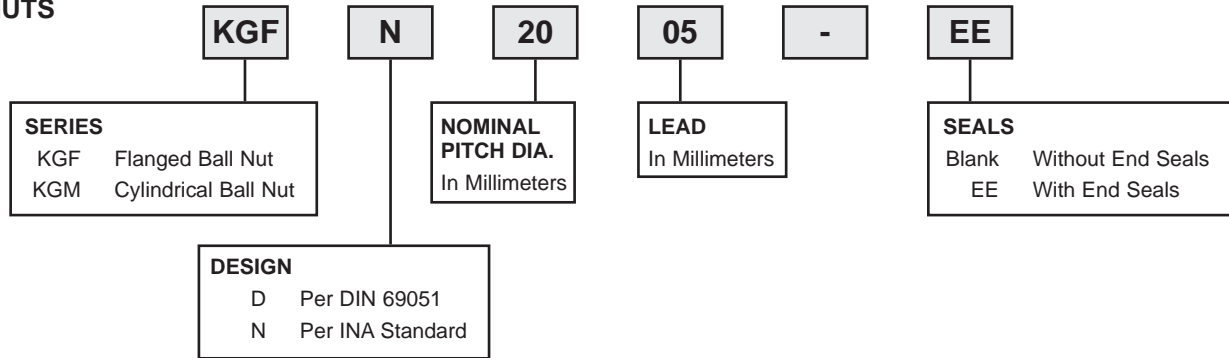

BALL SCREW SHAFT

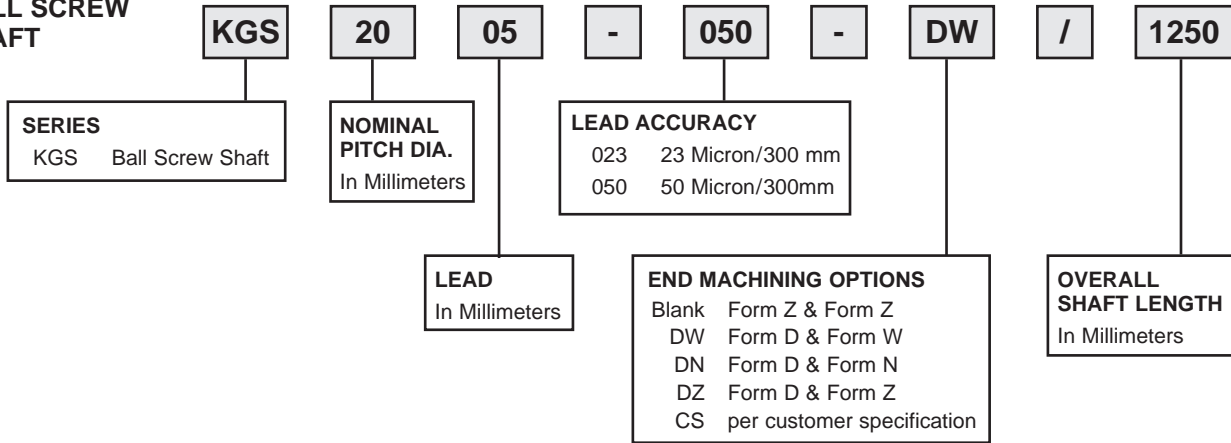

BALL SCREW ASSEMBLY

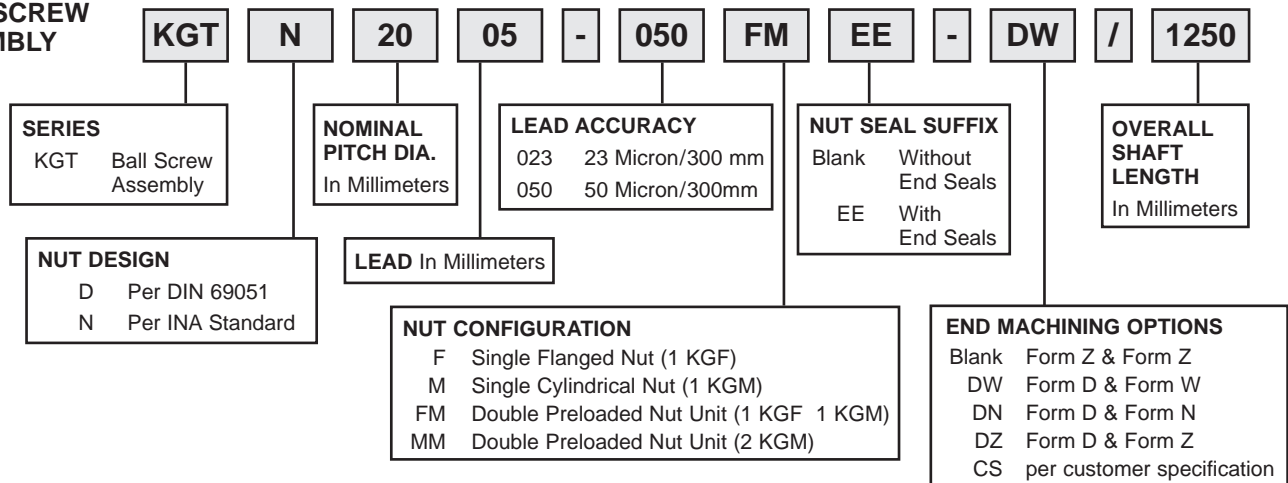

Part Number Identification

LINEAR

COMPONENT / FAMILY

LFS, LFS..C, M, TS..W, LFL, LFCL, LFR..

COMPONENT	FAMILY					
	LFS	LFS..C,M	TS.W	LFL	LFCL	LFR..
Cap wiper	—	—	—	—	—	AB LFR
Lube & wiper unit	—	—	AB..W	AB/AB..LFL	—	AB..W
Side plates	—	—	—	ABAL	—	—
End stops	PAH	—	—	—	—	—
End plate	—	ANS LFS	—	—	—	—
End Cover	—	KA LFS..C,M,CH	—	—	KA LFS..CL	—
Cover strip	—	NAD	—	—	—	—
Measuring system	LMS	LMS	LMS	—	—	—

RUE, KUSE, KUVE, KUVS, KUE, KUME

COMPONENT	FAMILY					
	RUE	KUSE	KUVE	KUVS	KUE	KUME
Cap wiper	—	—	—	—	—	AB LFR
Closing plugs (plastic)	KA..TN	KA..TN	KA..TN	KA..TN	KA..TN	KA..TN
Closing plugs (brass)	KA..M	KA..M	—	—	KA..M	—
Mounting rail	MSX	MKSD	MKVD	—	MKD	MKMD
Hydraulic mounting device	MVH	—	—	—	—	—
Cover strip	ABDU	ADBSE	—	—	—	—
Sheet steel wiper	APLU	APLSE	APLVE	—	APLE	—
Spring loaded scraper	—	AB KOL KWSE	—	—	—	—
Braking element	RUKS..D	—	—	—	—	—
Lube adapter plate	BPLU	BLSE	—	—	BPLE	—
Grease lube adapter	—	SMAD KFE	SMAD KFE	—	SMAD KFE	—
Oil lube adapter	—	SMAD KOE	SMAD KOE	—	SMAD KOE	—
Lube metering unit	SMDE	—	—	—	—	—
Damping carriage	RUDS	—	—	—	—	—
Bellows	—	FBALG	—	—	FBALG	—



Linear Recirculating Roller Bearing And Guideway Assemblies

RUE..D, RUE..DL, RUE 65 L SERIES

For details on part numbers, descriptive suffixes and various technical references, please refer to front of this section.

For engineering or technical information contact your local sales representative or call Distributor Sales (800)523-6572 or Linear Sales (800)462-3399.

Linear roller bearing and guideway assembly Grease Lubrication PART NUMBER	Linear roller bearing and guideway assembly Oil Lubrication PART NUMBER	CARRIAGE ¹⁾ PART NUMBER	CARRIAGE MASS kg	GUIDEWAY PART NUMBER	GUIDEWAY MASS kg/m	GUIDEWAY Closing Plugs ²⁾	COVERING STRIP	L ³⁾ mm	H mm	A mm	C ⁴⁾ mm
RUE 35 D FE	RUE 35 D OE	RWU 35 D	2.0	TSX 35 D	5.9	KA 15	ADB 18	2960	48	100	120
RUE 35 D L FE	RUE 35 D L OE	RWU 35 D L	2.7	TSX 35 D	5.9	KA 15	ADB 18	2960	48	100	143
RUE 45 D FE	RUE 45 D OE	RWU 45 D	3.3	TSX 45 D	9.4	KA 20	ADB 23	2940	60	120	141
RUE 45 D L FE	RUE 45 D L OE	RWU 45 D L	4.4	TSX 45 D	9.4	KA 20	ADB 23	2940	60	120	175
RUE 55 D FE	RUE 55 D OE	RWU 55 D	5.6	TSX 55 D	13.3	KA 24	ADB 27	2520	70	140	170
RUE 55 D L FE	RUE 55 D L OE	RWU 55 D L	7.5	TSX 55 D	13.3	KA 24	ADB 27	2520	70	140	210
RUE 65 D L FE	RUE 65 D L OE	RWU 65 D L	14.4	TSX 65 D	21.5	KA 26	ADB 29	2520	90	170	252.8

RUE..D FE has lubrication nipple to DIN 71 412-A M8 ± 1.

RUE..D OE has connector with union nut similar to DIN 3 871-A.

RUE 25 available on request.

RUE..U: Linear roller bearing and guideway assembly with guideway for fixing from below, available on request.

- 1) Suffix FE for grease lubrication, suffix OE for oil lubrication.
- 2) Closing plugs KA..TN are included with the delivery.
- 3) Maximum length L of single-piece guideways, longer guideways are supplied as multi-piece guideways and are marked accordingly.
- 4) Minimum covered length for sealing the lubrication connections.
- 5) Dimensions C₅ and C₆ are dependent on the guideway length L.
- 6) Position of the lubrication hole in the adjacent construction.
- 7) Maximum diameter of the lubrication hole in the adjacent construction.
- 8) Maximum length of fixing screw: H_B +3 mm.
- 9) If there is a possibility of settling, the fixing screws should be secured against rotation.

DIAMETERS AND TIGHTENING TORQUES FOR THREADS AND SCREWS ⁹⁾

PART NUMBER	K ₁ For screws to DIN 912-12.9		K ₂ For screws to DIN 912-12.9		K ₃ Through holes for screws to DIN 912-12.9		K ₆ Through holes for screws to DIN 7 984-8.8	
		Nm max.		Nm max.		Nm max.		Nm max.
RUE 35 D	M8	41	M10	41	M8	41	M8	24
RUE 35 D L	M8	41	M10	41	M8	41	M8	24
RUE 45 D	M12	140	M12	83	M10	83	M10	48
RUE 45 D L	M12	140	M12	83	M10	83	M10	48
RUE 55 D	M14	220	M14	140	M12	140	M12	83
RUE 55 D L	M14	220	M14	140	M12	140	M12	83
RUE 65 L	M16	340	M16	220	M14	220	M14	130



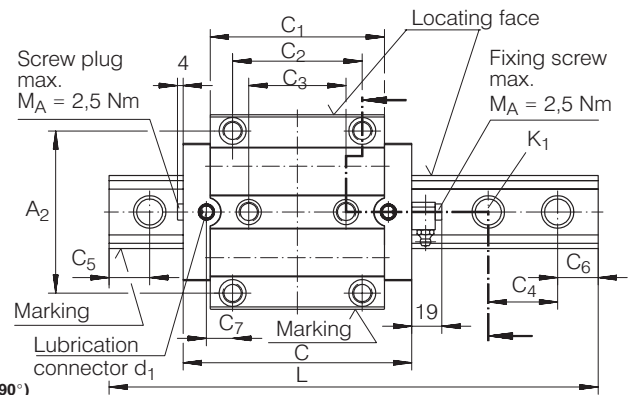
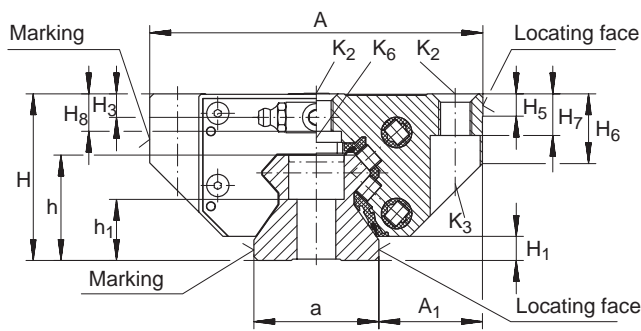

RUE..D

RUE..D
(View rotated through 90°)

A ₁	A ₂	a -0.005 -0.035	C ₁	C ₂	C ₃	C ₄	C ₅ ⁵⁾ min.	C ₅ ⁵⁾ max.	C ₆ ⁵⁾ min.	C ₆ ⁵⁾ max.	C ₇ ⁶⁾	d ₁ ⁷⁾ max.	H ₁	H ₃	H ₅	H ₆	H ₇	H ₈ ⁸⁾	h	h ₁
mm	mm	mm	mm	mm	mm	mm	mm	mm	mm	mm	mm	mm	mm	mm	mm	mm	mm	mm	mm	mm
33	82	34	91.4	62	52	40	20	31	20	31	14.3	6	6.5	6.6	8	20	12	11.1	30	19
33	82	34	114.4	62	52	40	20	31	20	31	25.8	6	6.5	6.6	8	20	12	11.1	30	19
37.5	100	45	107.5	80	60	52.5	20	41	20	41	16.2	6	8.5	8.5	8	26	15	13.5	38	22
37.5	100	45	141.7	80	60	52.5	20	41	20	41	33.3	6	8.5	8.5	8	26	15	13.5	38	22
43.5	116	53	130.8	95	70	60	20	47	20	47	21.2	6	11	10	12	31	18	15.5	45	28
43.5	116	53	170.5	95	70	60	20	47	20	47	41	6	11	10	12	31	18	15.5	45	28
53.5	142	63	207.6	110	82	75	20	61	20	61	49	6	11	10.2	15	39.2	23	23	53.8	30.3

PART NUMBER	LOAD CARRYING CAPACITY TABLE				
	BASIC LOAD RATINGS		MOMENT RATINGS		
	C kN	C ₀ kN	M _{0x} Nm	M _{0y} Nm	M _{0z} Nm
RUE 35 D	59	134	990	2140	1925
RUE 35 D L	70	169	1255	3370	3035
RUE 45 D	92	205	1805	3870	3485
RUE 45 D L	115	275	2410	6770	6095
RUE 55 D	135	305	3130	7035	6335
RUE 55 D L	167	405	4120	12010	10815
RUE 65 D L	270	640	7600	24000	21500

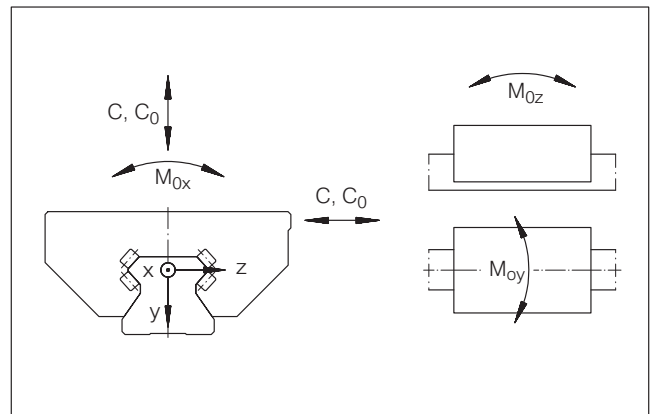

Load directions



Linear Recirculating Roller Bearing And Guideway Assemblies

RUE..D H, RUE..D HL SERIES

For details on part numbers, descriptive suffixes and various technical references, please refer to front of this section.

For engineering or technical information contact your local sales representative or call Distributor Sales (800)523-6572 or Linear Sales (800)462-3399.

Linear roller bearing and guideway assembly Grease Lubrication PART NUMBER	Linear roller bearing and guideway assembly Oil Lubrication PART NUMBER	CARRIAGE ¹⁾ PART NUMBER	CARRIAGE MASS kg	GUIDEWAY PART NUMBER	GUIDEWAY MASS kg/m	GUIDEWAY Closing Plugs ²⁾	COVERING STRIP	L ³⁾ mm	H mm	A mm	C ⁴⁾ mm
RUE 35 D H FE	RUE 35 D H OE	RWU 35 D H	1.7	TSX 35 D	5.9	KA 15	ADB 18	2960	55	70	120
RUE 35 D HL FE	RUE 35 D HL OE	RWU 35 D HL	2.4	TSX 35 D	5.9	KA 15	ADB 18	2960	55	70	143
RUE 45 D H FE	RUE 45 D H OE	RWU 45 D H	3.1	TSX 45 D	9.4	KA 20	ADB 23	2940	70	86	141
RUE 45 D HL FE	RUE 45 D HL OE	RWU 45 D HL	4.0	TSX 45 D	9.4	KA 20	ADB 23	2940	70	86	175
RUE 55 D H FE	RUE 55 D H OE	RWU 55 D H	5.3	TSX 55 D	13.3	KA 24	ADB 24	2520	80	100	170
RUE 55 D HL FE	RUE 55 D HL OE	RWU 55 D HL	6.7	TSX 55 D	13.3	KA 24	ADB 24	2520	80	100	210
RUE 65 D HL FE	RUE 65 D HL OE	RWU 65 D HL	13.6	TSX 65 D	21.5	KA 26	ADB 26	2520	100	126	252.8

RUE..D H FE has lubrication nipple to DIN 71 412-A M8 ± 1.

RUE..D H OE has connector with union nut similar to DIN 3 871-A.

RUE..DU: Linear roller bearing and guideway assembly with guideway for fixing from below, available on request.

- 1) Suffix FE for grease lubrication, suffix OE for oil lubrication.
- 2) Closing plugs KA..TN are included with the delivery.
- 3) Maximum length L of single-piece guideways, longer guideways are supplied as multi-piece guideways and are marked accordingly.
- 4) Minimum covered length for sealing the lubrication connections.
- 5) Dimensions C₅ and C₆ are dependent on the guideway length L.
- 6) Position of the lubrication hole in the adjacent construction.
- 7) Maximum diameter of the lubrication hole in the adjacent construction.
- 8) If there is a possibility of settling, the fixing screws should be secured against rotation.

DIAMETERS AND TIGHTENING TORQUES FOR THREADS AND SCREWS ⁸⁾				
PART NUMBER	K ₁ For screws to DIN 912-12.9		K ₂ For screws to DIN 912-12.9	
		Nm max.		Nm max.
RUE 35 D H	M8	41	M8	41
RUE 35 D HL	M8	41	M8	41
RUE 45 D H	M12	140	M10	83
RUE 45 D HL	M12	140	M10	83
RUE 55 D H	M14	220	M12	140
RUE 55 D HL	M14	220	M12	140
RUE 65 D HL	M16	340	M14	220

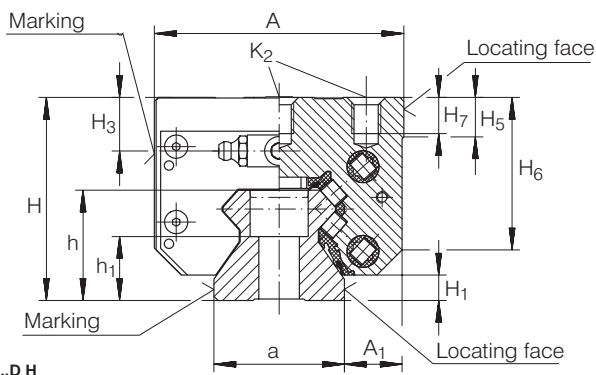

RUE..D H

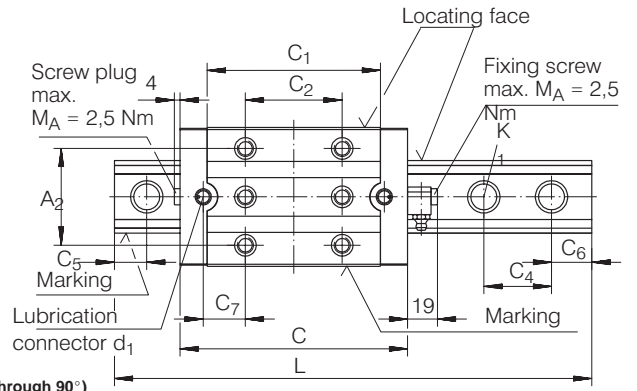

RUE..D H
(View rotated through 90°)

A ₁	A ₂	a -0.005 -0.035	C ₁	C ₂	C ₄	C ₅ ⁵⁾ min.	C ₅ ⁵⁾ max.	C ₆ ⁵⁾ min.	C ₆ ⁵⁾ max.	C ₇ ⁶⁾	d ₁ ⁷⁾ max.	H ₁	H ₃	H ₅	H ₆	H ₇	h	h ₁
mm	mm	mm	mm	mm	mm	mm	mm	mm	mm	mm	mm	mm	mm	mm	mm	mm	mm	mm
18	50	34	91.4	50	40	20	31	20	31	20.3	6	6.5	13.6	10.8	41	10	30	19
18	50	34	114.4	72	40	20	31	20	31	20.8	6	6.5	13.6	10.8	41	10	30	19
20.5	60	45	107.5	60	52.5	20	41	20	41	26.2	6	8.5	18.5	13.7	52	12.5	38	22
20.5	60	45	141.7	80	52.5	20	41	20	41	33.3	6	8.5	18.5	13.7	52	12.5	38	22
23.5	75	53	130.8	75	60	20	47	20	47	31.2	6	11	20	16	61	15	45	28
23.5	75	53	170.5	95	60	20	47	20	47	41	6	11	20	16	61	15	45	28
31.5	76	63	207.6	120	75	20	61	20	61	43.8	6	11	20.2	15	71.2	20	53.8	30.3

LOAD CARRYING CAPACITY TABLE					
PART NUMBER	BASIC LOAD RATINGS		MOMENT RATINGS		
	C kN	C ₀ kN	M _{0x} Nm	M _{0y} Nm	M _{0z} Nm
RUE 35 D H	59	134	990	2140	1925
RUE 35 D HL	70	169	1255	3370	3035
RUE 45 D H	92	205	1805	3870	3485
RUE 45 D HL	115	275	2410	6770	6095
RUE 55 D H	135	305	3130	7035	6335
RUE 55 D HL	167	405	4120	12010	10815
RUE 65 D HL	270	640	7600	24000	21500

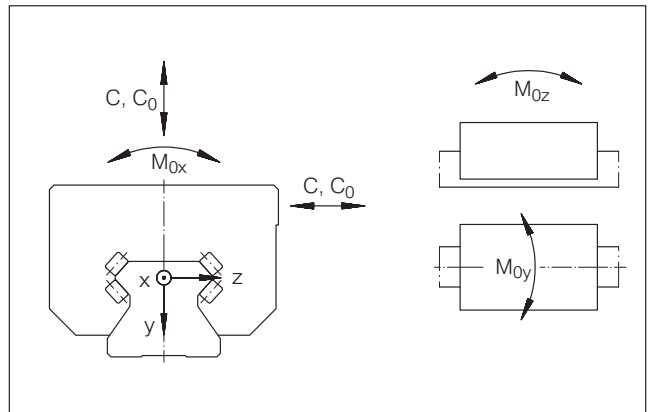

Load directions



Locking Element RUKS..D SERIES

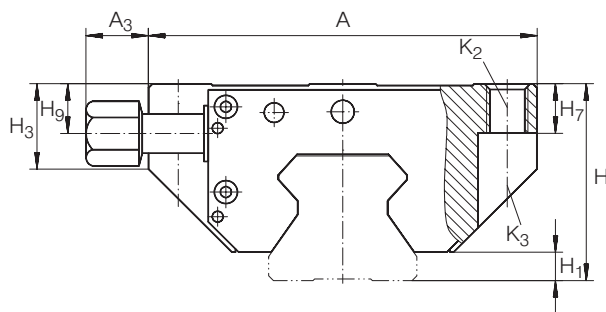

For details on part numbers, descriptive suffixes and various technical references, please refer to front of this section.

For engineering or technical information contact your local sales representative or call Distributor Sales (800)523-6572 or Linear Sales (800)462-3399.

PART NUMBER	MASS kg	A mm	H mm	C mm	A ₂ mm	A ₃ mm	C ₁ mm	C ₂ mm	C ₃ mm	C ₇ mm
RUKS 35 D S	2.8	98	48	135	82	24.5	113	62	52	32
RUKS 35 D O	2.8	98	48	135	82	–	113	62	52	32
RUKS 35 DH S	2.8	68	55	135	50	34.5	113	50	–	38
RUKS 35 DH O	2.8	68	55	135	50	–	113	50	–	38
RUKS 45 D S	4.5	118	60	156	100	22	134	80	60	33.5
RUKS 45 D O	4.5	118	60	156	100	–	134	80	60	33.5
RUKS 45 DH S	4.5	84	70	156	60	39	134	60	–	43.5
RUKS 45 DH O	4.5	84	70	156	60	–	134	60	–	43.5
RUKS 55 D S	7.6	138	70	185	116	18.5	163	95	70	40.5
RUKS 55 D O	7.6	138	70	185	116	–	163	95	70	40.5
RUKS 55 DH S	7.6	98	80	185	75	38.5	163	75	–	50.5
RUKS 55 DH O	7.6	98	80	185	75	–	163	75	–	50.5

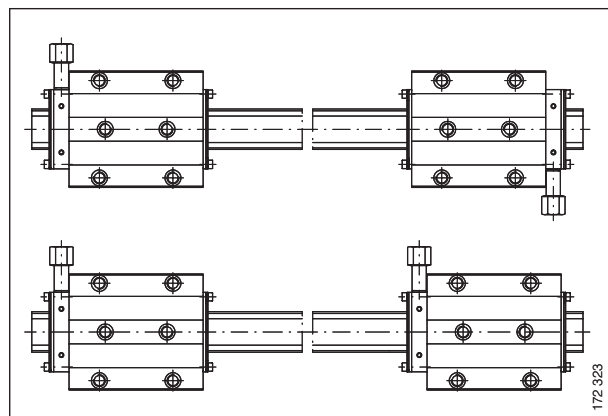

Position of oil connector, possible combinations

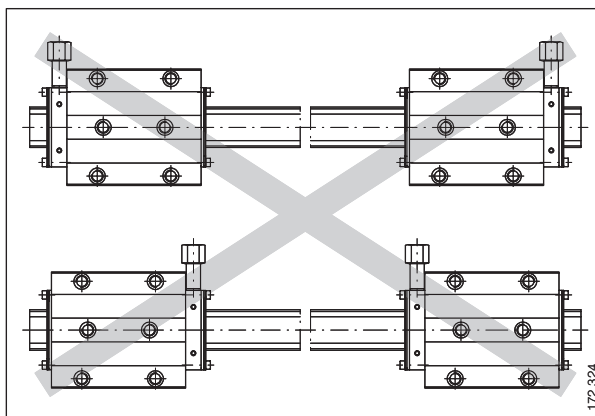

Position of oil connector, impermissible combinations

Locking Element RUKS..D SERIES

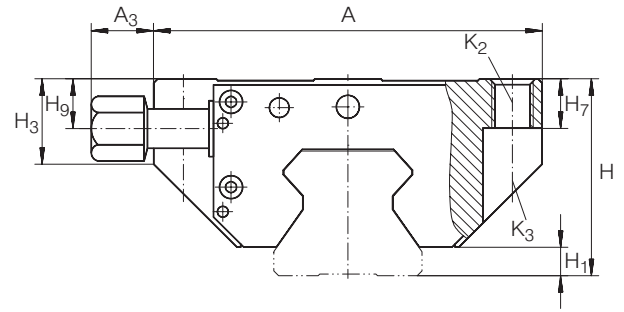

For details on part numbers, descriptive suffixes and various technical references, please refer to front of this section.

For engineering or technical information contact your local sales representative or call Distributor Sales (800)523-6572 or Linear Sales (800)462-3399.

d ₁ max. mm	H ₁ mm	H ₃ mm	H ₇ mm	H ₉ mm	Suitable for guideway	K ₂ For screws to DIN 912-12.9	K ₂ max. Nm	K ₃ Through hole for screws to DIN 912-12.9	K ₃ max. Nm	PART NUMBER
6	6.5	21	12	13.2	TSX 35 D	M10	41	M8	41	RUKS 35 D S
6	6.5	21	12	—	TSX 35 D	M10	41	M8	41	RUKS 35 D O
6	6.5	42	10	20.2	TSX 35 D	M8	41	—	—	RUKS 35 DH S
6	6.5	42	10	—	TSX 35 D	M8	41	—	—	RUKS 35 DH O
6	8.5	27	15	15.6	TSX 45 D	M12	83	M10	83	RUKS 45 D S
6	8.5	27	15	—	TSX 45 D	M12	83	M10	83	RUKS 45 D O
6	8.5	53	10	25.6	TSX 45 D	M10	83	—	—	RUKS 45 DH S
6	8.5	53	10	—	TSX 45 D	M10	83	—	—	RUKS 45 DH O
6	11	32	18	18.8	TSX 55 D	M14	140	M12	140	RUKS 55 D S
6	11	32	18	—	TSX 55 D	M14	140	M12	140	RUKS 55 D O
6	11	62	15	28.8	TSX 55 D	M12	140	—	—	RUKS 55 DH S
6	11	62	15	—	TSX 55 D	M12	140	—	—	RUKS 55 DH O

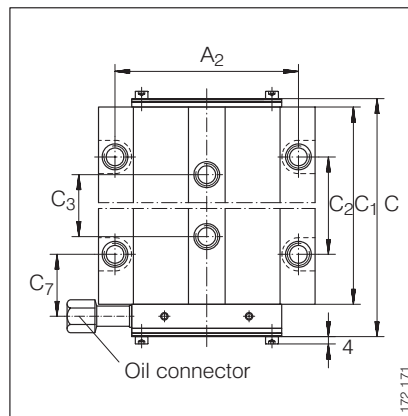

RUKS..D S

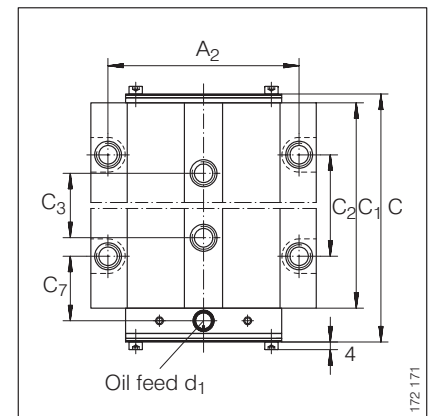

RUKS..D O



Sheet Steel Wiper APLU SERIES

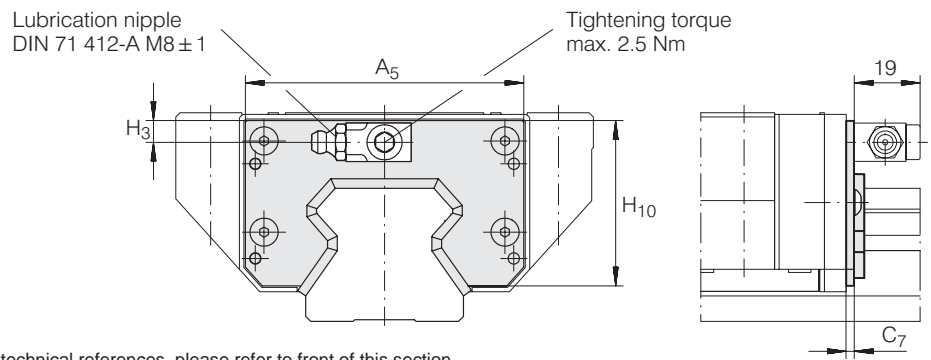

For details on part numbers, descriptive suffixes and various technical references, please refer to front of this section.

For engineering or technical information contact your local sales representative or call Distributor Sales (800)523-6572 or Linear Sales (800)462-3399.

PART NUMBER	MASS g	A ₅ mm	H ₃ mm	H ₁₀ mm	C ₇ mm	Suitable for linear recirculating roller bearing and guideway assembly	
APLU 35 D	60	66.7	6.6	39.7	6.5	RUE 35 D	RUE 35 D L
			13.6			RUE 35 D H	RUE 35 D HL
APLU 45 D	75	81.5	8.5	49.3	6.5	RUE 45 D	RUE 45 D L
			18.5			RUE 45 D H	RUE 45 D HL
APLU 55 D	90	94.8	10	56.8	7.5	RUE 55 D	RUE 55 D L
			20			RUE 55 D H	RUE 55 D HL
APLU 65 D	105	120.3	10.2	76.2	6.3	-	RUE 65 D L
			20.2			-	RUE 65 D HL

Lubrication Adapter Plate BPLU SERIES

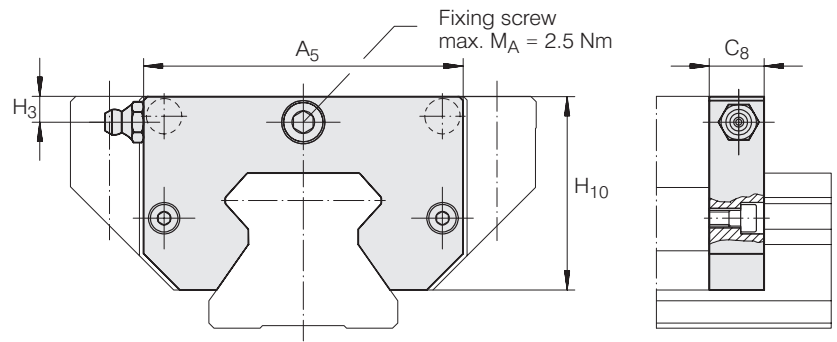

For details on part numbers, descriptive suffixes and various technical references, please refer to front of this section.

For engineering or technical information contact your local sales representative or call Distributor Sales (800)523-6572 or Linear Sales (800)462-3399.

PART NUMBER GREASE LUBRICATION	PART NUMBER OIL LUBRICATION	MASS g	A ₅ mm	H ₃ mm	H ₁₀ mm	C ₈ mm	Suitable for linear recirculating roller bearing and guideway assembly	
BPLU 35 D FE	BPLU 35 D OE	95	66.7	7.5	39.7	14	RUE 35 D	RUE 35 D L
				11.5			RUE 35 D H	RUE 35 D HL
BPLU 45 D FE	BPLU 45 D OE	120	81.5	8	49.3	14	RUE 45 D	RUE 45 D L
				15			RUE 45 D H	RUE 45 D HL
BPLU 55 D FE	BPLU 55 D OE	150	94.8	10	56.8	14	RUE 55 D	RUE 55 D L
				20			RUE 55 D H	RUE 55 D HL
BPLU 65 D FE	BPLU 65 D OE	190	120.8	10.2	76.2	14	–	RUE 65 D L
				20.2			–	RUE 65 D HL

BPLU..D FE has lubrication nipple to DIN 71 412-A M8 ± 1.

BPLU..D OE has connector with union nut similar to DIN 3 871-A.

The lubrication nipple or connector can be replaced by a screw plug M8 ± 1.

In series RUE..D H and RUE..D HL, the lubrication nipple protrudes about 9 mm from the side of the carriage.

Minimal Quantity Lubricant Metering Unit SMDE SERIES

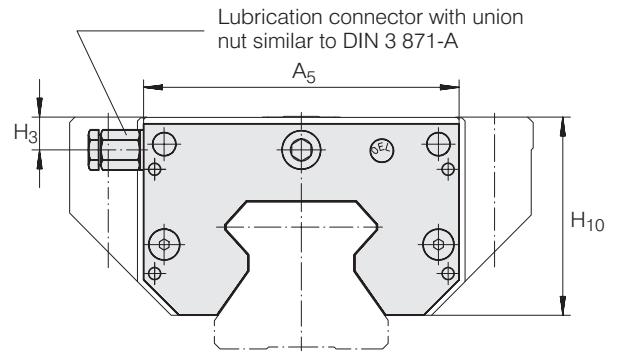

For details on part numbers, descriptive suffixes and various technical references, please refer to front of this section.

For engineering or technical information contact your local sales representative or call Distributor Sales (800)523-6572 or Linear Sales (800)462-3399.

PART NUMBER	MASS g	A ₅ mm	H ₃ mm	H ₁₀ mm	C ₇ with RUE..D RUE..D H mm	C ₇ with RUE..L RUE..D HL mm	C ₈ mm	d ₁ max mm	Suitable for linear recirculating roller bearing and guideway assembly	
SMDE 35 D S	170	66.9	6.6	41.1	44	55.5	25	—	RUE 35 D	RUE 35 D L
SMDE 35 D O	170	66.9	—	41.1	37.2	48.7	25	6	RUE 35 D	RUE 35 D L
SMDE 35 D HS	200	66.9	13.6	48.1	50	50.5	25	—	RUE 35 D H	RUE 35 D HL
SMDE 35 D HO	200	66.9	—	48.1	43.2	43.7	25	6	RUE 35 D H	RUE 35 D HL
SMDE 45 D S	200	81.7	8.5	51.2	44.8	61.8	25	—	RUE 45 D	RUE 45 D L
SMDE 45 D O	200	81.7	—	51.2	38	55	25	6	RUE 45 D	RUE 45 D L
SMDE 45 D HS	260	81.7	18.5	61.2	54.8	61.8	25	—	RUE 45 D H	RUE 45 D HL
SMDE 45 D HO	260	81.7	—	61.2	48	55	25	6	RUE 45 D H	RUE 45 D HL
SMDE 55 D S	240	95	10	58.9	51.5	71.5	25	—	RUE 55 D	RUE 55 D L
SMDE 55 D O	240	95	—	58.9	44.7	64.7	25	6	RUE 55 D	RUE 55 D L
SMDE 55 D HS	340	95	20	68.9	61.5	71.5	25	—	RUE 55 D H	RUE 55 D HL
SMDE 55 D HO	340	95	—	68.9	54.7	64.7	25	6	RUE 55 D H	RUE 55 D HL
SMDE 65 D S	500	121	10.2	78.5	—	85	25	—	—	RUE 65 D L
SMDE 65 D O	500	121	10.2	78.5	—	78.2	25	6	—	RUE 65 D L
SMDE 65 D HS	500	121	20.2	88.5	—	80	25	—	—	RUE 65 D HL
SMDE 65 D HO	500	121	20.2	88.5	—	73.2	25	6	—	RUE 65 D HL

In series RUE..D H and RUE..D HL, the lubrication connector protrudes about 9 mm from the side of the carriage.

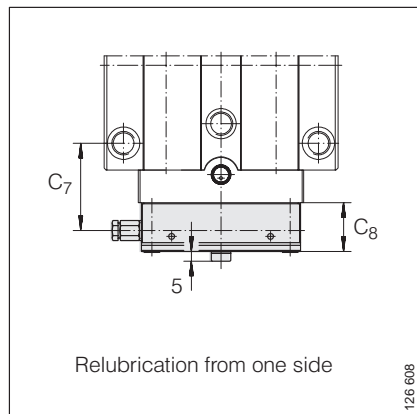

SMDE..D S

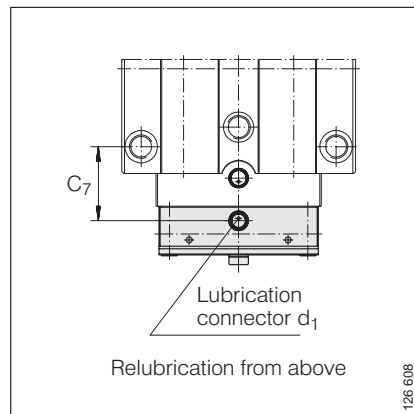

SMDE..D O

Damping Carriage RUDS SERIES

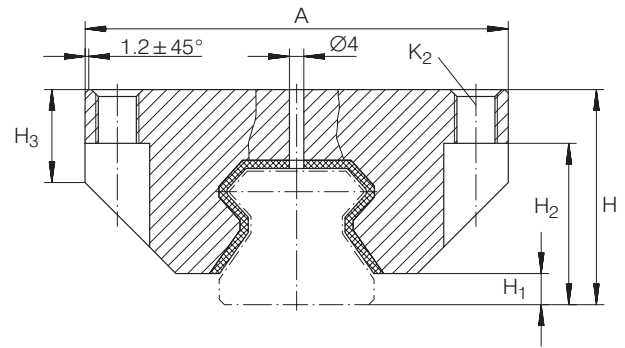

For details on part numbers, descriptive suffixes and various technical references, please refer to front of this section.

For engineering or technical information contact your local sales representative or call Distributor Sales (800)523-6572 or Linear Sales (800)462-3399.

PART NUMBER	MASS kg/100 mm	A mm	H mm	H ₁ mm	H ₂ mm	H ₃ mm	A ₁ mm	C ₁ mm	C ₂ mm	C ₃ mm	K ₂ ²⁾	3)	Suitable for linear recirculating roller bearing and guideway assembly	
RUDS 35 D	2.1	98	48	6.5	36	21	82	37.5	75	75	M10	M8	RUE 35 D	RUE 35 D L
RUDS 35 D H	1.8	68	55	6.5	–	42	50	37.5	75	75	M8	–	RUE 35 D H	RUE 35 D HL
RUDS 45 D	3.6	118	60	8.5	45	27	100	37.5	75	75	M12	M10	RUE 45 D	RUE 45 D L
RUDS 45 D H	3	84	70	8.5	–	53	60	37.5	75	75	M10	–	RUE 45 D H	RUE 45 D HL
RUDS 55 D	4.4	138	70	11	52	32	116	37.5	75	75	M14	M12	RUE 55 D	RUE 55 D L
RUDS 55 D H	3.7	98	80	11	–	62	75	37.5	75	75	M12	–	RUE 55 D H	RUE 55 D HL
RUDS 65 D	5	168	90	11	67	40.2	142	37.5	75	75	M16	M14	–	RUE 65 D L
RUDS 65 D H	4.6	124	100	11	–	72.2	76	37.5	75	75	M16	–	–	RUE 65 D HL

1) Standard lengths:

C = 150 mm, not RUDS 65

C = 225 mm, not RUDS 65

C = 300 mm,

2) For screws to DIN 912-12.9,

thread length for RUDS..D H: at least $1.25 \cdot K_2$

3) K₂ as through hole for screws to DIN 912-12.9,

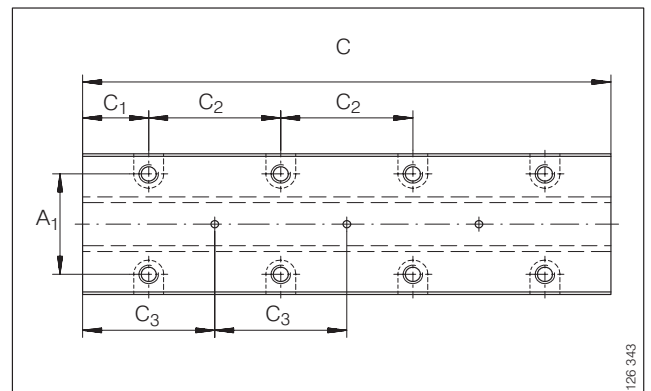

RUDS (View rotated through 90°)

128 343



Linear Recirculating Ball Bearing And Guideway Assemblies

KUSE SERIES

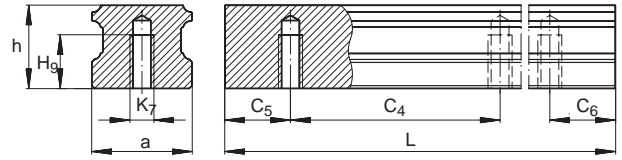

Guideway TKSD..U for mounting from below, suffix U (example: KUSE..U)

For details on part numbers, descriptive suffixes and various technical references, please refer to front of this section.

For engineering or technical information contact your local sales representative or call Distributor Sales (800)523-6572 or Linear Sales (800)462-3399.

DIMENSION TABLE - Dimensions in mm														
UNIT	CARRIAGE		GUIDEWAY				DIMENSIONS				MOUNTING DIMENSIONS			
PART NUMBER	PART NUMBER	MASS	PART NUMBER	MASS	CLOSING PLUGS	COVERING STRIP	L ¹⁾	H	A	C ²⁾	A ₁	A ₂	a	a ₃
		kg		kg/m									-0.005 -0.03	
KUSE 20	KWSE 20	0.43	TKSD 20	2.3	KA 10 TN	ADB 13	1,980	30	63	71	21.5	53	20	5
KUSE 25	KWSE 25	0.6	TKSD 25	3.1	KA 11 TN	ADB 13	1,980	36	70	81.5	23.5	57	23	6.5
KUSE 30	KWSE 30	1.2	TKSD 30	4.4	KA 15 TN	ADB 18	2,000	42	90	91.2	31	72	28	9
KUSE 35	KWSE 35	1.5	TKSD 35	6.5	KA 15 TN	ADB 18	2,960	48	100	106.7	33	82	34	9
KUSE 45	KWSE 45	3.15	TKSD 45	11.3	KA 20 TN	ADB 23	2,940	60	120	136.5	37.5	100	45	10
KUSE 55	KWSE 55	4.9	TKSD 55	15.7	KA 24 TN	ADB 23	2,520	70	140	158	43.5	116	53	12

- 1) Maximum length L of single piece guideway; longer guideways are supplied as multi-piece guideways and are marked accordingly.
- 2) Minimum covered length for sealing the lubrication connections.
- 3) Dimensions C₅ and C₆ are dependent on the guideway length L.
- 4) Position of the lubrication hole in the adjacent construction.
- 5) Maximum diameter of the lubrication hole in the adjacent construction.
- 6) When mounting from above: maximum length of fixing screw for the central fixing holes H₈ +3 mm.
- 7) If there is a possibility of settling, the fixing screws should be secured against rotation.

DIAMETERS AND TIGHTENING TORQUES FOR THREADS AND SCREWS ⁷⁾										
PART NUMBER	K ₁ for screws to DIN 912-12.9		K ₂ for screws to DIN 912-12.9		K ₃ Through holes for screws to DIN 912-12.9		K ₆ Through holes for screws to DIN 7 984-8.8		K ₇ for screws to DIN 912-12.9	
		Nm max.		Nm max.		Nm max.		Nm max.		Nm max.
KUSE 20	M5	10	M6	10	M5	10	M5	5.8	M6	17
KUSE 25	M6	17	M8	24	M6	17	M6	10	M6	17
KUSE 30	M8	41	M10	41	M8	41	M8	24	M8	41
KUSE 35	M8	41	M10	41	M8	41	M8	24	M8	41
KUSE 45	M12	140	M12	83	M10	83	M10	48	M12	140
KUSE 55	M14	220	M14	140	M12	140	M12	83	M14	220

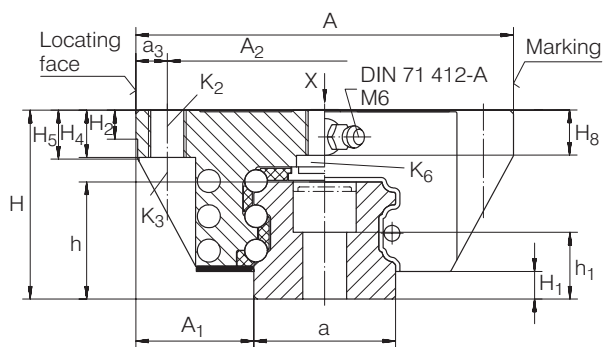

KUSE

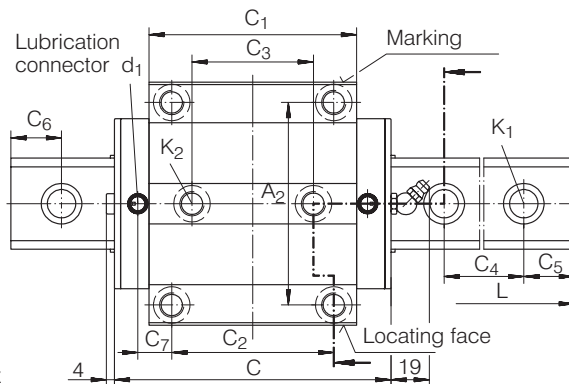

KUSE, plan view X
(rotated through 90°)

C ₁	C ₂	C ₃	C ₄	C ₅ ³⁾		C ₆ ³⁾		C ₇ ⁴⁾	d ₁ ⁵⁾	H ₁	H ₂	H ₄	H ₅	H ₈ ⁶⁾	H ₉	h	h ₁
				min.	max.	min.	max.										
52	40	35	60	20	53	20	53	9.8	3	4.6	5	10	10.4	7.2	10	18	10.3
60.5	45	40	60	20	53	20	53	12.8	3	5.2	5	10	9.5	9.5	12	21.7	12.7
67.2	52	44	80	20	71	20	71	12.6	4.5	5.5	6	12	11.9	10	15	25	14
77.7	62	52	80	20	71	20	71	11.7	4.5	6.6	6.5	13	13	12	15	29.7	18.7
102.5	80	60	105	20	94	20	94	15.8	6	8.6	9	15	15.5	15	20	37.2	21.2
117.7	95	70	120	20	107	20	107	19.2	6	10.8	12	18	18.6	17	22	44	27

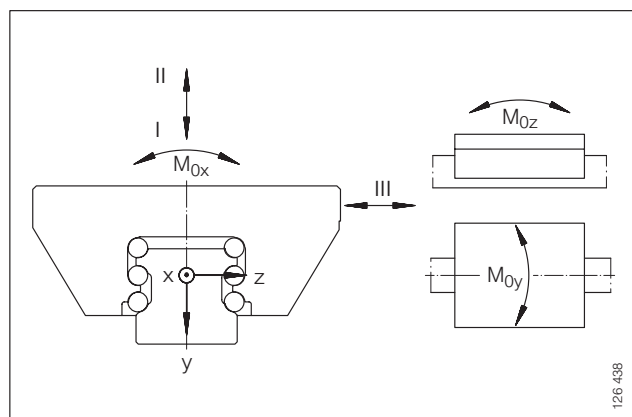

Load directions

PART NUMBER	LOAD CARRYING CAPACITY TABLE								
	BASIC LOAD RATINGS						MOMENT RATINGS		
	LOAD DIRECTION I: COMPRESSIVE LOAD		LOAD DIRECTION II: TENSILE LOAD		LOAD DIRECTION III: LATERAL LOAD		M _{0x}	M _{0y}	M _{0z}
C kN	C ₀ kN	C kN	C ₀ kN	C kN	C ₀ kN	Nm	Nm	Nm	
KUSE 20	22	52	17.5	33.5	16.3	36	358	333	303
KUSE 25	28	67	22.9	43	21.3	46	535	486	442
KUSE 30	40	80	33	60	30.5	64	896	762	694
KUSE 35	55	102	45	79	42	85	1,454	1,173	1,069
KUSE 45	80	174	65	117	59	126	2,794	2,237	2,037
KUSE 55	102	230	81	147	75	157	4,114	3,141	2,861



Linear Recirculating Ball Bearing And Guideway Assemblies

KUSE..L SERIES

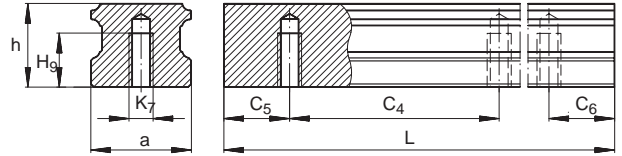

Guideway TKSD..U for mounting from below, suffix U (example: KUSE..U)

For details on part numbers, descriptive suffixes and various technical references, please refer to front of this section.

For engineering or technical information contact your local sales representative or call Distributor Sales (800)523-6572 or Linear Sales (800)462-3399.

DIMENSION TABLE - Dimensions in mm														
UNIT	Carriage		GUIDEWAY				DIMENSIONS				MOUNTING DIMENSIONS			
PART NUMBER	PART NUMBER	MASS	PART NUMBER	MASS	CLOSING PLUGS	COVERING STRIP	L ¹⁾	H	A	C ²⁾	A ₁	A ₂	a	a ₃
		kg		kg/m									-0.005 -0.03	
KUSE 20 L	KWSE 20 L	0.6	TKSD 20	2.3	KA 10 TN	ADB 13	1,980	30	63	90.8	21.5	53	20	5
KUSE 25 L	KWSE 25 L	0.82	TKSD 25	3.1	KA 11 TN	ADB 13	1,980	36	70	104	23.5	57	23	6.5
KUSE 30 L	KWSE 30 L	1.6	TKSD 30	4.4	KA 15 TN	ADB 18	2,000	42	90	118.7	31	72	28	9
KUSE 35 L	KWSE 35 L	2.1	TKSD 35	6.5	KA 15 TN	ADB 18	2,960	48	100	138.4	33	82	34	9
KUSE 45 L	KWSE 45 L	4.2	TKSD 45	11.3	KA 20 TN	ADB 23	2,940	60	120	172.2	37.5	100	45	10
KUSE 55 L	KWSE 55 L	6.6	TKSD 55	15.7	KA 24 TN	ADB 23	2,520	70	140	198	43.5	116	53	12

- 1) Maximum length L of single piece guideway; longer guideways are supplied as multi-piece guideways and are marked accordingly.
- 2) Minimum covered length for sealing the lubrication connections.
- 3) Dimensions C₅ and C₆ are dependent on the guideway length L.
- 4) Position of the lubrication hole in the adjacent construction.
- 5) Maximum diameter of the lubrication hole in the adjacent construction.
- 6) When mounting from above: maximum length of fixing screw for the central fixing holes H₈ +3 mm.
- 7) If there is a possibility of settling, the fixing screws should be secured against rotation.

DIAMETERS AND TIGHTENING TORQUES FOR THREADS AND SCREWS ⁷⁾										
PART NUMBER	K ₁ for screws to DIN 912-12.9		K ₂ for screws to DIN 912-12.9		K ₃ Through holes for screws to DIN 912-12.9		K ₆ Through holes for screws to DIN 7984-8.8		K ₇ for screws to DIN 912-12.9	
		Nm max.		Nm max.		Nm max.		Nm max.		Nm max.
KUSE 20 L	M5	10	M6	10	M5	10	M5	5.8	M6	17
KUSE 25 L	M6	17	M8	24	M6	17	M6	10	M6	17
KUSE 30 L	M8	41	M10	41	M8	41	M8	24	M8	41
KUSE 35 L	M8	41	M10	41	M8	41	M8	24	M8	41
KUSE 45 L	M12	140	M12	83	M10	83	M10	48	M12	140
KUSE 55 L	M14	220	M14	140	M12	140	M12	83	M14	220



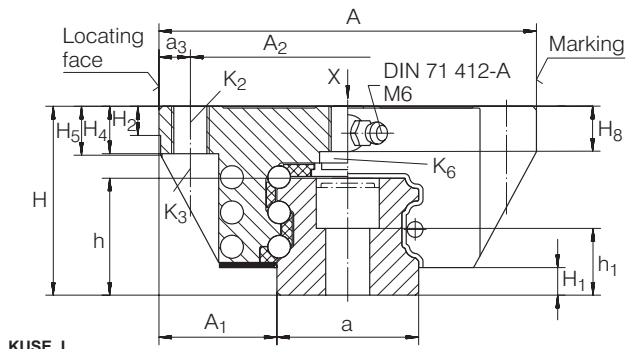

KUSE..L

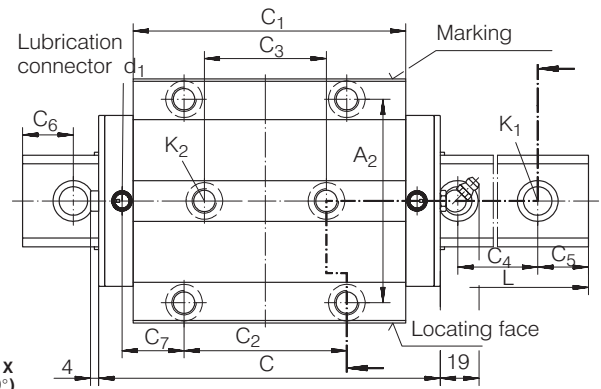

KUSE..L, plan view X
(rotated through 90°)

C ₁	C ₂	C ₃	C ₄	C ₅ ³⁾		C ₆ ³⁾		C ₇ ⁴⁾	d ₁ ⁵⁾	H ₁	H ₂	H ₄	H ₅	H ₈ ⁶⁾	H ₉	h	h ₁
				min.	max.	min.	max.										
71.8	40	35	60	20	53	20	53	19.7	3	4.6	5	10	10.4	7.2	10	18	10.3
83	45	40	60	20	53	20	53	24	3	5.2	5	10	9.5	9.5	12	21.7	12.7
94.7	52	44	80	20	71	20	71	26.3	4.5	5.5	6	12	11.9	10	15	25	14
109.4	62	52	80	20	71	20	71	27.5	4.5	6.6	6.5	13	13	12	15	29.7	18.7
138.2	80	60	105	20	94	20	94	33.6	6	8.6	9	15	15.5	15	20	37.2	21.2
157.7	95	70	120	20	107	20	107	39.2	6	10.8	12	18	18.6	17	22	44	27

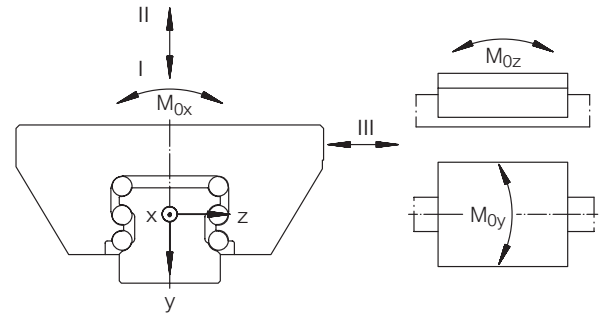

Load directions

126 438

PART NUMBER	LOAD CARRYING CAPACITY TABLE								
	BASIC LOAD RATINGS						MOMENT RATINGS		
	LOAD DIRECTION I: COMPRESSIVE LOAD		LOAD DIRECTION II: TENSILE LOAD		LOAD DIRECTION III: LATERAL LOAD		M _{0x} Nm	M _{0y} Nm	M _{0z} Nm
C kN	C ₀ kN	C kN	C ₀ kN	C kN	C ₀ kN				
KUSE 20 L	28	72	22.2	46.5	18.9	50	494	619	564.6
KUSE 25 L	35.3	93.7	28.9	59.8	24.7	64	736	903	823
KUSE 30 L	51	113	42.4	84.3	36.5	90	1,265	1,478	1,346
KUSE 35 L	70	145	57.3	112.4	49.5	120	2,054	2,275	2,072
KUSE 45 L	98	236	79.3	159	69	170	3,792	4,011	3,654
KUSE 55 L	125.4	312	100.6	199.4	87	214	5,584	5,633	5,132



Linear Recirculating Ball Bearing And Guideway Assemblies

KUSE..H SERIES

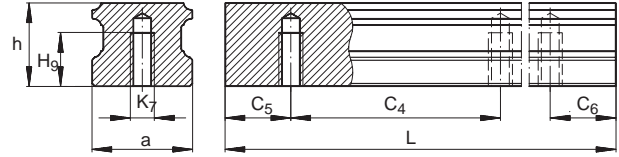

Guideway TKSD..U for mounting from below, suffix U (example: KUSE..U)

For details on part numbers, descriptive suffixes and various technical references, please refer to front of this section.

For engineering or technical information contact your local sales representative or call Distributor Sales (800)523-6572 or Linear Sales (800)462-3399.

DIMENSION TABLE - Dimensions in mm														
UNIT	CARRIAGE		GUIDEWAY				DIMENSIONS				MOUNTING DIMENSIONS			
PART NUMBER	PART NUMBER	MASS	PART NUMBER	Mass	CLOSING PLUGS	COVERING STRIP	L ¹⁾	H	A	C ²⁾	A ₁	A ₂	a	a ₃
		kg		kg/m									-0.005 -0.03	
KUSE 20 H	KWSE 20 H	0.32	TKSD 20	2.3	KA 10 TN	ADB 13	1,980	30	44	71	12	32	20	6
KUSE 25 H	KWSE 25 H	0.5	TKSD 25	3.1	KA 11 TN	ADB 13	1,980	40	48	81.5	12.5	35	23	6.5
KUSE 30 H	KWSE 30 H	0.9	TKSD 30	4.4	KA 15 TN	ADB 18	2,000	45	60	91.2	16	40	28	10
KUSE 35 H	KWSE 35 H	1.3	TKSD 35	6.5	KA 15 TN	ADB 18	2,960	55	70	106.7	18	50	34	10
KUSE 45 H	KWSE 45 H	2.75	TKSD 45	11.3	KA 20 TN	ADB 23	2,940	70	86	136.5	20.5	60	45	13
KUSE 55 H	KWSE 55 H	4.5	TKSD 55	15.7	KA 24 TN	ADB 23	2,520	80	100	158	23.5	75	53	12.5

- 1) Maximum length L of single piece guideway; longer guideways are supplied as multi-piece guideways and are marked accordingly.
- 2) Minimum covered length for sealing the lubrication connections.
- 3) Dimensions C₅ and C₆ are dependent on the guideway length L.
- 4) Position of the lubrication hole in the adjacent construction.
- 5) Maximum diameter of the lubrication hole in the adjacent construction.
- 6) If there is a possibility of settling, the fixing screws should be secured against rotation.

DIAMETERS AND TIGHTENING TORQUES FOR THREADS AND SCREWS ⁶⁾						
PART NUMBER	K ₁ for screws to DIN 912-12.9		K ₂ for screws to DIN 912-12.9		K ₇ for screws to DIN 912-12.9	
		Nm max.		Nm max.		Nm max.
KUSE 20 H	M5	10	M5	10	M6	17
KUSE 25 H	M6	17	M6	17	M6	17
KUSE 30 H	M8	41	M8	41	M8	41
KUSE 35 H	M8	41	M8	41	M8	41
KUSE 45 H	M12	140	M10	83	M12	140
KUSE 55 H	M14	220	M12	140	M14	220



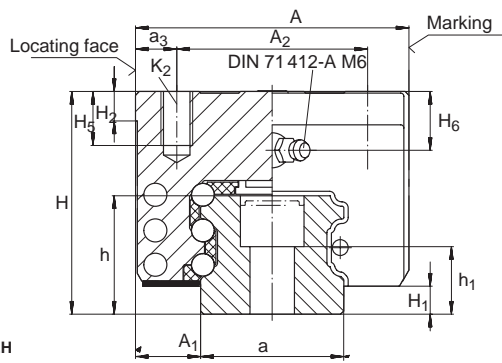

KUSE..H

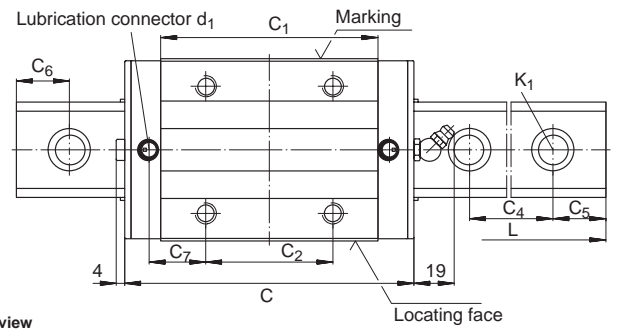

KUSE..H, plan view
(rotated through 90°)

C ₁	C ₂	C ₄	C ₅ ³⁾		C ₆ ³⁾		C ₇ ⁴⁾	d ₁ ⁵⁾ max.	H ₁	H ₂	H ₅	H ₆	H ₉	h	h ₁
			min.	max.	min.	max.									
52	36	60	20	53	20	53	11.8	3	4.6	5	6.25	5.8	10	18	10.3
60.5	35	60	20	53	20	53	17.8	3	5.2	5	10	10	12	21.7	12.7
67.2	40	80	20	71	20	71	18.6	4.5	5.5	6	11	9.5	15	25	14
77.7	50	80	20	71	20	71	17.7	4.5	6.6	6.5	14	14.2	15	29.7	18.7
102.5	60	105	20	94	20	94	25.8	6	8.6	9	17	18.5	20	37.2	21.2
117.7	75	120	20	107	20	107	29.2	6	10.8	12	19	20	22	44	27

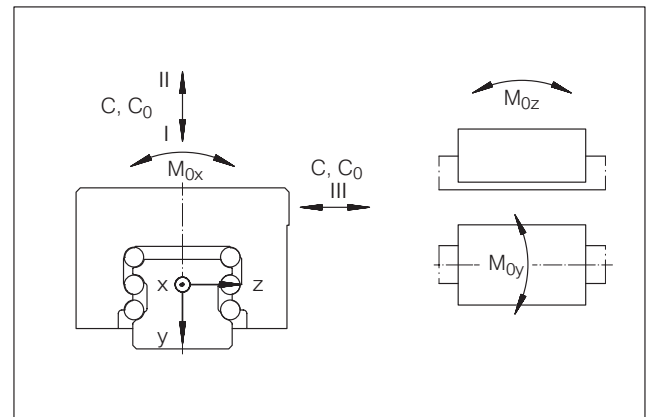

Load directions

PART NUMBER	LOAD CARRYING CAPACITY TABLE								
	BASIC LOAD RATINGS						MOMENT RATINGS		
	LOAD DIRECTION I: COMPRESSIVE LOAD		LOAD DIRECTION II: TENSILE LOAD		LOAD DIRECTION III: LATERAL LOAD		M _{0x} Nm	M _{0y} Nm	M _{0z} Nm
C kN	C ₀ kN	C kN	C ₀ kN	C kN	C ₀ kN				
KUSE 20 H	22	52	17.5	33.5	16.3	36	358	333	303
KUSE 25 H	28	67	22.9	43	21.3	46	535	486	442
KUSE 30 H	40	80	33	60	30.5	64	896	762	694
KUSE 35 H	55	102	45	79	42	85	1,454	1,173	1,069
KUSE 45 H	80	174	65	117	59	126	2,794	2,237	2,037
KUSE 55 H	102	230	81	147	75	157	4,114	3,141	2,861



Linear Recirculating Ball Bearing And Guideway Assemblies

KUSE..HL SERIES

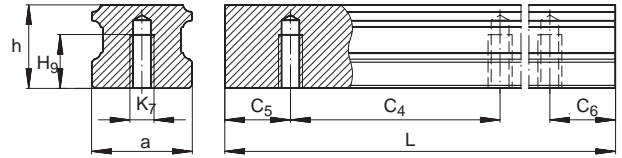

Guideway TKSD..U for mounting from below, suffix U (example: KUSE..U)

For details on part numbers, descriptive suffixes and various technical references, please refer to front of this section.

For engineering or technical information contact your local sales representative or call Distributor Sales (800)523-6572 or Linear Sales (800)462-3399.

DIMENSION TABLE - Dimensions in mm														
UNIT		CARRIAGE		GUIDEWAY			DIMENSIONS				MOUNTING DIMENSIONS			
PART NUMBER	PART NUMBER	MASS	PART NUMBER	MASS	CLOSING PLUGS	COVERING STRIP	L ¹⁾	H	A	C ²⁾	A ₁	A ₂	a	a ₃
		kg		kg/m									-0.05 -0.03	
KUSE 20 HL	KWSE 20 HL	0.44	TKSD 20	2.3	KA 10 TN	ADB 13	1,980	30	44	90.8	12	32	20	6
KUSE 25 HL	KWSE 25 HL	0.7	TKSD 25	3.15	KA 11 TN	ADB 13	1,980	40	48	104	12.5	35	23	6.5
KUSE 30 HL	KWSE 30 HL	1.2	TKSD 30	4.4	KA 15 TN	ADB 18	2,000	45	60	118.7	16	40	28	10
KUSE 35 HL	KWSE 35 HL	1.8	TKSD 35	6.5	KA 15 TN	ADB 18	2,960	55	70	138.4	18	50	34	10
KUSE 45 HL	KWSE 45 HL	3.7	TKSD 45	11.3	KA 20 TN	ADB 23	2,940	70	86	172.2	20.5	60	45	13
KUSE 55 HL	KWSE 55 HL	5.9	TKSD 55	15.7	KA 24 TN	ADB 23	2,520	80	100	198	23.5	75	53	12.5

- 1) Maximum length L of single piece guideway; longer guideways are supplied as multi-piece guideways and are marked accordingly.
- 2) Minimum covered length for sealing the lubrication connections.
- 3) Dimensions C₅ and C₆ are dependent on the guideway length L.
- 4) Position of the lubrication hole in the adjacent construction.
- 5) Maximum diameter of the lubrication hole in the adjacent construction.
- 6) If there is a possibility of settling, the fixing screws should be secured against rotation.

DIAMETERS AND TIGHTENING TORQUES FOR THREADS AND SCREWS ⁶⁾						
PART NUMBER	K ₁ for screws to DIN 912-12.9		K ₂ for screws to DIN 912-12.9		K ₇ for screws to DIN 912-12.9	
		Nm max.		Nm max.		Nm max.
KUSE 20 HL	M5	10	M5	10	M6	17
KUSE 25 HL	M6	17	M6	17	M6	17
KUSE 30 HL	M8	41	M8	41	M8	41
KUSE 35 HL	M8	41	M8	41	M8	41
KUSE 45 HL	M12	140	M10	83	M12	140
KUSE 55 HL	M14	220	M12	140	M14	220



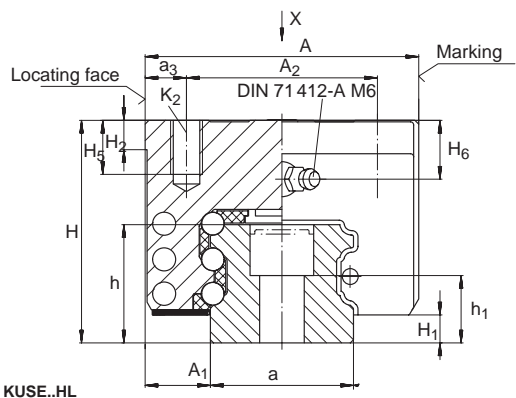

KUSE..HL

KUSE..HL, plan view X (rotated through 90°)

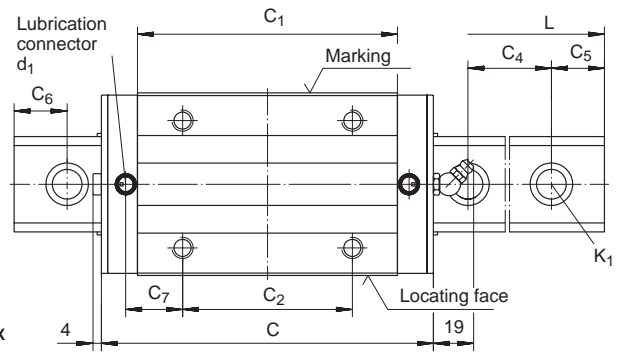

C ₁	C ₂	C ₄	C ₅ ³⁾		C ₆ ³⁾		C ₇ ⁴⁾	d ₁ ⁵⁾	H ₁	H ₂	H ₅	H ₆	H ₉	h	h ₁
			min	max.	min.	max.									
71.8	50	60	20	53	20	53	14.7	3	4.6	5	6.25	5.8	10	18	10.3
83	50	60	20	53	20	53	21.5	3	5.2	5	10	10	12	21.7	12.7
94.7	60	80	20	71	20	71	22.3	4.5	5.5	6	11	9.5	15	25	14
109.4	72	80	20	71	20	71	22.5	4.5	6.6	6.5	14	14.2	15	29.7	18.7
138.2	80	105	20	94	20	94	33.6	6	8.6	9	17	18.5	20	37.2	21.2
157.7	95	120	20	107	20	107	39.2	6	10.8	12	19	20	22	44	27

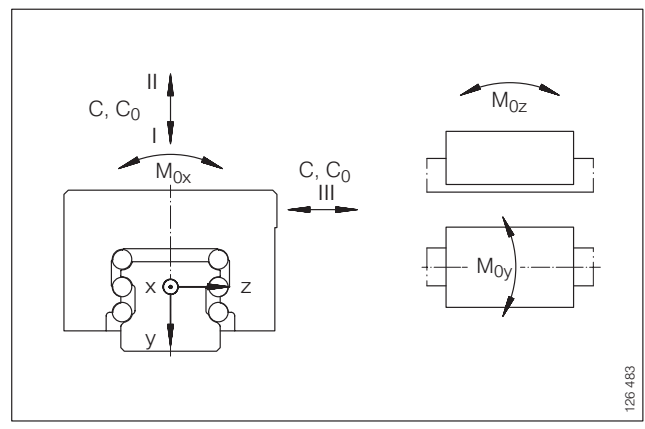

Load directions

PART NUMBER	BASIC LOAD RATINGS						MOMENT RATINGS		
	LOAD DIRECTION I: COMPRESSIVE LOAD		LOAD DIRECTION II: TENSILE LOAD		LOAD DIRECTION III: LATERAL LOAD		M _{0x} Nm	M _{0y} Nm	M _{0z} Nm
	C kN	C ₀ kN	C kN	C ₀ kN	C kN	C ₀ kN			
KUSE 20 HL	28	72	22.2	46.5	18.9	50	494	619	564
KUSE 25 HL	35.3	93.7	28.9	59.8	24.7	64	736	903	823
KUSE 30 HL	51	113	42.4	84.3	36.5	90	1,265	1,478	1,346
KUSE 35 HL	70	145	57.3	112.4	49.5	120	2,054	2,275	2,072
KUSE 45 HL	98	236	79.3	159	69	170	3,792	4,011	3,654
KUSE 55 HL	125.4	312	100.6	199.4	87	214	5,584	5,633	5,132



Sheet Steel Wiper APLSE SERIES

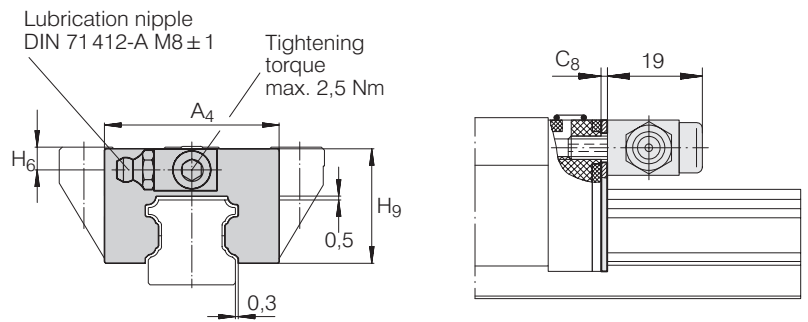

For details on part numbers, descriptive suffixes and various technical references, please refer to front of this section.

For engineering or technical information contact your local sales representative or call Distributor Sales (800)523-6572 or Linear Sales (800)462-3399.

DIMENSION TABLE - Dimensions in mm

PART NUMBER	MASS g	DIMENSIONS				SUITABLE FOR LINEAR RECIRCULATING BALL BEARING AND GUIDEWAY ASSEMBLY	
		A ₄	H ₉	C ₈	H ₆		
APLSE 20	26	42.8	24.9	0.8	5.8	KUSE 20	KUSE 20 L
					5.8	KUSE 20 H	KUSE 20 HL
APLSE 25	27	46	30.1	0.8	6	KUSE 25	KUSE 25 L
					10	KUSE 25 H	KUSE 25 HL
APLSE 30	31	58	35.8	0.8	6.5	KUSE 30	KUSE 30 L
					9.5	KUSE 30 H	KUSE 30 HL
APLSe 35	34	68	40.7	0.8	7.2	KUSE 35	KUSE 35 L
					14.2	KUSE 35 H	KUSE 35 HL
APLSE 45	40	84	50.7	0.8	8.5	KUSE 45	KUSE 45 L
					8.5	KUSE 45 H	KUSE 45 HL
APLSE 55	46	96.4	58.5	0.8	10	KUSE 55	KUSE 55 L
					20	KUSE 55 H	KUSE 55 HL

When fitting the wiper, it must be ensured that the gap between the guideway and the sheet steel wiper is of the correct size (see figure above).



Collector Wiper

AB KOL KWSE SERIES

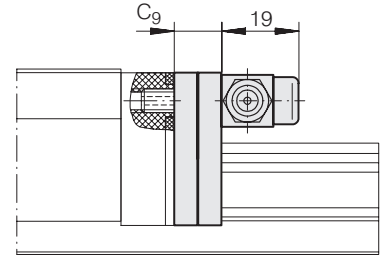
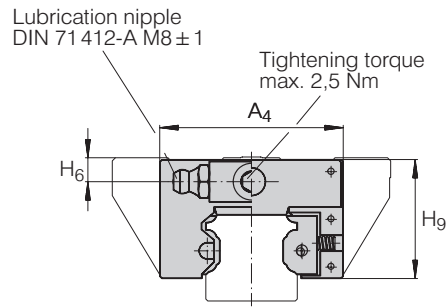

For details on part numbers, descriptive suffixes and various technical references, please refer to front of this section.

For engineering or technical information contact your local sales representative or call Distributor Sales (800)523-6572 or Linear Sales (800)462-3399.

DIMENSION TABLE - Dimensions in mm							
PART NUMBER	MASS g	DIMENSIONS				SUITABLE FOR LINEAR RECIRCULATING BALL BEARING AND GUIDEWAY ASSEMBLY	
		A ₄	H ₉	C ₉	H ₆		
AB KOL KWSE 20	46	42.8	24.9	9	5.8	KUSE 20	KUSE 20 L
					5.8	KUSE 20 H	KUSE 20 HL
AB KOL KWSE 25	51	46	30.1	9	6	KUSE 25	KUSE 25 L
					10	KUSE 25 H	KUSE 25 HL
AB KOL KWSE 30	69	58	35.8	9	6.5	KUSE 30	KUSE 30 L
					9.5	KUSE 30 H	KUSE 30 HL
AB KOL KWSE 35	82	68	40.7	9	7.2	KUSE 35	KUSE 35 L
					14.2	KUSE 35 H	KUSE 35 HL
AB KOL KWSE 45	109	84	50.7	11	8.5	KUSE 45	KUSE 45 L
					18.5	KUSE 45 H	KUSE 45 HL
AB KOL KWSE 55	136	96.4	58.5	11	10	KUSE 55	KUSE 55 L
					20	KUSE 55 H	KUSE 55 HL

If the collector wiper AB KOL KWSE is used,
the covering strip ADBSE or closing plugs KA..M must be used.

Lubrication Adapter Plate BPLSE SERIES

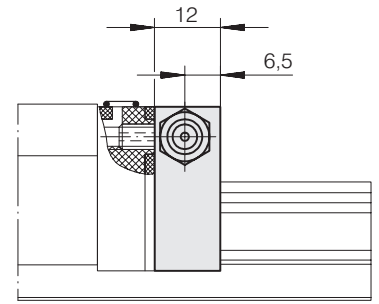
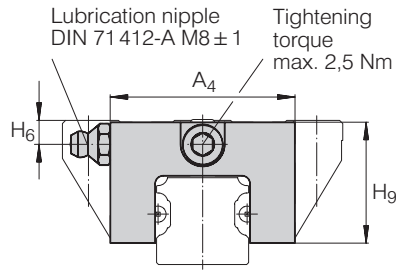

For details on part numbers, descriptive suffixes and various technical references, please refer to front of this section.

For engineering or technical information contact your local sales representative or call Distributor Sales (800)523-6572 or Linear Sales (800)462-3399.

DIMENSION TABLE - Dimensions in mm						
PART NUMBER	Mass g	DIMENSIONS			SUITABLE FOR LINEAR RECIRCULATING BALL BEARING AND GUIDEWAY ASSEMBLY	
		A ₄	H ₉	H ₆		
BPLSE 20	29	42.8	24.9	5.8	KUSE 20	KUSE 20 L
				5.8	KUSE 20 H	KUSE 20 HL
BPLSE 25	35	46	30.1	6	KUSE 25	KUSE 25 L
				10	KUSE 25 H	KUSE 25 HL
BPLSE 30	52	58	35.8	6.5	KUSE 30	KUSE 30 L
				9.5	KUSE 30 H	KUSE 30 HL
BPLSE 35	67	68	40.7	7.2	KUSE 35	KUSE 35 L
				14.2	KUSE 35 H	KUSE 35 HL
BPLSE 45	98	84	50.7	8.5	KUSE 45	KUSE 45 L
				18.5	KUSE 45 H	KUSE 45 HL
BPLSE 55	128	96.4	58.5	10	KUSE 55	KUSE 55 L
				20	KUSE 55 H	KUSE 55 HL

The lubrication nipple to DIN 71412-A M8 ± 1
can be replaced by a screw plug M8 ± 1.

Note:

In series KUSE..H and KUSE..HL, the lubrication nipple protrudes
about 9 mm from the side of the carriage.

Bellows

FBALG KWSE SERIES

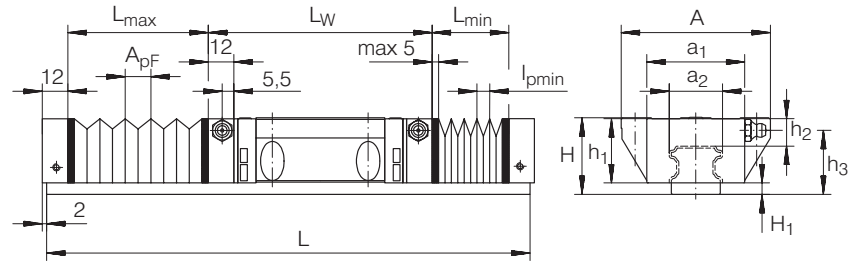

For details on part numbers, descriptive suffixes and various technical references, please refer to front of this section.

For engineering or technical information contact your local sales representative or call Distributor Sales (800)523-6572 or Linear Sales (800)462-3399.

Dimension table - Dimensions in mm												
PART NUMBER	DIMENSIONS										SUITABLE FOR LINEAR RECIRCULATING BALL BEARING AND GUIDEWAY ASSEMBLY	
	A	a ₁ ¹⁾	a ₂	H	H ₁	h ₁	h ₂	h ₃	A _{pF} ²⁾	l _{p min} ³⁾		
FBALG KWSE 20	63	42.8	21	30	4.8	24.9	11	24.2	14.5	2.5	KUSE 20	KUSE 20 L
	44			30							KUSE 20 H	KUSE 20 HL
FBALG KWSE 25	70	46	24	36	5.4	30.1	11	30	14.5	2.5	KUSE 25	KUSE 25 L
	48			40							KUSE 25 H	KUSE 25 HL
FBALG KWSE 30	90	58	29	42	5.7	35.8	14	35.5	18	2.5	KUSE 30	KUSE 30 L
	60			45							KUSE 30 H	KUSE 30 HL
FBALG KWSE 35	100	68	35	48	6.8	40.7	16	40.8	22.5	2.5	KUSE 35	KUSE 35 L
	70			55							KUSE 35 H	KUSE 35 HL
FBALG KWSE 45	120	84	46	60	8.8	50.7	19	51.5	27	2.5	KUSE 45	KUSE 45 L
	86			70							KUSE 45 H	KUSE 45 HL
FBALG KWSE 55	140	96.4	56	70	11	58.5	21	60	31.5	2.5	KUSE 55	KUSE 55 L
	100			80							KUSE 55 H	KUSE 55 HL

1) Maximum width of bellows in end gauge.

2) Expansion per pleat.

3) Compression per pleat.

Four-Row Linear Recirculating Ball Bearing And Guideway Assembly

KUVE, KUVE..L, KUVE..N SERIES

For details on part numbers, descriptive suffixes and various technical references, please refer to front of this section.
For engineering or technical information contact your local sales representative or call Distributor Sales (800)523-6572.

DIMENSION TABLE • Dimensions in mm													
UNIT	CARRIAGE		GUIDEWAYS			DIMENSIONS				MOUNTING DIMENSIONS			
PART NUMBER	PART NUMBER	MASS kg	PART NUMBER	MASS kg/m	CLOSING PLUGS	L ¹⁾	H	A	C	A ₁	A ₂	a -0.005 -0.03	a ₃
KUVE 15	KWVE 15	0.25	TKVD 15	1.5	KA 08 TN A	1200	24	47	55.6	16	38	15	4.5
KUVE 20	KWVE 20	0.58	TKVD 20	2.2	KA 10 TN A	1980	30	63	69.8	21.5	53	20	5
KUVE 20 L	KWVE 20 L	0.8	TKVD 20	2.2	KA 10 TN A	1980	30	63	87.3	21.5	53	20	5
KUVE 20 N	KWVE 20 N	0.47	TKVD 20	2.2	KA 10 TN A	1980	27	63	69.8	21.5	53	20	5
KUVE 25	KWVE 25	0.71	TKVD 25	2.7	KA 11 TN A	1980	36	70	81.7	23.5	57	23	6.5
KUVE 25 L	KWVE 25 L	1	TKVD 25	2.7	KA 11 TN A	1980	36	70	107.5	23.5	57	23	6.5
KUVE 25 N	KWVE 25 N	0.57	TKVD 25	2.7	KA 11 TN A	1980	31	70	81.7	23.5	57	23	6.5
KUVE 30	KWVE 30	1.4	TKVD 30	4.3	KA 15 TN A	2000	42	90	97.6	31	72	28	9
KUVE 30 L	KWVE 30 L	1.83	TKVD 30	4.3	KA 15 TN A	2000	42	90	122.6	31	72	28	9
KUVE 30 N	KWVE 30 N	1.12	TKVD 30	4.3	KA 15 TN A	2000	38	90	97.6	31	72	28	9
KUVE 35	KWVE 35	2.02	TKVD 35	5.7	KA 15 TN A	2960	48	100	110.4	33	82	34	9
KUVE 35 L	KWVE 35 L	2.71	TKVD 35	5.7	KA 15 TN A	2960	48	100	140.2	33	82	34	9
KUVE 35 N	KWVE 35 N	1.62	TKVD 35	5.7	KA 15 TN A	2960	44	100	110.4	33	82	34	9
KUVE 45	KWVE 45	3.75	TKVD 45	9.2	KA 20 TN A	2940	60	120	139	37.5	100	45	10
KUVE 45 L	KWVE 45 L	4.7	TKVD 45	9.2	KA 20 TN A	2940	60	120	167.5	37.5	100	45	10
KUVE 45 N	KWVE 45 N	3	TKVD 45	9.2	KA 20 TN A	2940	52	120	139	37.5	100	45	10

- 1) Maximum length L of single piece guideway;
longer guideways are supplied as multi-piece guideways and are marked accordingly.
- 2) Dimensions C₂ and C₅ are dependent on the guideway length L; see page NO TAG for calculation method.
- 3) When mounting from above: maximum length of fixing screw for the central fixing holes H₆+3mm.
- 4) If there is a possibility of settling, the fixing screws should be secured against rotation.

DIAMETERS AND TIGHTENING TORQUES FOR THREADS AND SCREWS ⁴⁾										
PART NUMBER	K ₁ For screws to DIN 912-12.9		K ₂ For screws to DIN 912-12.9		K ₃ Through holes for screws to DIN 912-12.9		K ₆ Through holes for screws to DIN 7 984-8.8		K ₆ Through holes for screws to DIN 912-12.9	
		Nm max.		Nm max.		Nm max.		Nm max.		Nm max.
KUVE 15	M4	5	M5	5.8	M4	5	M4	2.8	-	-
KUVE 20	M5	10	M6	10	M5	10	-	-	M5	10
KUVE 20 L	M5	10	M6	10	M5	10	-	-	M5	10
KUVE 20 N	M5	10	M6	10	M5	10	M5	5.8	-	-
KUVE 25	M6	17	M8	24	M6	17	-	-	M6	17
KUVE 25 L	M6	17	M8	24	M6	17	-	-	M6	17
KUVE 25 N	M6	17	M8	24	M6	17	M6	10	-	-
KUVE 30	M8	41	M10	41	M8	41	M8	24	-	-
KUVE 30 L	M8	41	M10	41	M8	41	M8	24	-	-
KUVE 30 N	M8	41	M10	41	M8	41	M8	24	-	-
KUVE 35	M8	41	M10	41	M8	41	-	-	M8	41
KUVE 35 L	M8	41	M10	41	M8	41	-	-	M8	41
KUVE 35 N	M8	41	M10	41	M8	41	M8	24	-	-
KUVE 45	M12	140	M12	83	M10	83	-	-	M10	83
KUVE 45 L	M12	140	M12	83	M10	83	-	-	M10	83
KUVE 45 N	M12	140	M12	83	M10	83	M10	48	-	-



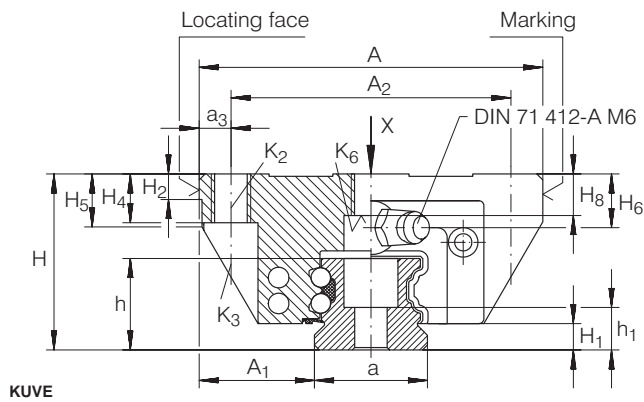

KUVE, plan view X (rotated through 90°)

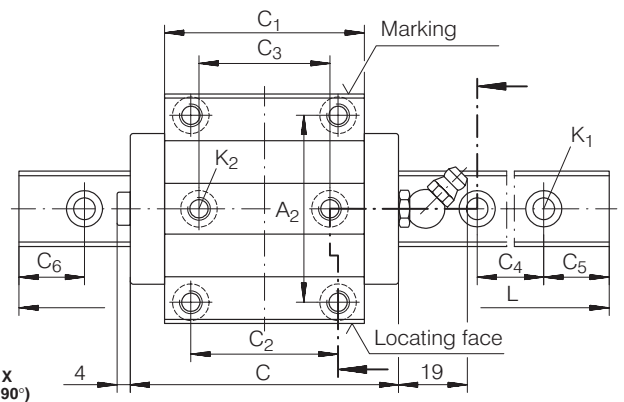

DIMENSION TABLE • Dimensions in mm

MOUNTING DIMENSIONS															
C ₁	C ₂	C ₃	C ₄	C ₅ ²⁾ min.	C ₅ ²⁾ max.	C ₆ ²⁾ min.	C ₆ ²⁾ max.	H ₁	H ₂	H ₄	H ₅	H ₆	H ₈ ³⁾	h	h ₁
39.8	30	26	60	20	53	20	53	4.5	4.5	7.6	7.6	4	5.8	15.1	8.2
50.4	40	35	60	20	53	20	53	4.8	5	10	11	4.8	7.5	17	9.1
67.9	40	35	60	20	53	20	53	4.8	5	10	11	4.8	7.5	17	9.1
50.4	40	35	60	20	53	20	53	4.8	5	8	8.6	4.8	6	17	9.1
60.7	45	40	60	20	53	20	53	5.4	5	10	10.9	4.8	10	18.7	8.7
86.5	45	40	60	20	53	20	53	5.4	5	10	10.9	4.8	10	18.7	8.7
60.7	45	40	60	20	53	20	53	5.4	5	10	9.3	4.8	8	18.7	8.7
72	52	44	80	20	71	20	71	6.2	6	12	13.8	4.8	12	23.5	11.5
97	52	44	80	20	71	20	71	6.2	6	12	13.8	4.8	12	23.5	11.5
72	52	44	80	20	71	20	71	6.2	6	12	9.8	4.8	9	23.5	11.5
80	62	52	80	20	71	20	71	7	6.5	13	14.3	4.8	12	27	15
109.8	62	52	80	20	71	20	71	7	6.5	13	14.3	4.8	12	27	15
80	62	52	80	20	71	20	71	7	6.5	13	10.3	4.8	11.7	27	15
102.5	80	60	105	20	94	20	94	10	9	15	19.8	4.8	15	34.2	16.2
131.1	80	60	105	20	94	20	94	10	9	15	19.8	4.8	15	34.2	16.2
102.5	80	60	105	20	94	20	94	10	9	15	17.2	4.8	11	34.2	16.2

LOAD CARRYING CAPACITY TABLE

PART NUMBER	BASIC LOAD RATINGS		MOMENT RATINGS		
	C	C ₀	M _{0x}	M _{0y}	M _{0z}
	kN	kN	Nm	Nm	Nm
KUVE 15	7.2	14.5	150	100	100
KUVE 20	13.1	27	332	240	240
KUVE 20 L	16.2	36.5	452	430	430
KUVE 20 N	13.1	27	332	240	240
KUVE 25	17.9	37	510	395	395
KUVE 25 L	23.4	54	745	825	825
KUVE 25 N	17.9	37	510	395	395
KUVE 30	27.5	55	970	700	700
KUVE 30 L	34.5	74	1310	1240	1240
KUVE 30 N	27.5	55	970	700	700
KUVE 35	38	72	1465	1020	1020
KUVE 35 L	47.5	100	2025	1890	1890
KUVE 35 N	38	72	1465	1020	1020
KUVE 45	69	141	3610	2485	2485
KUVE 45 L	82	181	4635	4000	4000
KUVE 45 N	69	141	3610	2485	2485

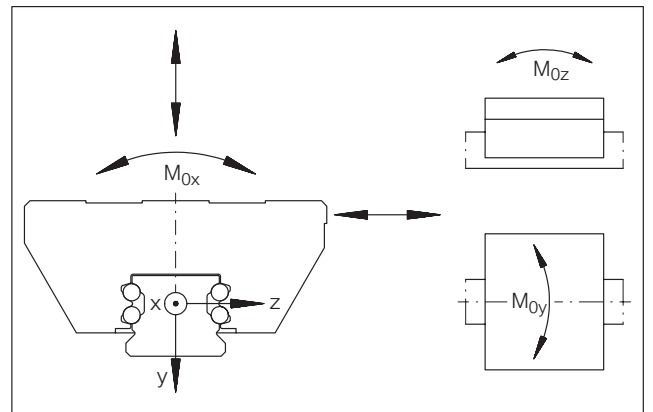

Load directions



Four-Row Linear Recirculating Ball Bearing And Guideway Assembly

KUVE..S, KUVE..SN, KUVE..H SERIES

For details on part numbers, descriptive suffixes and various technical references, please refer to front of this section.
For engineering or technical information contact your local sales representative or call Distributor Sales (800)523-6572.

DIMENSION TABLE • Dimensions in mm													
UNIT	CARRIAGE		GUIDEWAYS			DIMENSIONS				MOUNTING DIMENSIONS			
PART NUMBER	PART NUMBER	MASS kg	PART NUMBER	MASS kg/m	CLOSING PLUGS	L ¹⁾	H	A	C	A ₁	A ₂	a -0.005 -0.03	a ₃
KUVE 15 S	KWVE 15 S	0.19	TKVD 15	1.5	KA 08 TN A	1200	24	34	55.6	9.5	26	15	4
KUVE 15 H	KWVE 15 H	0.23	TKVD 15	1.5	KA 08 TN A	1200	28	34	55.6	9.5	26	15	4
KUVE 20 S	KWVE 20 S	0.46	TKVD 20	2.2	KA 10 TN A	1980	30	44	69.8	12	32	20	6
KUVE 20 SN	KWVE 20 SN	0.36	TKVD 20	2.2	KA 10 TN A	1980	27	44	69.8	12	32	20	6
KUVE 25 S	KWVE 25 S	0.56	TKVD 25	2.7	KA 11 TN A	1980	36	48	81.7	12.5	35	23	6.5
KUVE 25 SN	KWVE 25 SN	0.45	TKVD 25	2.7	KA 11 TN A	1980	31	48	81.7	12.5	35	23	6.5
KUVE 25 H	KWVE 25 H	0.65	TKVD 25	2.7	KA 11 TN A	1980	40	48	81.7	12.5	35	23	6.5
KUVE 30 S	KWVE 30 S	1.09	TKVD 30	4.3	KA 15 TN A	2000	42	60	97.6	16	40	28	10
KUVE 30 SN	KWVE 30 SN	0.87	TKVD 30	4.3	KA 15 TN A	2000	38	60	97.6	16	40	28	10
KUVE 30 H	KWVE 30 H	1.27	TKVD 30	4.3	KA 15 TN A	2000	45	60	97.6	16	40	28	10
KUVE 35 S	KWVE 35 S	1.6	TKVD 35	5.7	KA 15 TN A	2960	48	70	110.4	18	50	34	10
KUVE 35 SN	KWVE 35 SN	1.27	TKVD 35	5.7	KA 15 TN A	2960	44	70	110.4	18	50	34	10
KUVE 35 H	KWVE 35 H	1.84	TKVD 35	5.7	KA 15 TN A	2960	55	70	110.4	18	50	34	10
KUVE 45 S	KWVE 45 S	2.8	TKVD 45	9.2	KA 20 TN A	2940	60	86	139	20.5	60	45	13
KUVE 45 SN	KWVE 45 SN	2.3	TKVD 45	9.2	KA 20 TN A	2940	52	86	139	20.5	60	45	13
KUVE 45 H	KWVE 45 H	3.5	TKVD 45	9.2	KA 20 TN A	2940	70	86	139	20.5	60	45	13

- 1) Maximum length L of single piece guideway;
longer guideways are supplied as multi-piece guideways and are marked accordingly.
2) Dimensions C₂ and C₅ are dependent on the guideway length L; see page NO TAG for calculation method.
3) When mounting from above: maximum length of fixing screw for the central fixing holes H₆+3mm.
4) If there is a possibility of settling, the fixing screws should be secured against rotation.

DIAMETERS AND TIGHTENING TORQUES FOR THREADS AND SCREWS ⁴⁾				
PART NUMBER	K ₁ for screws to DIN 912-12.9		K ₂ for screws to DIN 912-12.9	
		Nm max.		Nm max.
KUVE 15 S	M4	5	M4	5
KUVE 15 H	M4	5	M4	5
KUVE 20 S	M5	10	M5	10
KUVE 20 SN	M5	10	M5	10
KUVE 25 S	M6	17	M6	17
KUVE 25 SN	M6	17	M6	17
KUVE 25 H	M6	17	M6	17
KUVE 30 S	M8	41	M8	41
KUVE 30 SN	M8	41	M8	41
KUVE 30 H	M8	41	M8	41
KUVE 35 S	M8	41	M8	41
KUVE 35 SN	M8	41	M8	41
KUVE 35 H	M8	41	M8	41
KUVE 45 S	M12	140	M10	83
KUVE 45 SN	M12	140	M10	83
KUVE 45 H	M12	140	M10	83



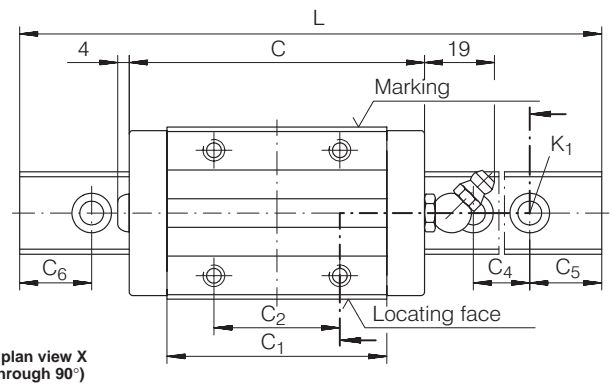
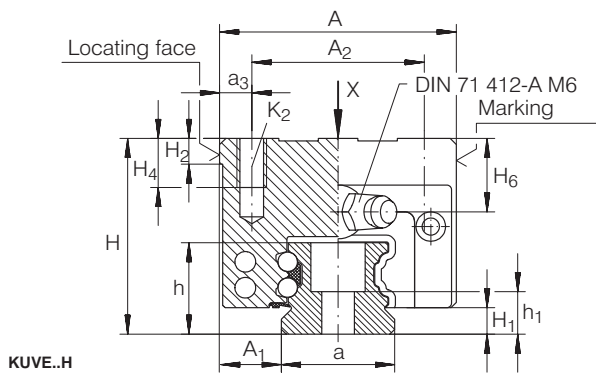

KUVE..H, plan view X (rotated through 90°)

DIMENSION TABLE • Dimensions in mm

MOUNTING DIMENSIONS

C ₁	C ₂	C ₄	C ₅ ²⁾ min.	C ₅ ²⁾ max.	C ₆ ²⁾ min.	C ₆ ²⁾ max.	H ₁	H ₂	H ₄	H ₆	h	h ₁
39.8	26	60	20	53	20	53	4.5	4.5	6	4	15.1	8.2
39.8	26	60	20	53	20	53	4.5	4.5	6	8	15.1	8.2
50.4	36	60	20	53	20	53	4.8	5	7.5	8	17	9.1
50.4	36	60	20	53	20	53	4.8	5	7.5	5	17	9.1
60.7	35	60	20	53	20	53	5.4	5	10	11	18.7	8.7
60.7	35	60	20	53	20	53	5.4	5	8	6	18.7	8.7
60.7	35	60	20	53	20	53	5.4	5	10	15	18.7	8.7
72	40	80	20	71	20	71	6.2	6	13.5	11.25	23.5	11.5
72	40	80	20	71	20	71	6.2	6	11	7.25	23.5	11.5
72	40	80	20	71	20	71	6.2	6	13.5	14.25	23.5	11.5
80	50	80	20	71	20	71	7	6.5	13.5	12.3	27	15
80	50	80	20	71	20	71	7	6.5	13.5	8.3	27	15
80	50	80	20	71	20	71	7	6.5	13.5	19.3	27	15
102.5	60	105	20	94	20	94	10	9	17	16.5	34.2	16.2
102.5	60	105	20	94	20	94	10	9	16.5	8.5	34.2	16.2
102.5	60	105	20	94	20	94	10	9	17	26.5	34.2	16.2

LOAD CARRYING CAPACITY TABLE

PART NUMBER	BASIC LOAD RATINGS		MOMENT RATINGS		
	C	C ₀	M _{0x}	M _{0y}	M _{0z}
	kN	kN	Nm	Nm	Nm
KUVE 15 S	7.2	14.5	150	100	100
KUVE 15 H	7.2	14.5	150	100	100
KUVE 20 S	13.1	27	332	240	240
KUVE 20 SN	13.1	27	332	240	240
KUVE 25 S	17.9	37	510	395	395
KUVE 25 SN	17.9	37	510	395	395
KUVE 25 H	17.9	37	510	395	395
KUVE 30 S	27.5	55	970	700	700
KUVE 30 SN	27.5	55	970	700	700
KUVE 30 H	27.5	55	970	700	700
KUVE 35 S	38	72	1465	1020	1020
KUVE 35 SN	38	72	1465	1020	1020
KUVE 35 H	38	72	1465	1020	1020
KUVE 45 S	69	141	3610	2485	2485
KUVE 45 SN	69	141	3610	2485	2485
KUVE 45 H	69	141	3610	2485	2485

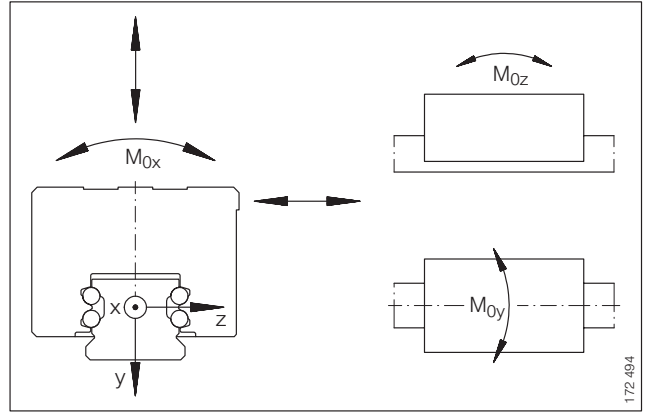

Load directions



Four-row Linear Recirculating Ball Bearing And Guideway Assembly

KUVE..W, KUVE..WL SERIES

For details on part numbers, descriptive suffixes and various technical references, please refer to front of this section.

For engineering or technical information contact your local sales representative or call Distributor Sales (800)523-6572 or Linear Sales (800)462-3399.

DIMENSION TABLE - Dimensions in mm													
UNIT PART NUMBER	CARRIAGE		GUIDEWAY			DIMENSIONS				MOUNTING DIMENSIONS			
	PART NUMBER	MASS kg	PART NUMBER	MASS kg/m	CLOSING PLUGS	L ¹⁾	H	A	C	A ₁	A ₂	A ₄	A ₅
KUVE 20 W	KWVE 20 W	0.56	TKVD 20 W	5	KA 08..A	1,500	27	80	69.8	19	70	24	9
KUVE 25 WL	KWVE 25 WL	1.46	TKVD 25 W	9.4	KA 11..A	1,980	35	120	107.8	25.5	107	40	14.5
KUVE 30 W	KWVE 30 W	1.95	TKVD 30 W	13.6	KA 15..A	2,000	42	142	97.6	31	124	50	15
KUVE 35 WL	KWVE 35 WL	4.11	TKVD 35 W	17.4	KA 15..A	2,960	50	162	140.2	36	144	60	15

- 1) Maximum length L of single piece guideway; longer guideways are supplied as multi-piece guideways and are marked accordingly.
- 2) Dimensions C₅ and C₆ are dependent on the guideway length L.
- 3) When mounting from above: maximum length of fixing screw for the central fixing holes H₈ +3 mm.
- 4) If there is a possibility of settling, the fixing screws should be secured against rotation.

DIAMETERS AND TIGHTENING TORQUES FOR THREADS AND SCREWS ⁵⁾										
PART NUMBER	K ₁ for screws to DIN 912-12.9		K ₂ for screws to DIN 912-12.9		K ₃ for screws to DIN 912-12.9		K ₆ for screws to DIN 7984-8.8		K ₆ for screws to DIN 912-12.9	
		Nm max.		Nm max.		Nm max.		Nm max.		Nm max.
KUVE 20 W	M4	5	M6	10	M5	10	M5	5.8	-	-
KUVE 25 WL	M6	17	M8	24	M6	17	-	-	M6	17
KUVE 30 W	M8	41	M10	41	M8	41	M8	24	-	-
KUVE 35 WL	M8	41	M10	41	M8	41	-	-	M8	41



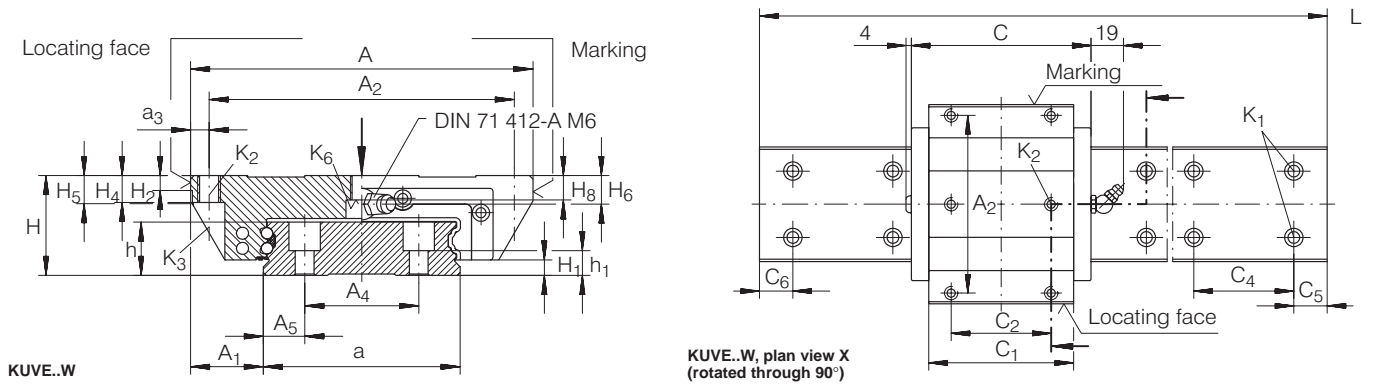

a -0.005 -0.030	a ₃	C ₁	C ₂	C ₄	C ₅ ²⁾		C ₆ ²⁾		H ₁	H ₂	H ₄	H ₅	H ₆	H ₈ ³⁾	h	h ₁
					min.	max.	min.	max.								
42	5	50.4	40	60	20	53	20	53	4.6	5	10	10.6	5	6	17	10
69	6.5	86.5	60	80	20	71	20	71	5.2	5	10	9.9	10	10	18.7	8.7
80	9	72	52	80	20	71	20	71	6	6	12	13.8	11.25	12	23.5	11.5
90	9	109.8	80	80	20	71	20	71	6.8	6.5	13	16.3	14.3	13	27	15

LOAD CARRYING CAPACITY TABLE						
PART NUMBER	BASIC LOAD RATINGS		MOMENT RATINGS			
	C kN	C ₀ kN	M _{0x} Nm	M _{0y} Nm	M _{0z} Nm	
KUVE 20 W	13.1	26.9	687	240	240	
KUVE 25 WL	23.4	54	2,225	825	825	
KUVE 30 W	27.5	55	2,660	700	700	
KUVE 35 WL	47.5	100	5,550	1,890	1,890	

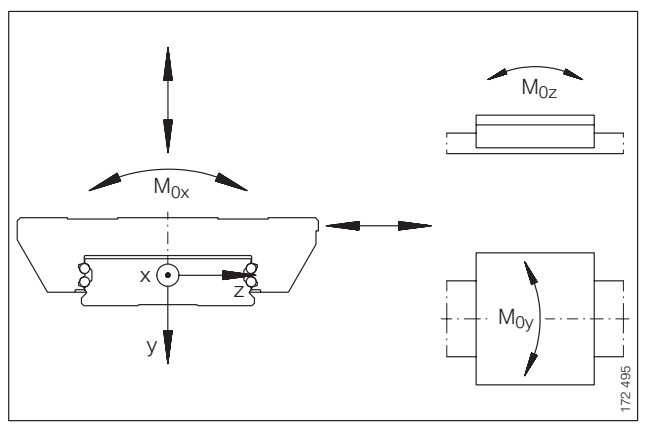

Load directions



Linear Recirculating Ball Bearing And Guideway Assemblies KUE SERIES

For details on part numbers, descriptive suffixes and various technical references, please refer to front of this section.

For engineering or technical information contact your local sales representative or call Distributor Sales (800)523-6572 or Linear Sales (800)462-3399.

DIMENSION TABLE - Dimensions in mm												
UNIT	CARRIAGE		GUIDEWAY		DIMENSIONS				MOUNTING DIMENSIONS			
PART NUMBER	PART NUMBER	MASS kg	PART NUMBER	MASS kg/m	L ¹⁾	H	A	C	A ₁	A ₂	a -0,004 -0,05	a ₃
KUE 15	KWE 15	0.17	TKD 15	1.5	1,200	24	47	54.5	16	38	15	4.5
KUE 20	KWE 20	0.45	TKD 20	2.2	1,980	30	63	70.5	21.5	53	20	5
KUE 25	KWE 25	0.65	TKD 25	2.8	1,980	36	70	80.7	23.5	57	23	6.5
KUE 30	KWE 30	1.2	TKD 30	4.2	2,000	42	90	93	31	72	28	9
KUE 35	KWE 35	1.7	TKD 35	5.6	2,960	48	100	106.4	33	82	34	9

- 1) Maximum length L of single piece guideway; longer guideways are supplied as multi-piece guideways.
- 2) Dimensions C₅ and C₆ are dependent on the guideway length L.
- 3) Lubrication nipple with tapered head to DIN 71 412, except for KUE 15 (drive fit lubrication nipple).
- 4) A drive fit lubrication nipple and closing plug are supplied loose with the carriage.
- 5) If there is a possibility of settling, the fixing screws should be secured against rotation.

DIAMETERS AND TIGHTENING TORQUES FOR THREADS AND SCREWS ⁵⁾							
PART NUMBER	K ₁ for screws to DIN 912-12.9		K ₂ for screws to DIN 912-12.9		K ₃ Through holes for screws to DIN 912-12.9		K ₅ ³⁾ Lubrication connector
		Nm max.		Nm max.		Nm max.	
KUE 15	M4	5	M5	5.8	M4	5	NIP A1 ⁴⁾
KUE 20	M5	10	M6	10	M5	10	NIP KE M6
KUE 25	M6	17	M8	24	M6	17	NIP KE M6
KUE 30	M8	41	M10	41	M8	41	NIP KE M6
KuE 35	M8	41	M10	41	M8	41	NIP KE M6



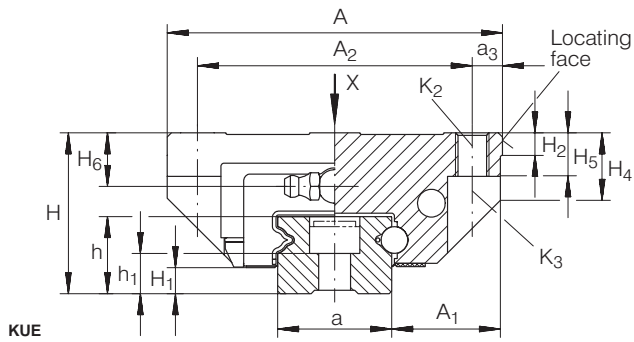

KUE

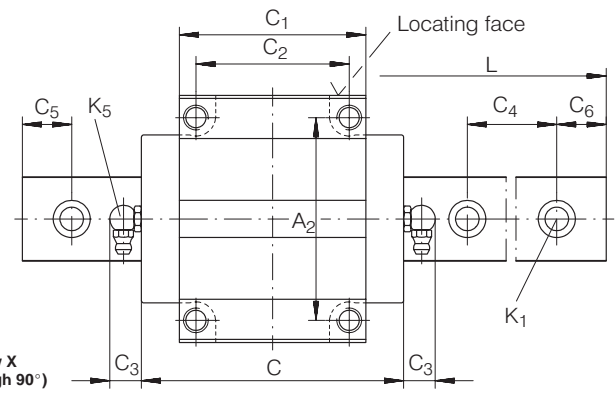

KUE, plan view X
(rotated through 90°)

C ₁	C ₂	C ₃	C ₄	C ₅ ²⁾		C ₆ ²⁾		H ₁	H ₂	H ₄	H ₅	H ₆	h	h ₁	ACCESSORIES CLOSING PLUGS
				min.	max.	min.	max.								
				38.6	30	1.5	60								
49.3	40	14	60	20	53	20	53	5	5	11.6	10	6.5	16.5	8.3	KA 10 TN
56.5	45	14	60	20	53	20	53	6.5	5	11.5	10	10	18	8.7	KA 11 TN
65.7	52	14	80	20	71	20	71	7	6	14.6	10	13	21.5	10	KA 15 TN
75.5	62	14	80	20	71	20	71	8	6.5	20.1	13	16	23	11.5	KA 15 TN

LOAD CARRYING CAPACITY TABLE					
PART NUMBER	BASIC LOAD RATINGS		MOMENT RATINGS		
	dyn. C kN	stat. C ₀ kN	M _{0x} Nm	M _{0y} Nm	M _{0z} Nm
KUE 15	6.5	9.2	73	56	56
KUE 20	13.3	18	190	154	154
KUE 25	16.2	20.9	253	185	185
KUE 30	22.5	29.7	437	335	335
KUE 35	28	37	658	450	450

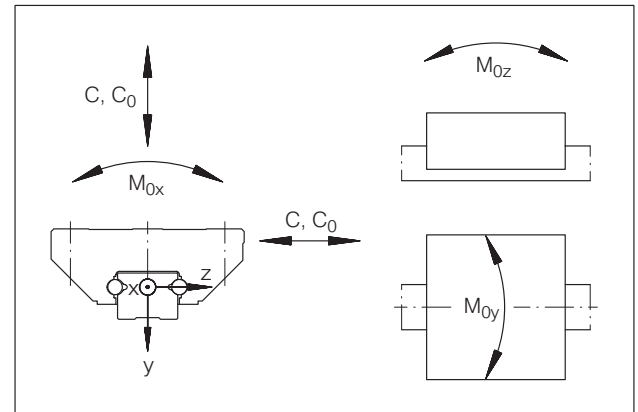

Load directions



Linear Recirculating Ball Bearing And Guideway Assemblies KUE..H SERIES

For details on part numbers, descriptive suffixes and various technical references, please refer to front of this section.

For engineering or technical information contact your local sales representative or call Distributor Sales (800)523-6572 or Linear Sales (800)462-3399.

DIMENSION TABLE - Dimensions in mm												
Unit PART NUMBER	CARRIAGE		GUIDEWAY		DIMENSIONS				MOUNTING DIMENSIONS			
	PART NUMBER	MASS kg	PART NUMBER	MASS kg/m	L ¹⁾	H	A	C	A ₁	A ₂	a -0.004 -0.05	a ₃
KUE 15 H	KWE 15 H	0.17	TKD 15	1.5	1,200	28	34	54.5	9.5	26	15	4
KUE 20 H	KWE 20 H	0.35	TKD 20	2.2	1,980	30	44	70.5	12	32	20	6
KUE 25 H	KWE 25 H	0.55	TKD 25	2.8	1,980	40	48	80.7	12.5	35	23	6.5
KUE 30 H	KWE 30 H	0.9	TKD 30	4.2	2,000	45	60	93	16	40	28	10
KUE 35 H	KWE 35 H	1.46	TKD 35	5.6	2,960	55	70	106.4	18	50	34	10

1) Maximum length L of single piece guideway; longer guideways are supplied as multi-piece guideways.

2) Dimensions C₅ and C₆ are dependent on the guideway length L.

3) Maximum length of fixing screw.

4) Lubrication nipple with tapered head to DIN 71 412, except for KUE 15 H (drive fit lubrication nipple).

5) A drive fit lubrication nipple and closing plug are supplied loose with the carriage.

6) If there is a possibility of settling, the fixing screws should be secured against rotation.

DIAMETERS AND TIGHTENING TORQUES FOR THREADS AND SCREWS ⁶⁾					
PART NUMBER	K ₁ for screws to DIN 912-12.9		K ₂ for screws to DIN 912-12.9		K ₅ ⁴⁾ Lubrication connector
		Nm max.		Nm max.	
KUE 15 H	M4	5	M4	5	NIP A1 ⁵⁾
KUE 20 H	M5	10	M5	10	NIP KE M6
KUE 25 H	M6	17	M6	17	NIP KE M6
KUE 30 H	M8	41	M8	41	NIP KE M6
KuE 35 H	M8	41	M8	41	NIP KE M6



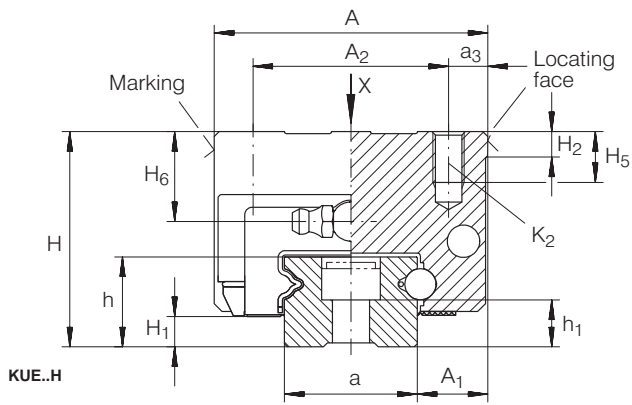

KUE, plan view X (rotated through 90°)

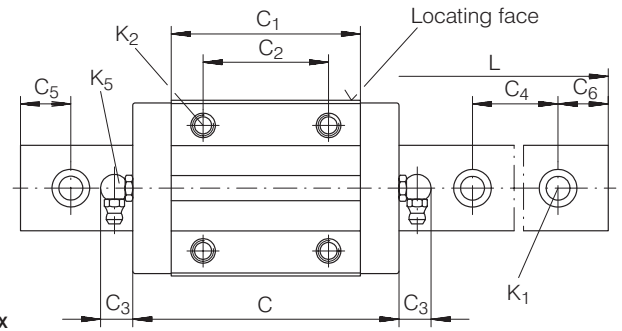

C ₁	C ₂	C ₃	C ₄	C ₅ ²⁾				C ₆ ²⁾				H ₁	H ₂	H ₅ ³⁾	H ₆	h	h ₁	ACCESSORIES CLOSING PLUGS
				min.		max.		min.		max.								
				min.	max.	min.	max.	min.	max.									
38.6	26	1.5	60	20	53	20	53	4.8	4.5	5	8	15	7.7					KA 08 TN
49.3	36	14	60	20	53	20	53	5	5	6.25	6.5	16.5	8.3					KA 10 TN
56.5	35	14	60	20	53	20	53	6.5	5	8	14	18	8.7					KA 11 TN
65.7	40	14	80	20	71	20	71	7	6	10	16	21.5	10					KA 15 TN
75.5	50	14	80	20	71	20	71	8	6.5	12	23	23	11.5					KA 15 TN

LOAD CARRYING CAPACITY TABLE					
PART NUMBER	BASIC LOAD RATINGS		MOMENT RATINGS		
	dyn. C kN	stat. C ₀ kN	M _{0x} Nm	M _{0y} Nm	M _{0z} Nm
KUE 15 H	6.5	9.2	73	56	56
KUE 20 H	13.3	18	190	154	154
KUE 25 H	16.2	20.9	253	185	185
KUE 30 H	22.5	29.7	437	335	335
KUE 35 H	28	37	658	450	450

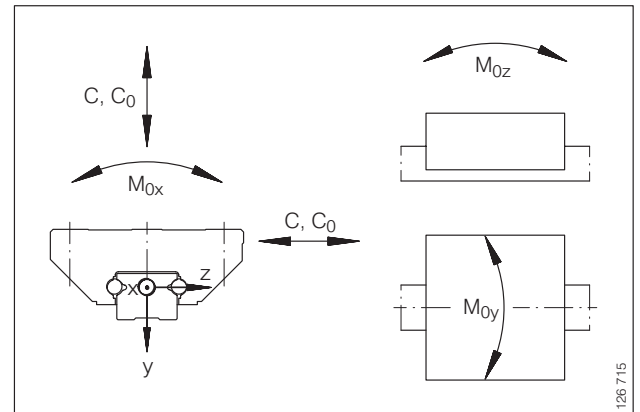

Load directions



Sheet Steel Wiper

APLE SERIES

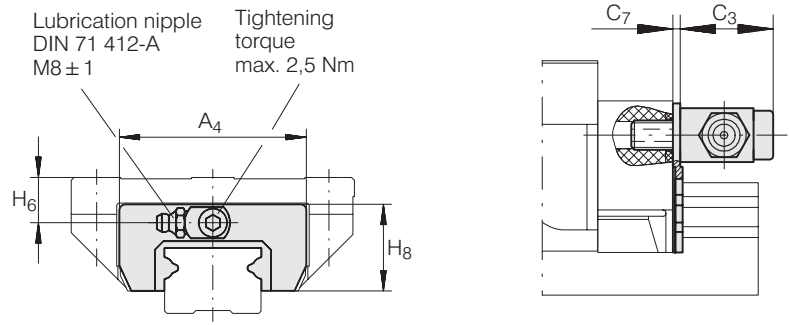

For details on part numbers, descriptive suffixes and various technical references, please refer to front of this section.

For engineering or technical information contact your local sales representative or call Distributor Sales (800)523-6572 or Linear Sales (800)462-3399.

DIMENSION TABLE - Dimensions in mm

PART NUMBER	MASS g	DIMENSIONS					SUITABLE FOR LINEAR RECIRCULATING BALL BEARING AND GUIDEWAY ASSEMBLY
		A ₄	H ₈	C ₃	C ₇	H ₆	
APLE 20	35	40	24	19	1.2	6.5	KUE 20
						6.5	KUE 20 H
APLE 25	39	44	25.3	19	1.2	10	KUE 25
						14	KUE 25 H
APLE 30	43	55	28	19	1.2	13	KUE 30
						16	KUE 30 H
APLE 35	47	66	30.5	19	1.5	16	KUE 35
						23	KUE 35 H

1) When fitting the sheet steel wiper, it must be ensured that there is an even gap of ca. 0.1 mm between the guideway and the wiper.



Lubrication Adapter Plate BPLE SERIES

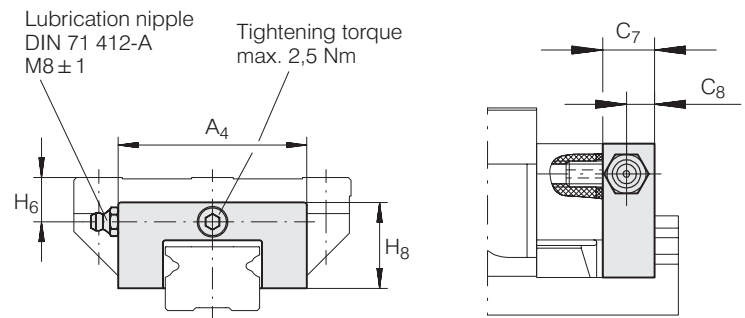

For details on part numbers, descriptive suffixes and various technical references, please refer to front of this section.

For engineering or technical information contact your local sales representative or call Distributor Sales (800)523-6572 or Linear Sales (800)462-3399.

DIMENSION TABLE - Dimensions in mm							
PART NUMBER	MASS g	DIMENSIONS					SUITABLE FOR LINEAR RECIRCULATING BALL BEARING AND GUIDEWAY ASSEMBLY
		A ₄	H ₈	C ₇	C ₈	H ₆	
BPLE 20	25	42	23.5	12	6.5	6.5	KUE 20
						6.5	KUE 20 H
BPLE 25	34	46.5	26	12	6.5	10	KUE 25
						14	KUE 25 H
BPLE 30	44	58	28	12	6.5	13	KUE 30
						16	KUE 30 H
BPLE 35	54	68	31	12	6.5	16	KUE 35
						23	KUE 35 H

The lubrication nipple to DIN 71 412-A M8 ± 1 can be replaced by a screw plug M8 ± 1.

Note:
In series KUE..H, the lubrication nipple protrudes about 9 mm from the side of the carriage.

Bellows

FBALG KWE SERIES

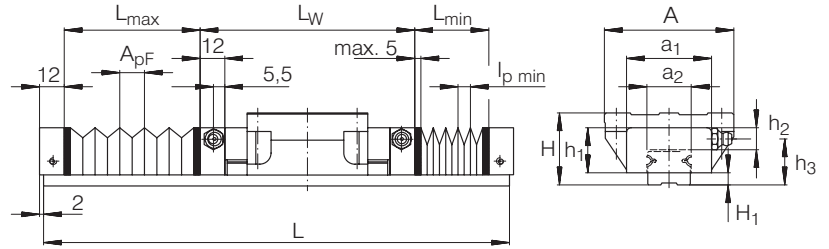

For details on part numbers, descriptive suffixes and various technical references, please refer to front of this section.

For engineering or technical information contact your local sales representative or call Distributor Sales (800)523-6572 or Linear Sales (800)462-3399.

DIMENSION TABLE - Dimensions in mm

PART NUMBER	DIMENSIONS										SUITABLE FOR LINEAR RECIRCULATING BALL BEARING AND GUIDEWAY ASSEMBLY
	A	a ₁ ¹⁾	a ₂	H	H ₁	h ₁	h ₂	h ₃	A _{pF} ²⁾	l _{p min} ³⁾	
FBALG KWE 20	63	42	21	30	5.5	23.5	12	23.5	13	2.5	KUE 20
	44	42	21	30	5.5	23.5	12	23.5	13	2.5	KUE 20 H
FBALG KWE 25	70	46.5	24	36	6.5	26	14	26	13	2.5	KUE 25
	48	46.5	24	40	6.5	26	14	26	13	2.5	KUE 25 H
FBALG KWE 30	90	58	29	42	7.5	28	13.5	29	15.5	2.5	KUE 30
	60	58	29	45	7.5	28	13.5	29	15.5	2.5	KUE 30 H
FBALG KWE 35	100	68	35	48	8	31	15.5	32	19	2.5	KUE 35
	70	68	35	55	8	31	15.5	32	19	2.5	KUE 35 H

1) Maximum width of bellows in end gauge.

2) Expansion per pleat.

3) Compression per pleat.

Linear Ball Bearing Units

KUVS SERIES

Guideways

TKVD SERIES

For details on part numbers, descriptive suffixes and various technical references, please refer to front of this section.

For engineering or technical information contact your local sales representative or call Distributor Sales (800)523-6572 or Linear Sales (800)462-3399.

DIMENSION TABLE - Dimensions in mm															
LINEAR RECIRCULATING BALL BEARING UNITS		GUIDEWAYS			DIMENSIONS						MOUNTING DIMENSIONS				
PART NUMBER	MASS kg	PART NUMBER	MASS kg/m	CLOSING PLUGS	H	A	C	h	a	L ³⁾	A ₁	A ₂	A ₃	A ₄	A ₅
KUVS 32	0.025	TKVD 32	2.3	KA 8 TN	11	51.6	47	10	31.8	2,000	9.9	5.5	40.6	18	6.9
KUVS 42	0.085	TKVD 42	5.54	KA 8 TN	19	75	71	18	42	2,000	16.5	10	55	24	9
KUVS 42	0.085	TKVD 14	1.45	KA 8 TN	15	30	71	14	13.5	1,500	16.5	10	16.2	6	-
KUVS 69	0.2	TKVD 69	12.42	KA 11 TN	25	114	96	24	69	2,000	22.5	13	88	40	14.5
KUVS 69	0.2	TKVD 19	2.66	KA 11 TN	20	42	96	19	19.5	2,000	22.5	13	22.2	8	-

- 1) For two linear ball bearing units with TKVD 32, TKVD 42 and TKVD 69 and for one linear ball bearing unit with TKVD 14 and TKVD 19.
- 2) The usable load carrying capacity is influenced by the connections between the guidance elements and the adjacent construction.
- 3) Maximum length L of a single piece guideway; longer guideways are supplied as multi-piece guideways and are marked accordingly.
- 4) Dimensions C₅ and C₆ are dependent on the length of the guideway;
- 5) If there is a possibility of settling, the fixing screws should be secured against rotation.

DIAMETERS AND TIGHTENING TORQUES FOR THREADS AND SCREWS ⁵⁾						
PART NUMBER	K ₁ for screws to DIN 912-12.9		K ₂ for screws to DIN 912-12.9		K ₃ for screws to DIN 912-12.9	
		Nm max.		Nm max.		Nm max.
KUVS 32	M3	2.5	M3	1.5	-	-
KUVS 42	M3	2.5	M4	3	M3	2.5
KUVS 69	M5	10	M6	10	M5	10
KUVS 69	M5	10	M6	10	M5	10

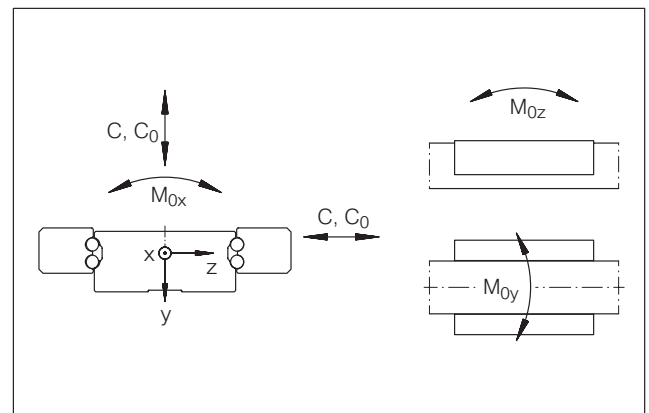

Load directions

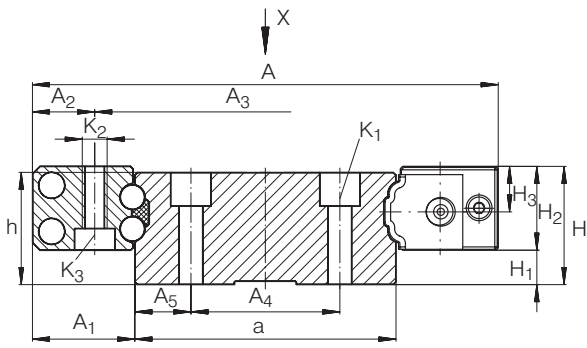

Two KUVS with TKVD 32, TKVD 42 and TKVD 69

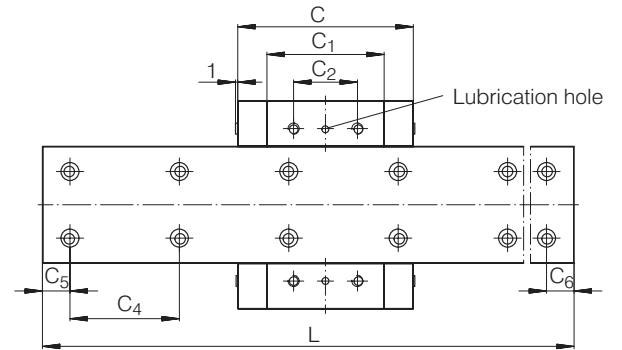

Plan view X (rotated through 90°)

										LOAD CARRYING CAPACITY ¹⁾²⁾				
										BASIC LOAD RATINGS		MOMENT RATINGS		
C ₁	C ₂	C ₄	C ₅ ⁴⁾		C ₆ ⁴⁾		H ₁	H ₂	H ₃	C	C ₀	M _{0x}	M _{0y}	M _{0z}
			min.	max.	min.	max.								
29.8	15	40	5	35	5	35	0.5	10.5	6	5.7	10.6	203	51	51
48.5	20	60	5	55	5	55	5.5	13.5	7.3	13.5	26	648	211	211
48.5	20	60	5	55	5	55	1.5	13.5	7.3	6.75	13	–	–	–
64	35	60	7	53	7	53	7.5	17.5	9.5	26	46.5	1,872	492	492
64	35	60	7	53	7	53	2.5	17.5	9.5	13	23.25	–	–	–

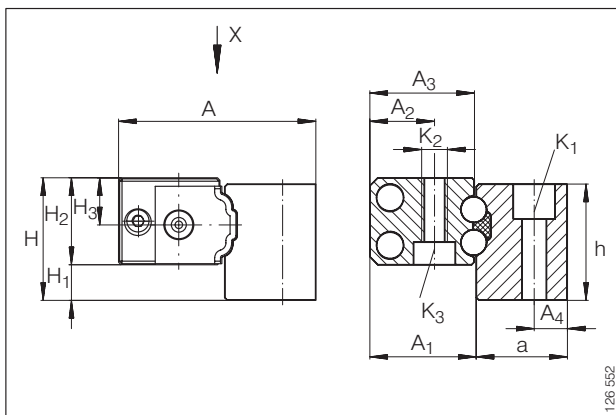

KUVS with TKVD 14, TKVD 19 (end view and cross section)

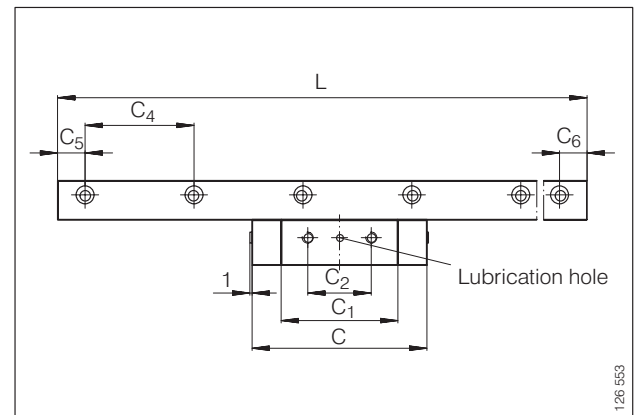

Plan view X (rotated through 90°)

Carriages

KWVK..AL SERIES

Guideways

TKVD SERIES

For details on part numbers, descriptive suffixes and various technical references, please refer to front of this section.

For engineering or technical information contact your local sales representative or call Distributor Sales (800)523-6572 or Linear Sales (800)462-3399.

DIMENSION TABLE - Dimensions in mm																		
CARRIAGES		GUIDEWAYS			DIMENSIONS						MOUNTING DIMENSIONS							
PART NUMBER	MASS	PART NUMBER	MASS	CLOSING PLUGS	H	A	C	h	a	L ²⁾	A ₁	A ₂	A ₃	A ₄	A ₅	A ₆	A ₇	A ₈
	kg		kg/m															
KWVK 32 AL	0.17	TKVD 32	2.3	KA 8 TN	26	62	50	10	31.8	2,000	15.1	10.7	40.6	18	6.9	51.6	-	-
KWVK 42 AL	0.45	TKVD 42	5.54	KA 8 TN	35	87	75	18	42	2,000	22.5	16	55	24	9	75	31	25
KWVK 69 AL	1.1	TKVD 69	12.42	KA 11 TN	47	130	100	24	69	2,000	30.5	21	88	40	14.5	114	42.5	45

- 1) The usable load carrying capacity is influenced by the connections between the guidance elements and the adjacent construction.
- 2) Maximum length L of a single piece guideway; longer guideways are supplied as multi-piece guideways and are marked accordingly.
- 3) Dimensions C₅ and C₆ are dependent on the length of the guideway.
- 4) If there is a possibility of settling, the fixing screws should be secured against rotation.

DIAMETERS AND TIGHTENING TORQUES FOR THREADS AND SCREWS ⁴⁾					
PART NUMBER	K ₁ for screws to DIN 912-12.9		K ₂ for screws to DIN 7984-8.8		K ₄ for screws to DIN 913
		Nm max.		Nm max.	
KWVK 32 AL	M3	2.5	M3	0.6	M3
KWVK 42 AL	M3	2.5	M4	2.1	M4
KWVK 69 AL	M5	10	M6	4.8	M6

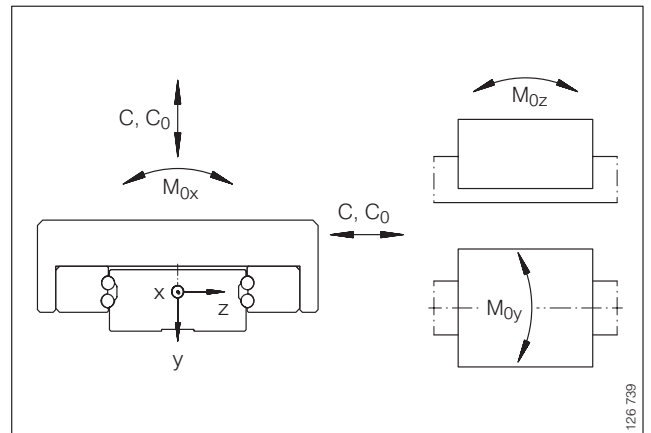

Load directions

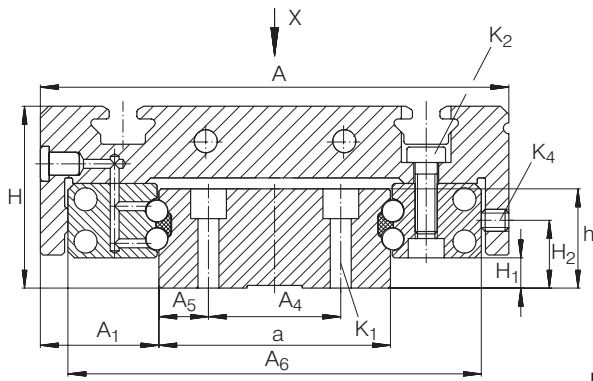

KWK..AL on TKVD

Plan view X
(rotated through 90°)

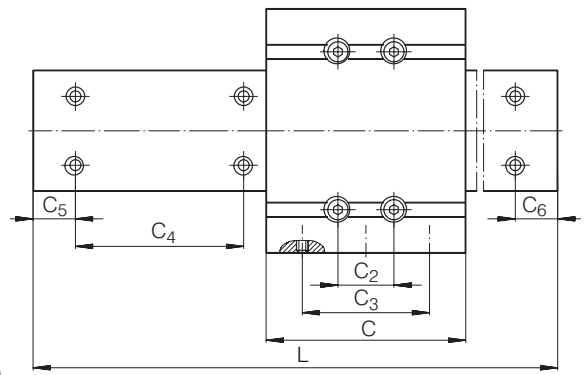

											LOAD CARRYING CAPACITY ¹⁾				
											BASIC LOAD RATINGS		MOMENT RATINGS		
C ₂	C ₃	C ₄	C ₅ ³⁾		C ₆ ³⁾		d	H ₁	H ₂	h ₁	C	C ₀	M _{0x}	M _{0y}	M _{0z}
			min.	max.	min.	max.									
15	25	40	5	35	5	35	4.2	0.5	6	7.5	5.7	10.6	203	51	51
20	40	60	5	55	5	55	4.2	5.5	12	8	13.5	26	648	211	211
35	55	60	7	53	7	53	4.2	7.5	17	11	26	46.5	1872	412	492

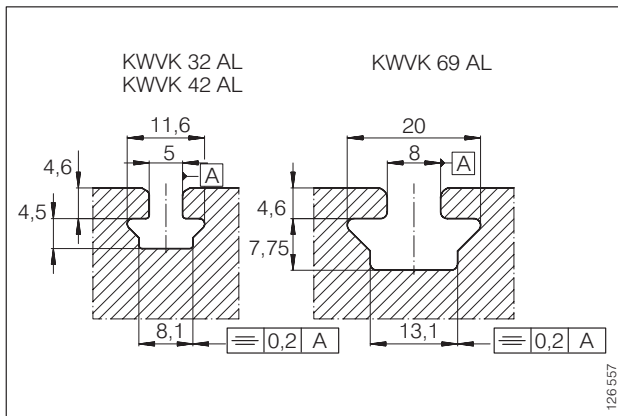

Detail X



KWK 32 AL

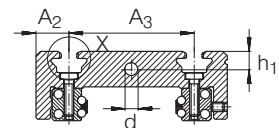

KWK 42 AL

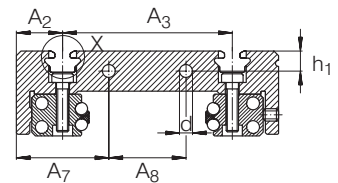

KWK 69 AL

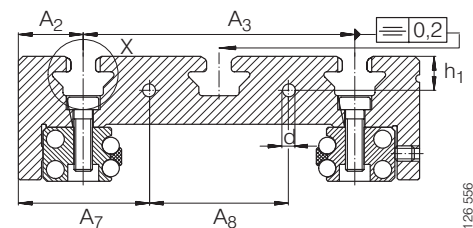

Cross-section of carriages KWK..AL

Miniature Linear Recirculating Ball Bearing And Guideway Assemblies

KUME SERIES

For details on part numbers, descriptive suffixes and various technical references, please refer to front of this section.

For engineering or technical information contact your local sales representative or call Distributor Sales (800)523-6572 or Linear Sales (800)462-3399.

DIMENSION TABLE - Dimensions in mm													
UNIT	CARRIAGE		GUIDEWAY		CLOSING PLUG	DIMENSIONS				MOUNTING DIMENSIONS			
PART NUMBER	PART NUMBER	MASS kg	PART NUMBER	MASS kg/m		L ¹⁾	H	A	C	A ₁	A ₂	a -0.005 -0.05	a ₃
KUME 9	KWME 9	0.016	TKMD 9	0.31	-	280	10	20	29.15	5.5	15	9	2.5
KUME 12	KWME 12	0.036	TKMD 12	0.56	-	470	13	27	34.3	7.5	20	12	3.5
KUME 15	KWME 15	0.06	TKMD 15	1.1	KA 8 TN	1200	16	32	42	8.5	25	15	3.5

- 1) Maximum length L of single piece guideway; longer guideways are supplied as multi-piece guideways and are marked accordingly.
- 2) Dimensions C₅ and C₆ are dependent on the guideway length.
- 3) If there is a possibility of settling, the fixing screws should be secured against rotation.

DIAMETERS AND TIGHTENING TORQUES FOR THREADS AND SCREWS ³⁾				
PART NUMBER	K ₁ for screws to DIN 912-12.9		K ₂ for screws to DIN 912-12.9	
		Nm max.		Nm max.
KUME 9	M2	1	M2	0.5
KUME 12	M3	2.5	M3	1.5
KUME 15	M3	2.5	M3	1.5

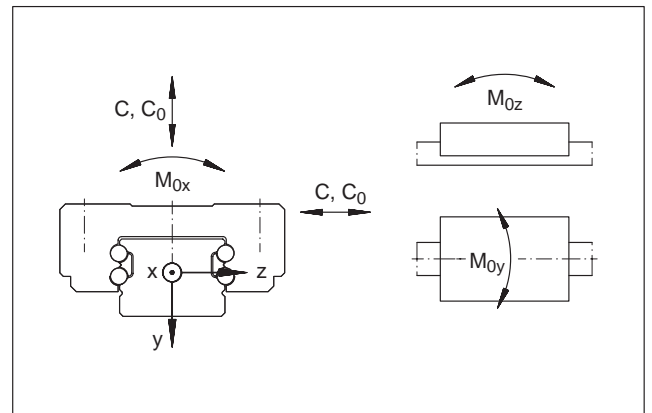

Load directions

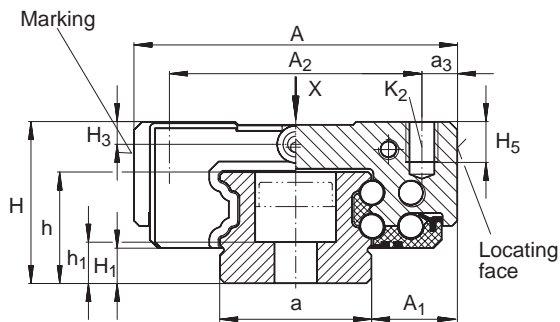

KUME 15

KUME 15, plan view X
(rotated through 90°)

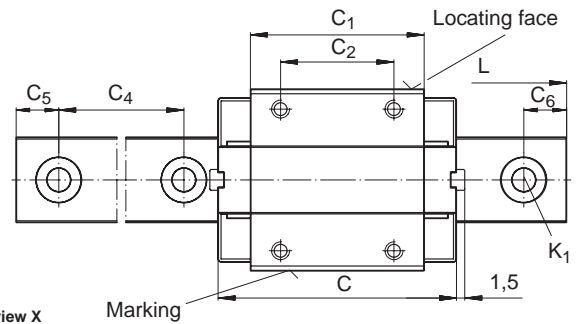

												LOAD CARRYING CAPACITY				
												BASIC LOAD RATINGS		MOMENT RATINGS		
C ₁	C ₂	C ₄	C ₅ ²⁾		C ₆ ²⁾		H ₁	H ₅	h	h ₁	C	C ₀	M _{0x}	M _{0y}	M _{0z}	
			min.	max.	min.	max.										N
18.35	13	20	5	15	5	15	2.25	2.5	5.5	2.5	1,340	2,060	8.8	5.8	5.8	
22	15	25	5	20	5	20	3.05	3.5	7.5	3	2,150	3,200	20.8	11.3	11.3	
30.6	20	40	6	34	6	34	3.5	4.0	11	4.1	3,750	6,800	65	33	33	

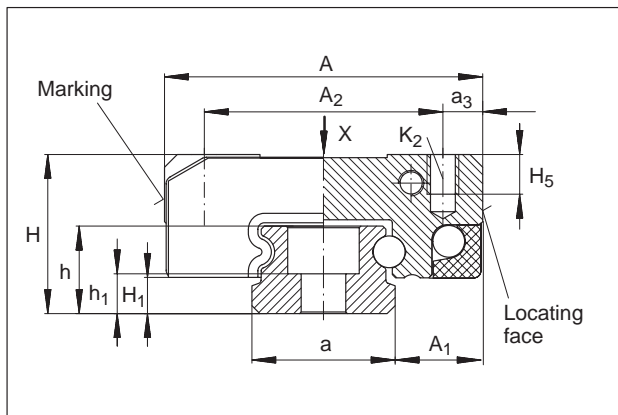

KUME 9, KUME 12

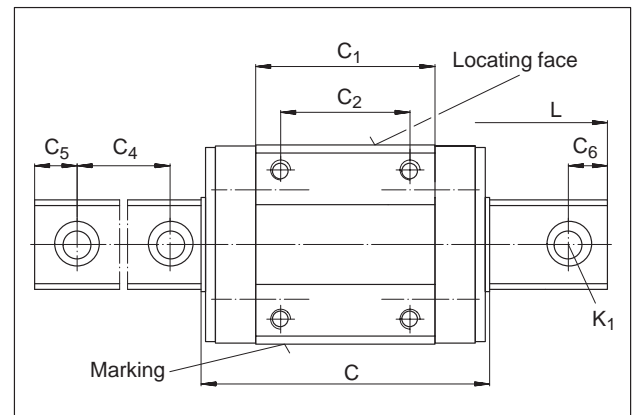

KUME 9, KUME 12, plan view X (rotated through 90°)



Track Roller Linear Guidance Systems With Hollow Section Carriage

LFCL SERIES

And Guideways

LFS,LFS..C,LFS..CE,LFS..N SERIES

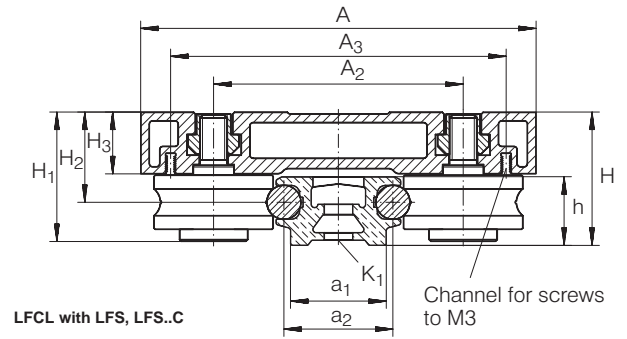

For details on part numbers, descriptive suffixes and various technical references, please refer to front of this section.

For engineering or technical information contact your local sales representative or call Distributor Sales (800)523-6572 or Linear Sales (800)462-3399.

DIMENSION TABLE - Dimensions in mm													
CARRIAGE ¹⁾	MASS ≈g	CONTAINS TRACK ROLLER	GUIDEWAYS	MASS ≈g/m	DIMENSIONS						MOUNTING DIMENSIONS		
					CARRIAGE			GUIDEWAY			A ₁	A ₂	A ₃
					H	A	C	h	a	L ²⁾			
LFCL 25	440	LFR 50/8 KDD	LFS 25	1,100	32	80	110	15	25	2,000	47	47	69
LFCL 25	440	LFR 50/8 KDD	LFS 25 N	1,000	32	80	110	15	25	2,000	47	47	69
LFCL 42	1,000	LFR 5201 KDD	LFS 42 C ¹⁾	2,200	39	116	150	20	42	8,000	73	73	98.5
LFCL 42	1,000	LFR 5201 KDD	LFS 42 CE ¹⁾	2,200	39	116	150	20	42	8,000	73	73	98.5
LFCL 86 ⁷⁾	2,200	LFR 5301 KDD	LFS 86 C ¹⁾	4,400	59	190	235	34	86	8,000	124	124	151.5

Corrosion-resistant executions: LFCL..VA, LFS..VA. Guideway without holes: LFS..OL.

- 1) The shape of the hollow sections is dependent on the size.
- 2) Maximum length of single-piece guideways, longer guideways are supplied as multi-piece guideways and are marked accordingly.
- 3) Dimensions C₅ and C₆ are dependent on the guideway length L.
- 4) For screws to DIN 912-8.8, washers to DIN 433 are required for maximum loading.
- 5) Recommended distance between screws.
- 6) For screws to DIN 931/933-8.8, special washers are included in the delivery.
- 7) Additional T-groove in center of carriage.
- 8) Load carrying capacity table is not valid for LFCL..VA and LFS..VA.

LOAD CARRYING CAPACITY TABLE ⁸⁾											
PART NUMBER	LOADS				MOMENTS						
	F _y max N	F _{0y} max N	F _z max N	F _{0z} max N	M _x max Nm	M _{0x} max Nm	M _y max Nm	M _{0y} max Nm	M _z max Nm	M _{0z} max Nm	
LFCL 25 with LFS 25	850	1,400	1,000	1,000	9	15	26	26	22	36	
LFCL 25 with LFS 25 N	850	1,400	1,000	1,000	9	15	26	26	22	36	
LFCL 42 with LFS 42 C	1,500	2,500	3,000	3,000	27	42	127	127	63	106	
LFCL 42 with LFS 42 CE	1,500	2,500	3,500	3,500	27	42	148	148	63	106	
LFCL 86 with LFS 86 C	2,400	4,000	4,500	4,500	74	124	360	360	192	320	

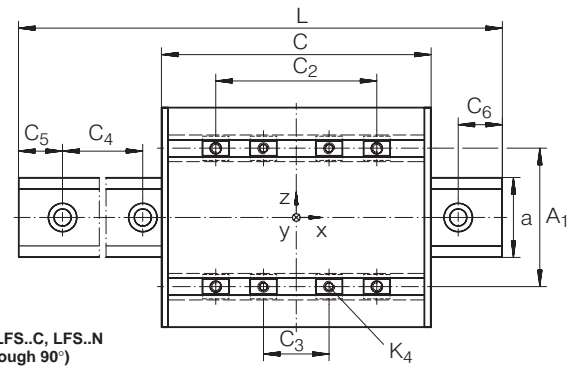
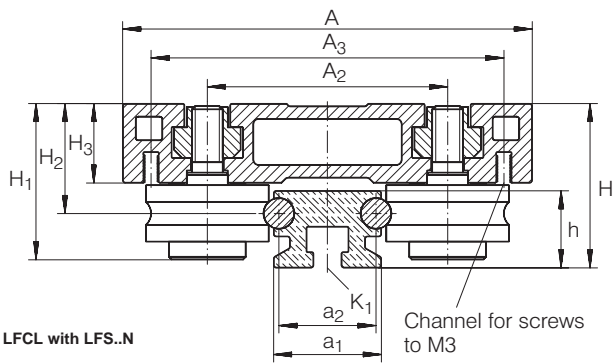

a ₁	a ₂	C ₂	C ₃		C ₄	C ₅ ³⁾		C ₆ ³⁾		H ₁	H ₂	H ₃	K ₁ ⁴⁾	K ₄	MAXIMUM LENGTH OF MOUNTING SCREW FOR K ₄
			min.	max.		min.	max.	min.	max.						
21	19	52	13	26	62.5	10	54	10	54	30.5	21.5	15.4	M5	M6	10
21	19	52	13	26	62.5 ⁵⁾	–	–	–	–	30.5	21.5	15.4	M5 ⁶⁾	M6	10
28	32	85	15	55	125	12	113	12	113	38.1	26.4	18	M8	M8	12
28	32	85	15	55	62.5	12	51	12	51	38.1	26.4	18	M8	M8	12
71	76	155	18	119	250	17	235	17	235	48.4	33.9	23.4	M12	M10	14

Track Roller Linear Guidance Systems With Open Carriage

LFL..SF SERIES

And Guideways

LFS, LFS..C, LFS..CE, LFS..N, LFS..NZZ, LFS..F, LFS..FE SERIES

For details on part numbers, descriptive suffixes and various technical references, please refer to front of this section.

For engineering or technical information contact your local sales representative or call Distributor Sales (800)523-6572 or Linear Sales (800)462-3399.

DIMENSION TABLE - Dimensions in mm															
CARRIAGE	MASS ≈ g	CONTAINS TRACK ROLLER	GUIDEWAYS	MASS ≈ g/m	DIMENSIONS						MOUNTING DIMENSIONS				
					CARRIAGE			GUIDEWAY			A ₁	A ₂	A ₃	a ₁	a ₂
					H	A	C	h	a	L ¹⁾					
LFL 20 SF	160	LFR 50/5 KDD-4	LFS 20	600	22	55	50	12.2	20	2,000	40	34	- ⁸⁾	17	16
LFL 32 SF	400	LFR 50/8 KDD	LFS 32 C	1,100	35.5	80	90	20	32	6,000	59	54	56	24	26
LFL 32 SF	400	LFR 50/8 KDD	LFS 32 CE	1,100	35.5	80	90	20	32	6,000	59	54	56	24	26
LFL 32 SF	400	LFR 50/8 KDD	LFS 32 F	1,000	25.5	80	90	10	32	4,000	59	54	56	-	26
LFL 32 SF	400	LFR 50/8 KDD	LFS 32 N	1,400	35.5	80	90	20	32	6,000	59	54	56	24	26
LFL 52 SF	1,000	LFR 5201 KDD	LFS 52 C	3,000	54.3	120	100	34	52	8,000	90	83	65	40	42
LFL 52 SF	1,000	LFR 5201 KDD	LFS 52 CE	3,000	54.3	120	100	34	52	8,000	90	83	65	40	42
LFL 52 SF	1,000	LFR 5201 KDD	LFS 52 F	3,000	44.2	120	100	18	52	4,000	90	83	65	-	42
LFL 52 SF	1,000	LFR 5201 KDD	LFS 52 NZZ	3,900	54.3	120	100	34	52	8,000	90	83	65	46.5	42
LFL 52 E SF	1,900	LFR 5301 KDD	LFS 52 CE	3,000	60.4	135	150	34	52	8,000	105	90	65	40	42
LFL 52 E SF	1,900	LFR 5301 KDD	LFS 52 FE	3,000	44.2	135	150	18	52	4,000	105	90	65	40	42
LFL 52 SF	1,000	LFR 5201 KDD	LFS 52	4,400	54.3	120	100	34	52	8,000	90	83	65	40	42
LFL 52 SF	1,000	LFR 5201 KDD	LFS 52 E	4,400	54.3	120	100	34	52	8,000	90	83	65	40	42

LOAD CARRYING CAPACITY TABLE ⁷⁾											
PART NUMBER	LOADS				MOMENTS						
	F _y max N	F _{0y} max N	F _z max N	F _{0z} max N	M _x max Nm	M _{0x} max Nm	M _y max Nm	M _{0y} max Nm	M _z max Nm	M _{0z} max Nm	
LFL 20 SF with LFS 20	400	660	700	700	4	6	8.6	8.6	4.8	8	
LFL 32 SF with LFS 32 C	850	1,400	930	930	11	18	27	27	26	43	
LFL 32 SF with LFS 32 CE	850	1,400	1,300	1,300	11	18	39	39	26	43	
LFL 32 SF with LFS 32 F	850	1,400	1,000	1,000	11	18	30	30	26	43	
LFL 32 SF with LFS 32 N	850	1,400	1,000	1,000	11	18	30	30	26	43	
LFL 52 SF with LFS 52 C	1,500	2,500	2,000	2,000	33	52	60	60	47	78	
LFL 52 SF with LFS 52 CE	1,500	2,500	3,500	3,500	33	52	105	105	47	78	
LFL 52 SF with LFS 52 F	1,500	2,500	2,500	2,500	33	52	75	75	47	78	
LFL 52 SF with LFS 52 NZZ	1,500	2,500	2,500	2,500	33	52	75	75	47	78	
LFL 52 E SF with LFS 52 CE	2,400	4,000	4,000	4,000	51	84	208	208	126	210	
LFL 52 E SF with LFS 52 FE	2,400	4,000	4,000	4,000	51	84	208	208	126	210	



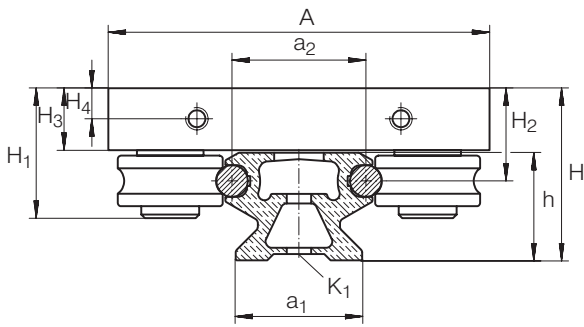

LFL..SF with LFS, LFS..C, LFS..CE

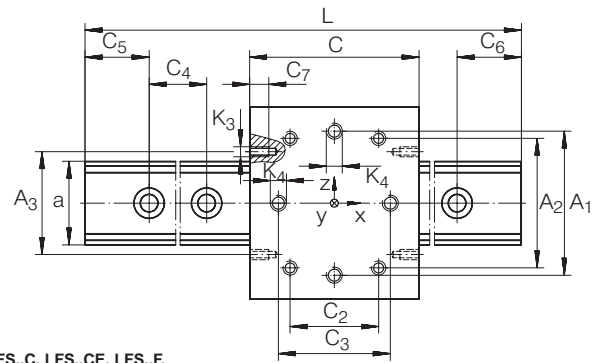

LFL..SF with LFS, LFS..C, LFS..CE, LFS..F,
LFS..FE, LFS..N, LFS..NZZ (view rotated through 90°)

C ₂	C ₃ ±0.2	C ₄	C ₅ ²⁾		C ₆ ²⁾		C ₇	H ₁ max.	H ₂	H ₃	H ₄	K ₁ ³⁾	K ₃	K ₄	M _A ⁴⁾	
			min.	max.	min.	max.									STANDARD Nm	CORROSION- RESISTANT Nm
24	38	62.5	9	54	9	54	—	20.5	13	9	—	M4	M3 ⁸⁾	M5	2.5	2.5
60	70	125	11	116	11	116	7	31.9	20.4	14	7	M6	M6	M8	15	12
60	70	62.5	11	52	11	52	7	31.9	20.4	14	7	M6	M6	M8	15	12
60	70	125	11	116	11	116	7	31.9	20.4	14	7	M6 ⁹⁾	M6	M8	15	12
60	70	125 ⁵⁾	—	—	—	—	7	31.9	20.4	14	7	M6 ⁶⁾	M6	M8	15	12
60	70	250	17	235	17	235	12	46.3	29.2	19.5	9.75	M10	M6	M10	40	23
60	70	125	17	110	17	110	12	46.3	29.2	19.5	9.75	M10	M6	M10	40	23
60	70	250	17	235	17	235	12	46.3	29.2	19.5	9.75	M10 ⁹⁾	M6	M10	40	23
60	70	250 ⁵⁾	—	—	—	—	12	46.3	29.2	19.5	9.75	M10 ⁶⁾	M6	M10	40	23
105	110	125	17	110	17	110	12	53.7	35.2	24	12	M10	M6	M10	40	23
105	110	125	17	110	17	110	12	53.7	35.2	24	12	M10	M6	M10	40	23
60	70	250	17	235	17	235	12	53.5	29.2	19.5	9.75	M10	M6	M10	40	23
60	70	125	17	110	17	110	12	53.5	29.2	19.5	9.75	M10	M6	M10	40	23

Corrosion-resistant executions: LFL..VA, LFS..VA. Guideway without holes: LFS..OL.

- Maximum length of single-piece guideways, longer guideways are supplied as multi-piece guideways and are marked accordingly.
- Dimensions C₅ and C₆ are dependent on the guideway length L.
- For screws to DIN 912-8.8, washers to DIN 433 are required for maximum loading.
- Tightening torque for LFZ and LFE, bolts LFZ are supplied tightened to M_A.
- Recommended distance between screws.
- For screws to DIN 931/933-8.8, special washers are included in the delivery.
- Load carrying capacity table is not valid for LFL..VA and LFS..VA.
- Holes for mounting from below for AB LFL 20.
- Countersink depth for screws to DIN 6 912.

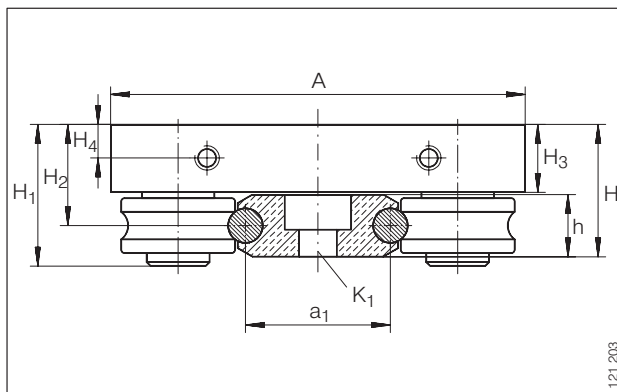

LFL..SF with LFS..F, LFS..FE

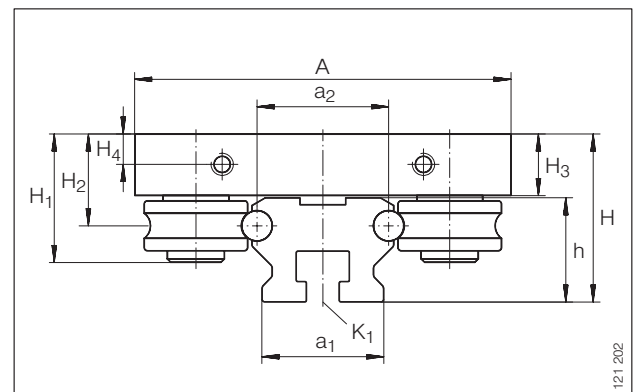

LFL..SF with LFS..N, LFS..NZZ

Track Roller Linear Guidance Systems With Compact Carriage

LFKL..SF SERIES

And Guideways

LFS, LFS..C, LFS..CE, LFS..CEE, LFS..F, LFS..FE, LFS..N, LFS..NZZ SERIES

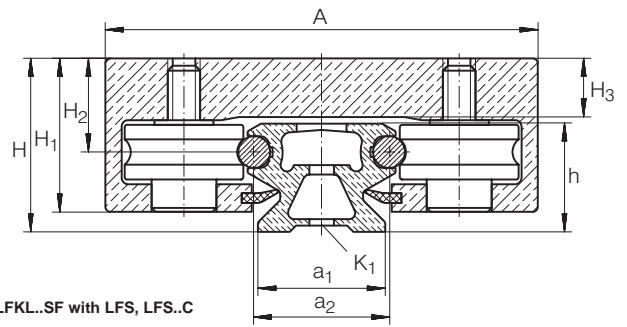

For details on part numbers, descriptive suffixes and various technical references, please refer to front of this section.

For engineering or technical information contact your local sales representative or call Distributor Sales (800)523-6572 or Linear Sales (800)462-3399.

DIMENSION TABLE - Dimensions in mm

CARRIAGE	MASS ≈ g	CONTAINS TRACK ROLLER	GUIDEWAYS	MASS ≈ g/m	DIMENSIONS						MOUNTING DIMENSIONS			
					CARRIAGE			GUIDEWAY			A ₁	A ₂	a ₁	a ₂
					H	A	C	h	a	L ¹⁾				
LFKL 20 SF ⁵⁾	200	LFR 50/5 KDD-4	LFS 20	600	22	56	69	12.2	20	2,000	39	34	17	16
LFKL 25 SF ⁵⁾	300	LFR 50/5 KDD	LFS 25	1,100	25	65	85	15	25	2,000	50	40	21	19
LFKL 25 SF ⁵⁾	300	LFR 50/5 KDD	LFS 25 N	1,000	25	65	85	15	25	2,000	50	40	21	19
LFKL 32 SF	700	LFR 50/8 KDD	LFS 32 C	1,100	35.5	86	112	20	32	6,000	59	54	24	26
LFKL 32 SF	700	LFR 50/8 KDD	LFS 32 CE	1,100	35.5	86	112	20	32	6,000	59	54	24	26
LFKL 32 SF	700	LFR 50/8 KDD	LFS 32 F	1,000	25.5	86	112	10	32	4,000	59	54	-	26
LFKL 32 SF	700	LFR 50/8 KDD	LFS 32 N	1,400	35.5	86	112	20	32	6,000	59	54	24	26
LFKL 52 SF	1,500	LFR 5201 KDD	LFS 52 C	3,000	54.3	130	136	34	52	8,000	90	83	40	42
LFKL 52 SF	1,500	LFR 5201 KDD	LFS 52 CE	3,000	54.3	130	136	34	52	8,000	90	83	40	42
LFKL 52 SF	1,500	LFR 5201 KDD	LFS 52 F	3,000	38.2	130	136	18	52	4,000	90	83	-	42
LFKL 52 SF	1,500	LFR 5201 KDD	LFS 52 NZZ	3,900	54.3	130	136	34	52	8,000	90	83	46.5	42
LFKL 52 E SF	2,900	LFR 5301 KDD	LFS 52 CE	3,000	60.4	145	186	34	52	8,000	105	90	40	42
LFKL 52 E SF	2,900	LFR 5301 KDD	LFS 52 FE	3,000	38.2	145	186	18	52	4,000	105	90	-	42
LFKL 52 EE SF	3,900	LFR 5302 KDD	LFS 52 CEE	4,300	60.4	155	205	34	52	8,000	115	95.3	40	42

LOAD CARRYING CAPACITY TABLE⁸⁾

PART NUMBER	LOADS				MOMENTS					
	F _y max N	F _{0y} max N	F _z max N	F _{0z} max N	M _x max Nm	M _{0x} max Nm	M _y max Nm	M _{0y} max Nm	M _z max Nm	M _{0z} max Nm
LFKL 20 SF with LFS 20	400	660	700	700	4	6	12	12	6.8	11.4
LFKL 25 SF with LFS 25	400	660	700	700	4	6	16	16	9	15
LFKL 25 SF with LFS 25 N	400	660	700	700	4	6	16	16	9	15
LFKL 32 SF with LFS 32 C	850	1,400	930	930	11	18	27	27	26	43
LFKL 32 SF with LFS 32 CE	850	1,400	1,300	1,300	11	18	39	39	26	43
LFKL 32 SF with LFS 32 F	850	1,400	1,000	1,000	11	18	30	30	26	43
LFKL 32 SF with LFS 32 N	850	1,400	1,000	1,000	11	18	30	30	26	43
LFKL 52 SF with LFS 52 C	1,500	2,500	2,000	2,000	33	52	60	60	47	78
LFKL 52 SF with LFS 52 CE	1,500	2,500	3,500	3,500	33	52	105	105	47	78
LFKL 52 SF with LFS 52 F	1,500	2,500	2,500	2,500	33	52	75	75	47	78
LFKL 52 SF with LFS 52 NZZ	1,500	2,500	2,500	2,500	33	52	75	75	47	78
LFKL 52 E SF with LFS 52 CE	2,400	4,000	4,000	4,000	51	84	208	208	126	210
LFKL 52 E SF with LFS 52 FE	2,400	4,000	4,500	4,500	51	84	236	236	126	210
LFKL 52 EE SF with LFS 52 CEE	4,800	8,000	6,500	6,500	101	166	390	390	288	480

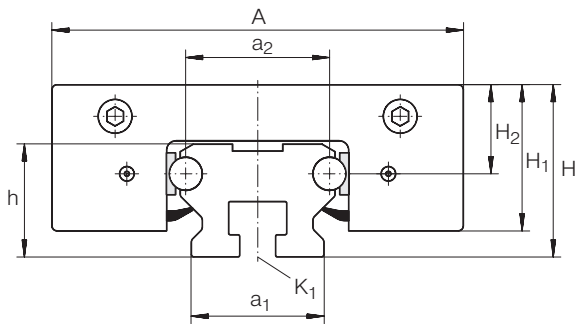

LFKL..SF with LFS..N

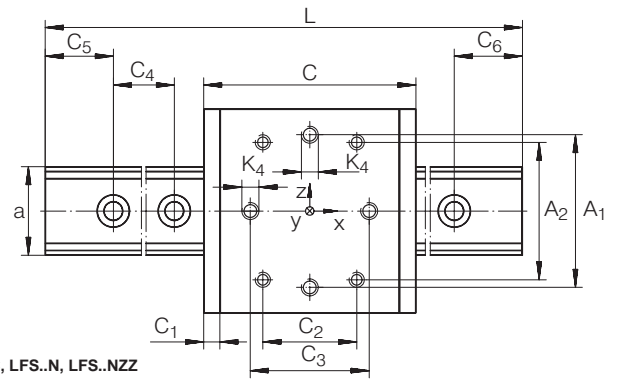

LFKL..SF with LFS, LFS..C, LFS..N, LFS..NZZ
(view rotated through 90°)

C ₁	C ₂	C ₃	C ₄	C ₅ ²⁾		C ₆ ³⁾		H ₁	H ₂	H ₃	K ₁ ³⁾	K ₄	M _A ⁴⁾	
				min.	max.	min.	max.						STANDARD Nm	CORROSION- RESISTANT Nm
5	34	49	62.5	9	54	9	54	20.5	13	8.7	M4	M5	2.5	2.5
5	45	60	62.5	10	54	10	54	23.5	14.4	9	M5	M5	2.5	2.5
5	45	60	62.5 ⁶⁾	—	—	—	—	23.5	14.4	9	M5 ⁷⁾	M5	2.5	2.5
7	60	70	125	11	116	11	116	32	20.5	14	M6	M8	15	12
7	60	70	62.5	11	52	11	52	32	20.5	14	M6	M8	15	12
7	60	70	125	11	116	11	116	32	20.5	14	M6 ⁸⁾	M8	15	12
7	60	70	125 ⁶⁾	—	—	—	—	32	20.5	14	M6 ⁷⁾	M8	15	12
10	60	70	250	17	235	17	235	46.1	29.2	19.4	M10	M10	40	23
10	60	70	125	17	110	17	110	46.1	29.2	19.4	M10	M10	40	23
10	60	70	250	17	235	17	235	46.1	29.2	19.4	M10	M10	40	23
10	60	70	250 ⁶⁾	—	—	—	—	46.1	29.2	19.4	M10 ⁷⁾	M10	40	23
10	105	110	125	17	110	17	110	53.8	35.3	24	M10	M10	40	23
10	105	110	125	17	110	17	110	53.8	35.3	24	M10 ⁸⁾	M10	40	23
10	120	140	62.5	17	49	17	49	55	35.3	24	M10	M12	70	39

Corrosion-resistant executions: LFKL..VA, LFS..VA.
Guideway without holes: LFS..OL.

- 1) Maximum length of single-piece guideways, longer guideways are supplied as multi-piece guideways and are marked accordingly.
- 2) Dimensions C₅ and C₆ are dependent on the guideway length L.
- 3) For screws to DIN 912-8.8, washers to DIN 433 are required for maximum loading; for guideways LFS..F and LFS..FE, countersink depth for screws to DIN 6 912.
- 4) Tightening torque for track roller bolts, concentric bolts supplied tightened to M_A.
- 5) Without lubricating nipples, relubrication possible via end face holes.
- 6) Recommended distance between screws.
- 7) For screws to DIN 931/933-8.8, special washers are included in the delivery.
- 8) Load carrying capacity table is not valid for LFKL..VA and LFS..VA.

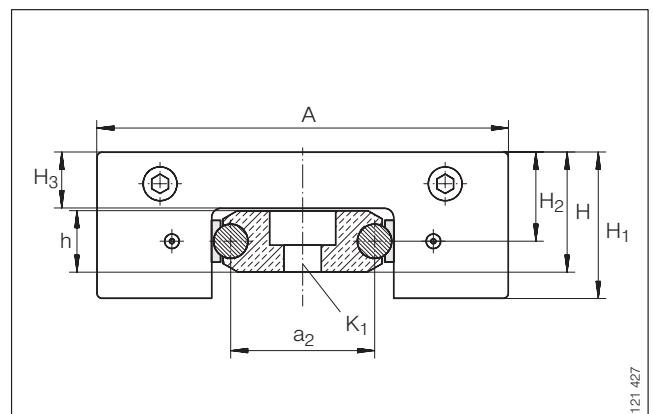

LFKL..SF with LFS..F



Track Roller Linear Guidance Systems With Bogie Carriage

LFDL SERIES

And Guideways

LFS..R SERIES

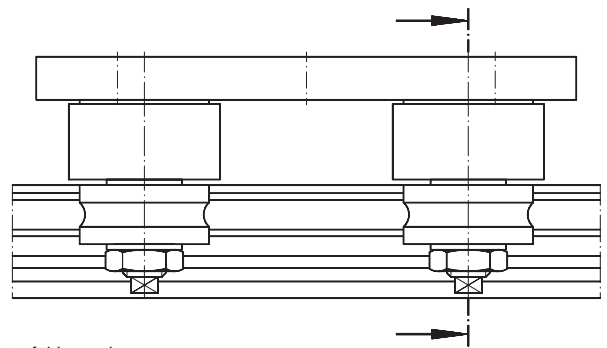

LFDL with LFS..R

For details on part numbers, descriptive suffixes and various technical references, please refer to front of this section.

For engineering or technical information contact your local sales representative or call Distributor Sales (800)523-6572 or Linear Sales (800)462-3399.

DIMENSION TABLE - Dimensions in mm

CARRIAGE	MASS ≈ g	CONTAINS TRACK ROLLER	GUIDEWAYS CURVED ELEMENT	MASS ≈ g	DIMENSIONS					
					CARRIAGE			GUIDEWAY		
					H	A	C	h	a	β
LFDL 32	1,500	LFR 50/8 KDD	LFS 32 R-100/ 90	500	43.5	80	100	20	32	90●
LFDL 32	1,500	LFR 50/8 KDD	LFS 32 R-100/180	1,000	43.5	80	100	20	32	180●
LFDL 32	1,500	LFR 50/8 KDD	LFS 32 R-100/360	2,000	43.5	80	100	20	32	360●
LFDL 32	1,500	LFR 50/8 KDD	LFS 32 R-300/ 90	1,700	43.5	80	100	20	32	90●
LFDL 32	1,500	LFR 50/8 KDD	LFS 32 R-300/180	3,400	43.5	80	100	20	32	180●
LFDL 32	1,500	LFR 50/8 KDD	LFS 32 R-300/360	6,800	43.5	80	100	20	32	360●
LFDL 32	1,500	LFR 50/8 KDD	LFS 32 R-500/ 90	2,900	43.5	80	100	20	32	90●
LFDL 32	1 500	LFR 50/8 KDD	LFS 32 R-500/180	5,800	43.5	80	100	20	32	180●
LFDL 32	1 500	LFR 50/8 KDD	LFS 32 R-500/360	11,600	43.5	80	100	20	32	360●
LFDL 52	1,500	LFR 5201 KDD	LFS 52 R-150/ 90	2,000	66.1	120	150	34	52	90●
LFDL 52	2,500	LFR 5201 KDD	LFS 52 R-150/180	4,000	66.1	120	150	34	52	180●
LFDL 52	2,500	LFR 5201 KDD	LFS 52 R-150/360	8,000	66.1	120	150	34	52	360●
LFDL 52	2,500	LFR 5201 KDD	LFS 52 R-300/ 90	4,500	66.1	120	150	34	52	90●
LFDL 52	2,500	LFR 5201 KDD	LFS 52 R-300/180	9,000	66.1	120	150	34	52	180●
LFDL 52	2,500	LFR 5201 KDD	LFS 52 R-300/360	18,000	66.1	120	150	34	52	360●
LFDL 52	2,500	LFR 5201 KDD	LFS 52 R-500/ 90	7,800	66.1	120	150	34	52	90●
LFDL 52	2,500	LFR 5201 KDD	LFS 52 R-500/180	15,600	66.1	120	150	34	52	180●
LFDL 52	2,500	LFR 5201 KDD	LFS 52 R-500/360	31,200	66.1	120	150	34	52	360●

Corrosion-resistant executions: LFDL..VA, LFS..R VA. Guideway without holes: LFS..R OL.

- 1) For screws to DIN 912-8.8.
- 2) Number of holes on reference circle r_1 .
- 3) Tightening torque for bolts LFZ and LFE, bolts LFZ are supplied tightened to M_A .

LOAD CARRYING CAPACITY TABLE

PART NUMBER	LOADS				MOMENTS					
	F_y max N	F_{0y} max N	F_z max N	F_{0z} max N	M_x max Nm	M_{0x} max Nm	M_y max Nm	M_{0y} max Nm	M_z max Nm	M_{0z} max Nm
LFDL 32 with LFS 32 R-100/ 90	850	1,400	1,000	1,000	11	18	13	13	11	18
LFDL 32 with LFS 32 R-100/180	850	1,400	1,000	1,000	11	18	13	13	11	18
LFDL 32 with LFS 32 R-300/ 90	850	1,400	1,000	1,000	11	18	13	13	11	18
LFDL 32 with LFS 32 R-300/180	850	1,400	1,000	1,000	11	18	13	13	11	18
LFDL 32 with LFS 32 R-500/ 90	850	1,400	1,000	1,000	11	18	13	13	11	18
LFDL 32 with LFS 32 R-500/180	850	1,400	1,000	1,000	11	18	13	13	11	18
LFDL 52 with LFS 52 R-150/ 90	1,500	2,500	2,500	2,500	31	31	41	41	25	25
LFDL 52 with LFS 52 R-150/180	1,500	2,500	2,500	2,500	31	31	41	41	25	25
LFDL 52 with LFS 52 R-300/ 90	1,500	2,500	2,500	2,500	31	31	41	41	25	25
LFDL 52 with LFS 52 R-300/180	1,500	2,500	2,500	2,500	31	31	41	41	25	25
LFDL 52 with LFS 52 R-500/ 90	1,500	2,500	2,500	2,500	31	31	41	41	25	25
LFDL 52 with LFS 52 R-500/180	1,500	2,500	2,500	2,500	31	31	41	41	25	25



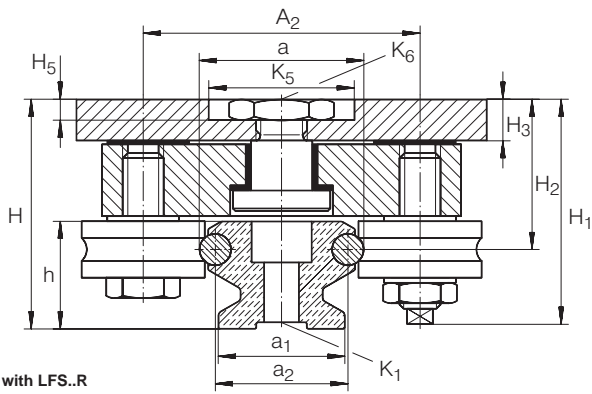

LFDL with LFS..R

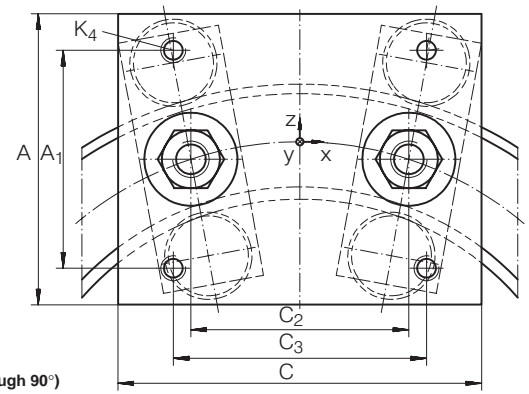

LFDL with LFS..R
(view rotated through 90°)

MOUNTING DIMENSIONS

A ₁	A ₂	a ₁	a ₂	C ₂	C ₃	H ₁	H ₂	H ₃	H ₅	K ₁ ¹⁾	K ₄	K ₅	K ₆	x ²⁾	r ₁	α	α/2	M _A ³⁾	
																		STANDARD Nm	CORROSION RESISTANT Nm
60	54	24	26	60	70	43	29.2	9	5	M6	M8	30	M10	3	84	30	15	15	12
60	54	24	26	60	70	43	29.2	9	5	M6	M8	30	M10	6	84	30	15	15	12
60	54	24	26	60	70	43	29.2	9	5	M6	M8	30	M10	12	84	30	–	15	12
60	54	24	26	60	70	43	29.2	9	5	M6	M8	30	M10	4	284	22.5	11.25	15	12
60	54	24	26	60	70	43	29.2	9	5	M6	M8	30	M10	8	284	22.5	11.25	15	12
60	54	24	26	60	70	43	29.2	9	5	M6	M8	30	M10	12	284	22.5	–	15	12
60	54	24	26	60	70	43	29.2	9	5	M6	M8	30	M10	5	484	18	9	15	12
60	54	24	26	60	70	43	29.2	9	5	M6	M8	30	M10	10	484	18	9	15	12
60	54	24	26	60	70	43	29.2	9	5	M6	M8	30	M10	12	484	18	–	15	12
90	83	40	42	76	90	65.3	41	11	6	M10	M10	34	M12	3	124	30	15	40	23
90	83	40	42	76	90	65.3	41	11	6	M10	M10	34	M12	6	124	30	15	40	23
90	83	40	42	76	90	65.3	41	11	6	M10	M10	34	M12	12	124	30	–	40	23
90	83	40	42	76	90	65.3	41	11	6	M10	M10	34	M12	4	274	22.5	11.25	40	23
90	83	40	42	76	90	65.3	41	11	6	M10	M10	34	M12	8	274	22.5	11.25	40	23
90	83	40	42	76	90	65.3	41	11	6	M10	M10	34	M12	12	274	22.5	–	40	23
90	83	40	42	76	90	65.3	41	11	6	M10	M10	34	M12	5	474	18	9	40	23
90	83	40	42	76	90	65.3	41	11	6	M10	M10	34	M12	10	474	18	9	40	23
90	83	40	42	76	90	65.3	41	11	6	M10	M10	34	M12	12	474	18	–	40	23

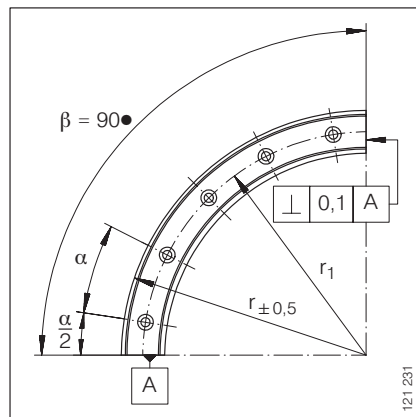

LFS..R../90

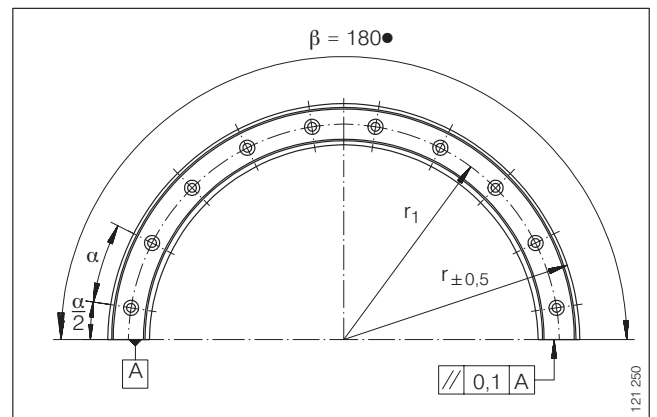

LFS..R../180

Track Rollers

LFR SERIES

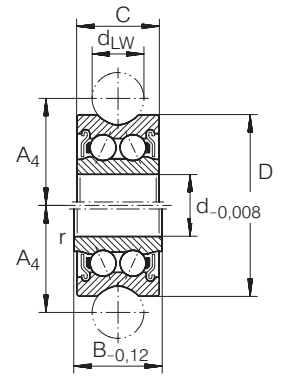

For details on part numbers, descriptive suffixes and various technical references, please refer to front of this section.

For engineering or technical information contact your local sales representative or call Distributor Sales (800)523-6572 or Linear Sales (800)462-3399.

DIMENSION TABLE – TRACK ROLLER · Dimensions in mm

PART NUMBER	MASS \approx g	DIMENSIONS								BASIC LOAD RATINGS			
		A ₄	B	C	D	d	d _{LW}	r to DIN 620	AS TRACK ROLLER				
									dyn. C _w (10 ⁵ m) N	stat. C _{0w} N	F _{rperm} N	F _{0rperm} N	
LFR 50/5 KDD-4	10	9	8	7	16	5	4	0.2	1,200	860	1,300	1,780	
LFR 50/5 KDD	10	10.5	8	7	17	5	6	0.2	1,270	890	1,300	1,780	
LFR 50/8 KDD	20	14	–	11	24	8	6	0.3	3,670	2,280	1,300	4,560	
LFR 5201 KDD	80	20.65	–	15.9	35	12	10	0.6	8,500	5,100	5,100	10,200	
LFR 5301 KDD	100	24	–	19	42	12	10	0.6	13,000	7,700	7,500	14,200	
LFR 5201-12 KDD	80	21.75	–	15.9	35	12	12	0.6	8,400	5,000	5,100	10,000	
LFR 5302 KDD	170	26.65	–	19	47	15	10	1	16,200	9,200	6,200	18,400	
LFR 5204-16 KDD	230	31.5	22.6	20.6	52	20	16	1	16,800	9,500	12,100	16,600	
LFR 5206-20 KDD	250	41	25.8	23.8	72	25	20	1	24,500	16,600	20,700	33,200	
LFR 5206-25 KDD	250	43.5	25.8	23.8	72	25	25	1	29,200	16,400	23,100	32,800	
LFR 5207-30 KDD	660	51	29	27	80	30	30	1	38,000	20,800	21,400	36,200	
LFR 5208-40 KDD	1,360	62.5	38	36	98	40	40	1.1	54,800	29,000	55,000	58,000	

Track rollers LFR with an outside diameter of 52 mm or greater can be relubricated through the inner ring.

Track rollers in corrosion-resistant execution:
LFR..NPP VA.

1) Available on request.

Bolts

LFZ SERIES

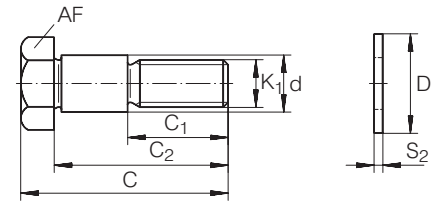

For details on part numbers, descriptive suffixes and various technical references, please refer to front of this section.

For engineering or technical information contact your local sales representative or call Distributor Sales (800)523-6572 or Linear Sales (800)462-3399.

DIMENSION TABLE – CONCENTRIC BOLTS · Dimensions in mm										
PART NUMBER	MASS ≈ g	DIMENSIONS								SUITABLE FOR TRACK ROLLER
		C	C ₁	C ₂	D	d	K ₁	S ₂	AF	
LFZ 5 ¹⁾	10	19.5	9.5	16	- ¹⁾	5	M4	- ¹⁾	3 ²⁾	LFR 50/5..-4
LFZ 5 ¹⁾	10	19.5	9.5	16	- ¹⁾	5	M4	- ¹⁾	3 ²⁾	LFR 50/5
LFZ 8	20	28.3	14	24.3	14	8	M8	1	13	LFR 50/8
LFZ 12	40	43	22	36	21	12	M10	1.8	17	LFR 5201
LFZ 12/M12	60	50.8	24	43.8	19	12	M12	1.8	17	LFR 5301
LFZ 15	60	50.8	26	43.8	21	15	M12	1.8	19	LFR 5302

Concentric bolts in corrosion-resistant execution: LFZ..VA.

Washers included in the delivery.

1) No washers required.

2) Hexagonal socket. Outside diameter of head 10 mm.

Bolts

LFE SERIES

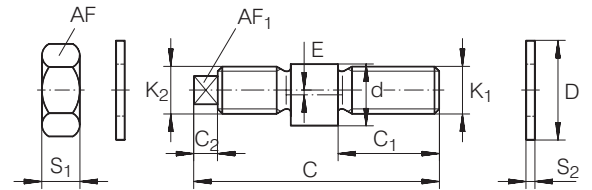

For details on part numbers, descriptive suffixes and various technical references, please refer to front of this section.

For engineering or technical information contact your local sales representative or call Distributor Sales (800)523-6572 or Linear Sales (800)462-3399.

DIMENSION TABLE – ECCENTRIC BOLTS · Dimensions in mm														
PART NUMBER	MASS ≈ g	DIMENSIONS												SUITABLE FOR TRACK ROLLER
		C	C ₂	C ₁	D	d	E	K ₁	K ₂	S ₁	S ₂	AF	AF ₁	
LFE 5-0.5 ¹⁾	10	20.5	–	9	– ¹⁾	5	0.5	M4	M4	2.9	– ¹⁾	7	2 ²⁾	LFR 50/5...-4
LFE 5-0.5 ¹⁾	10	20.5	–	9	– ¹⁾	5	0.5	M4	M4	2.9	– ¹⁾	7	2 ²⁾	LFR 50/5
LFE 8-1	20	33.2	3.5	13.7	14	8	1	M8	M8 × 0.75	4	1	13	5	LFR 50/8
LFE 12-1	40	50	5	19.5	21	12	1	M10	M10	8	1.8	17	6	LFR 5201
LFE 12-1/M12	60	57	5	24	19	12	1	M12	M12	6.5	1.8	17	6	LFR 5301
LFE 15-1	60	57	5	24	21	15	1	M12	M12	6.5	1.8	19	6	LFR 5302

Eccentric bolts in corrosion-resistant execution: LFE..VA.

The nut and washer are included in the delivery.

- 1) No washers required.
- 2) Hexagonal socket.

Bolts

LFZ..A1, LFE..A1 SERIES

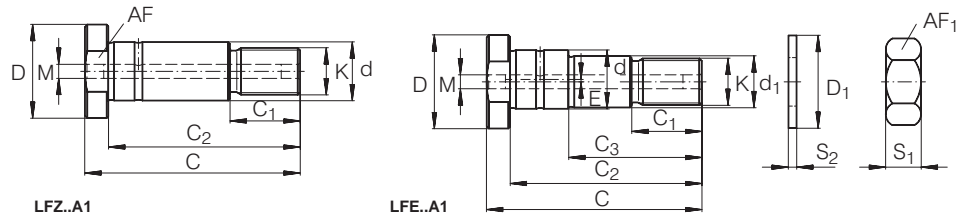

For details on part numbers, descriptive suffixes and various technical references, please refer to front of this section.

For engineering or technical information contact your local sales representative or call Distributor Sales (800)523-6572 or Linear Sales (800)462-3399.

DIMENSION TABLE - Dimensions in mm																	
PART NUMBER	MASS g	DIMENSIONS														SUITABLE FOR TRACK ROLLER	
		d	C	C ₁	C ₂	C ₃	D	D ₁	d ₁ h9	E	K	M	S ₁	S ₂	AF		AF ₁
LFZ 12 × 45 A1	40	12	50	16	45	—	20	21	—	—	M10 × 1.5	—	8	2	17	17	LFR 5201-12 KDD
LFE 12 × 45 A1	40	12	50	16	45	30	20	21	10	0.75	M10 × 1.5	—	8	2	17	17	LFR 5201-12 KDD
LFZ 20 × 67 A1	200	20	75	23	67	—	30	30	—	—	M16 × 1.5	5.9	13	3	27	24	LFR 5204-16 KDD
LFE 20 × 67 A1	200	20	75	23	67	45	30	30	17	1	M16 × 1.5	5.9	13	3	27	24	LFR 5204-16 KDD
LFZ 25 × 82 A1	400	25	92	30	82	—	40	37	—	—	M20 × 1.5	5.9	16	3	36	30	LFR 5206-20, 25 KDD
LFE 25 × 82 A1	400	25	92	30	82	57	40	37	22	1	M20 × 1.5	5.9	16	3	36	30	LFR 5206-20 25 KDD
LFZ 30 × 95 A1	620	30	107	32	95	—	45	44	—	—	M24 × 1.5	5.9	19	4	41	36	LFR 5207-30 KDD
LFE 30 × 95 A1	620	30	107	32	95	67	45	44	27	1	M24 × 1.5	5.9	19	4	41	36	LFR 5207-30 KDD
LFZ 40 × 107 A1	1,100	40	117	42	107	—	55	56	36	—	M30 × 1.5	5.9	24	4	46	46	LFR 5208-40
LFE 40 × 107 A1	1,100	40	117	42	107	72	55	56	36	1	M30 × 1.5	5.9	24	4	46	46	LFR 5208-40

Bolts LFZ 40..A1 and LFE 40..A1 suitable for track roller LFR 5208 are available on request.

Bolts in corrosion-resistant execution: suffix VA.

The nut and washer are included in the delivery.

Guideways

LFS, LFS..C.,LFS..F. SERIES

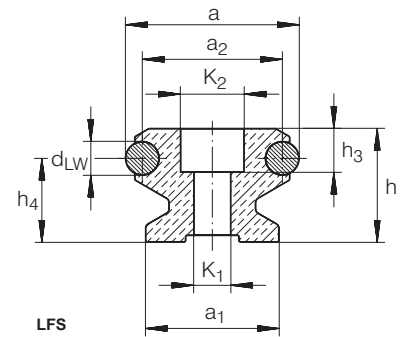

For details on part numbers, descriptive suffixes and various technical references, please refer to front of this section.

For engineering or technical information contact your local sales representative or call Distributor Sales (800)523-6572 or Linear Sales (800)462-3399.

DIMENSION TABLE - Dimensions in mm												
PART NUMBER	MASS ≈ g/m	DIMENSIONS			MOUNTING DIMENSIONS							
		a	h	L ¹⁾	a ₁	a ₂	C ₄	C ₅ ²⁾		C ₆ ²⁾		d _{LW}
								min.	max.	min.	max.	
LFS 20	600	20	12.2	2,000	17	16	62.5	9	54	9	54	4
LFS 25	1,100	25	15	2,000	21	19	62.5	10	54	10	54	6
LFS 32	1,600	32	20	6,000	24	26	125	11	116	11	116	6
LFS 32 E	1,600	32	20	6,000	24	26	62.5	11	52	11	52	6
LFS 32 C ⁴⁾	1,100	32	20	6,000	24	26	125	11	116	11	116	6
LFS 32 CE ⁴⁾	1,100	32	20	6,000	24	26	62.5	11	52	11	52	6
LFS 32 F	1,000	32	10	4,000	–	26	125	11	116	11	116	6
LFS 42 C ⁴⁾	2,200	42	20	8,000	28	32	125	12	113	12	113	10
LFS 42 CE ⁴⁾	2,200	42	20	8,000	28	32	62.5	12	51	12	51	10
LFS 42 F	1,000	42	15	4,000	–	32	125	12	51	12	51	10
LFS 52	4,400	52	34	8,000	40	42	250	17	235	17	235	10
LFS 52 E	4,400	52	34	8,000	40	42	125	17	110	17	110	10
LFS 52 EE	4,400	52	34	8,000	40	42	62.5	17	49	17	49	10
LFS 52 C ⁴⁾	3,000	52	34	8,000	40	42	250	17	235	17	235	10
LFS 52 CE ⁴⁾	3,000	52	34	8,000	40	42	125	17	110	17	110	10
LFS 52 CEE ⁴⁾	3,000	52	34	8,000	40	42	62.5	17	49	17	49	10
LFS 52 F	3,000	52	18	4,000	–	42	250	17	235	17	235	10
LFS 52 FE	3,000	52	18	4,000	–	42	125	17	110	17	110	10
LFS 86 C ⁴⁾	4,400	86	34	8,000	71	76	250	17	235	17	235	10
LFS 86 CE ⁴⁾	4,400	86	34	8,000	71	76	125	17	110	17	110	10

Guideway in corrosion-resistant execution: LFS..VA.

Guideways LFS, LFS..C and LFS..F available without holes: LFS..OL, LFS..C OL, LFS..F OL.

- 1) Maximum length of single-piece guideways, longer guideways are supplied as multi-piece guideways and are marked accordingly.
- 2) Dimensions C₅ and C₆ are dependent on the guideway length L.
- 3) For maximum loading F_z or F_{0z}, washers to DIN 433 are required.
- 4) The shape of the hollow sections is dependent on the size.
- 5) Countersink depth for screws to DIN 6 912.
- 6) If washers to DIN 433 are used, screws to DIN 6 912 are recommended.

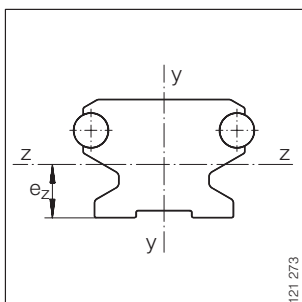

Neutral axes



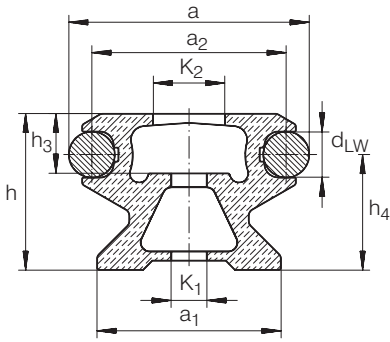

LFS..C

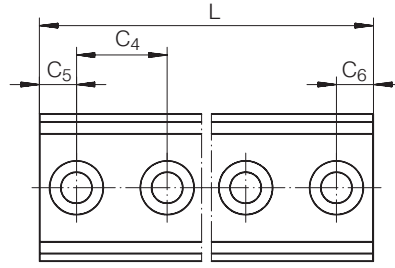

LFS, LFS..C, LFS..F
(view rotated through 90°)

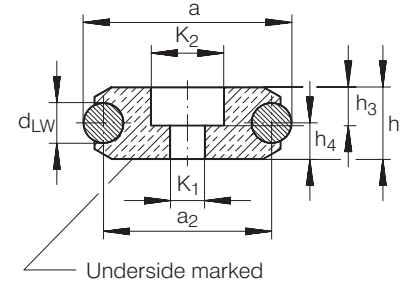

LFS..F

				MODULUS OF ELASTICITY N/mm ²	SURFACE DATA					
h ₄	h ₃	K ₁ ³⁾	K ₂		CROSS-SECTIONAL AREA mm ²	NEUTRAL AXIS				
						y-y		z-z		
						I _y mm ⁴	W _y mm ³	e _z mm	I _z mm ⁴	W _z mm ³
9	4.6	4.5	8	72,000	165	3,065	362	6.4	2,053	324
10.6	6.5	5.5	10	72,000	237	6,390	608	7.5	4,510	600
15	8	6.6	12	72,000	440	20,100	1,440	10.4	14,100	1,360
15	8	6.6	12	72,000	440	20,100	1,440	10.4	14,100	1,360
15	8	6.5	12	72,000	261	18,305	1,165	10.1	10,072	995
15	8	6.5	12	72,000	261	18,305	1,165	10.1	10,072	995
5	6.5 ⁵⁾	6.5	12	72,000	230	11,300	810	5	2,190	438
12.6	8 ⁶⁾	9	15	72,000	358	33,929	1,858	10.1	14,052	1,391
12.6	8 ⁶⁾	9	15	72,000	358	33,929	1,858	10.1	14,052	1,391
7.5	7 ⁵⁾	9	15	72,000	370	29,280	1,864	7.5	16,200	2,160
25.1	13	11	19	72,000	1,170	138,624	5,878	17.8	113,037	6,350
25.1	13	11	19	72,000	1,170	138,624	5,878	17.8	113,037	6,350
25.1	15	11	19	72,000	1,170	138,624	5,878	17.8	113,037	6,350
25.1	13	11	19	72,000	649	113,821	4,896	17.1	74,878	4,378
25.1	13	11	19	72,000	649	113,821	4,896	17.1	74,878	4,378
25.1	13	11	19	72,000	649	113,821	4,896	17.1	74,878	4,378
9	10 ⁵⁾	11	19	72,000	670	84,000	3,610	9	19,900	2,211
9	10 ⁵⁾	11	19	72,000	670	84,000	3,610	9	19,900	2,211
25.1	13 ⁶⁾	13	21	72,000	1,185	613,720	16,587	17.5	155,160	8,866
25.1	13 ⁶⁾	13	21	72,000	1,185	613,720	16,587	17.5	155,160	8,866

Guideways

LFS..N, LFS..NZZ, LFS..M, LFS..ZZ SERIES

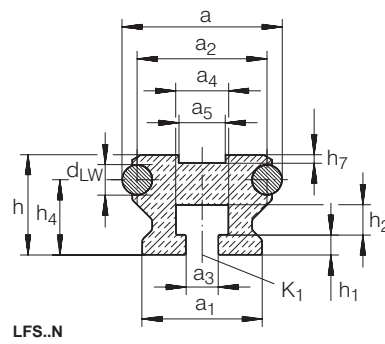

LFS..N

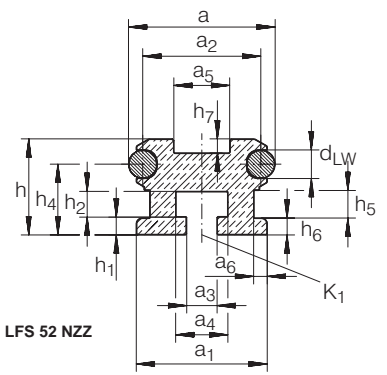

LFS 52 NZZ

For details on part numbers, descriptive suffixes and various technical references, please refer to front of this section.

For engineering or technical information contact your local sales representative or call Distributor Sales (800)523-6572 or Linear Sales (800)462-3399.

DIMENSION TABLE - Dimensions in mm																
PART NUMBER	MASS ≈ g/m	DIMENSIONS			MOUNTING DIMENSIONS											
		a	h	L ¹⁾	a ₁	a ₂	a ₃ ²⁾	a ₄	a ₅	a ₆	a ₇	C ₄ ³⁾	d _{LW}	h ₁	h ₂	h ₃
LFS 25 N	1,000	25	15	2,000	21	19	5.5	8.2	—	—	—	62.5	6	3	5	—
LFS 25 M	3,500	25	46	2,000	56	19	—	26.5	5.2	30	—	—	6	—	22	—
LFS 32 N	1,400	32	20	6,000	24	26	6.5	10.5	10.5	—	—	125	6	4	6	—
LFS 32 M	6,400	32	66.5	6,000	75	26	—	—	10.2	43	—	—	6	—	25	—
LFS 52 NZZ	3,900	52	34	8,000	46.5	42	11	18.5	18.5	4.7	—	250	10	6.4	9	—
LFS 52 M	11,200	52	98.6	8,000	112	42	18	44	10.2	80	52	—	10	—	25	—
LFS 120 ZZ	7,900	120	25	6,000	100	110	—	—	18	68	28	250 ⁵⁾	10	—	—	13

Guideway in corrosion-resistant execution: LFS..VA.

Guideway LFS 120 NZZ available without holes: LFS 120 NZZ OL.

- 1) Maximum length of single-piece guideways, longer guideways are supplied as multi-piece guideways and are marked accordingly.
- 2) For screws to DIN 931/933-8.8, special washers are included in the delivery for guideways LFS..N and LFS 52 NZZ.
- 3) Recommended distance between screws.
- 4) Core hole M8 centrally, distance from bottom edge of guideway: 57.5 mm.
- 5) C_{5 min}, C_{6 min} = 17 mm, C_{5 max}, C_{6 max} = 235 mm.

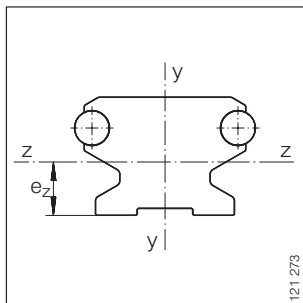

Neutral axes

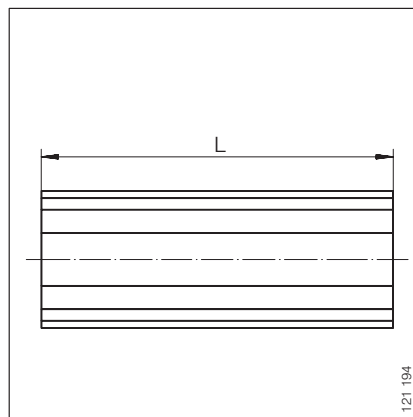

LFS..N, LFS 52 NZZ
(view rotated through 90°)

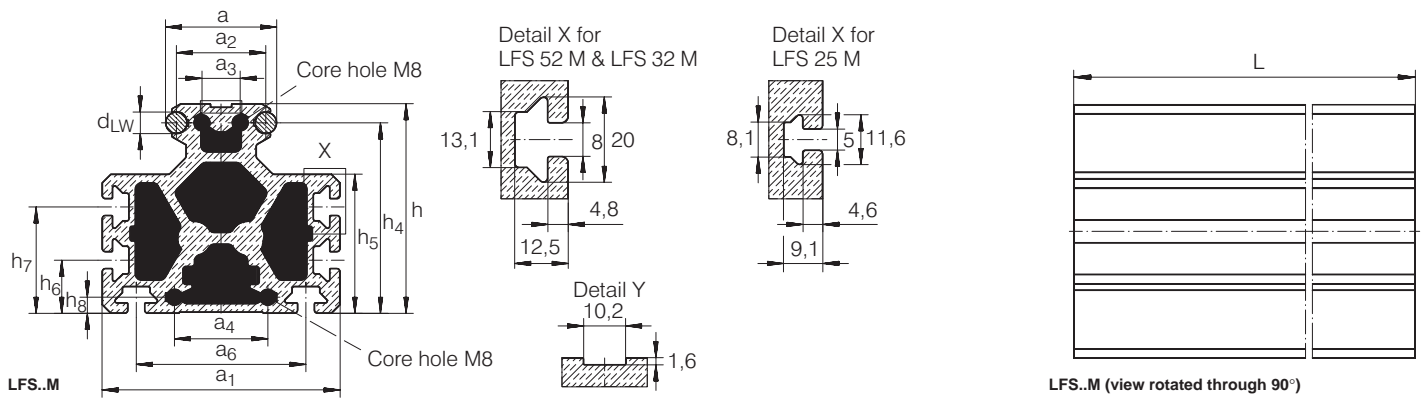

							MODULUS OF ELASTICITY	SURFACE DATA						
h ₄	h ₅	h ₆	h ₇	h ₈	K ₁	K ₂		N/mm ²	CROSS- SECTIONAL AREA	NEUTRAL AXIS				
										y-y		z-z		
										I _y	W _y	e _z	I _z	W _z
mm ⁴	mm ³	mm	mm ⁴	mm ³										
10.6	-	-	-	-	M5	-	72,000	192	5,980	570	8	4,420	530	
41.6	31.5	-	1.6	-	-	-	72,000	1,156	314,429	11,230	19.4	186,693	9,623	
15	-	-	1.6	-	M6	-	72,000	360	19,600	1,400	11.1	12,600	1,135	
61	47	-	1.6	-	-	-	72,000	2,206	1,000,234	26,672	36.8	762,105	20,707	
25.1	10	6	5	-	M10	-	72,000	994	170,350	7,327	16.8	82,786	4,927	
89.7	65.4	-	1.8	7.5	-	-	72,000	3,691	3,717,250	66,380	42.6	3,014,470	55,462	
16.1	-	-	2.5	7.5	∅ 11	∅ 19	72,000	2,468	2,330,980	40,751	12.5	117,074	9,365	

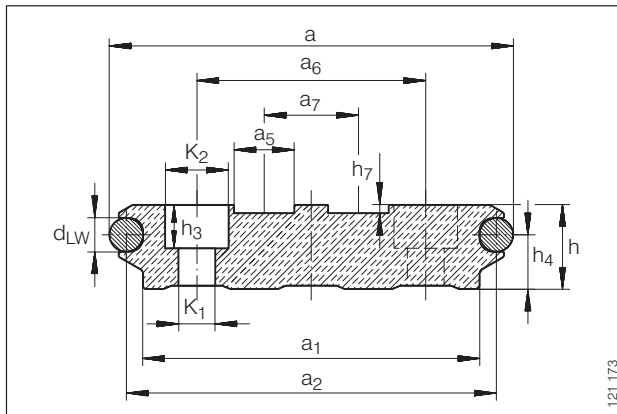

LFS 120 ZZ

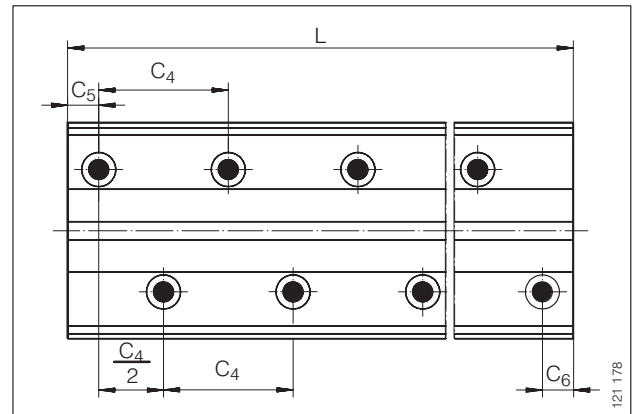

LFS 120 ZZ⁵⁾
(view rotated through 90°)



Guideways

LFS..CH, LFS..FH SERIES

For details on part numbers, descriptive suffixes and various technical references, please refer to front of this section.

For engineering or technical information contact your local sales representative or call Distributor Sales (800)523-6572 or Linear Sales (800)462-3399.

DIMENSION TABLE - Dimensions in mm												
PART NUMBER	MASS ≈ g/m	DIMENSIONS			MOUNTING DIMENSIONS							
		a	h	L ¹⁾	a ₁	a ₂	a ₆	C ₄	C ₅ ²⁾		C ₆ ²⁾	
									min.	max.	min.	max.
LFS 32 CH	900	26	20	4,000	24	23	13	125	11	116	11	116
LFS 32 CHE	900	26	20	4,000	24	23	13	62.5	11	52	11	52
LFS 32 FH	800	26	10	4,000	–	23	13	125	11	116	11	116
LFS 32 FHE	800	26	10	4,000	–	23	13	62.5	11	52	11	52
LFS 52 CH	2,100	42	34	8,000	36	37	21	250	17	235	17	235
LFS 52 CHE	2,100	42	34	8,000	36	37	21	125	17	110	17	110
LFS 52 CHEE	2,100	42	34	8,000	36	37	21	62.5	17	49	17	49
LFS 52 FH	2,300	42	18	8,000	–	37	21	250	17	235	17	235
LFS 52 FHE	2,300	42	18	8,000	–	37	21	125	17	110	17	110
LFS 52 FHEE	2,300	42	18	8,000	–	37	21	62.5	17	49	17	49

Guideway in corrosion-resistant execution: LFS..VA.

Guideways LFS..CH and LFS..FH available without holes: LFS..CH OL, LFS..FH OL.

- 1) Maximum length of single-piece guideways, longer guideways are supplied as multi-piece guideways and are marked accordingly.
- 2) Dimensions C₅ and C₆ are dependent on the guideway length L.
- 3) For screws to DIN 912-8.8, washers to DIN 433 are required for maximum loading.
- 4) Countersink depth for screws to DIN 6 912.

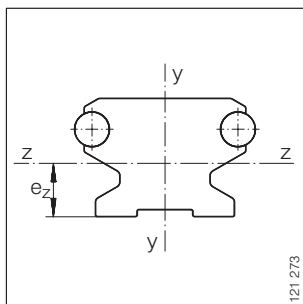

Neutral axes

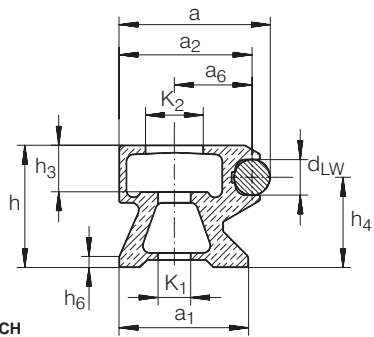

LFS..CH

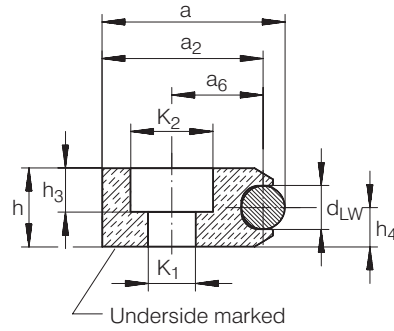

LFS..FH

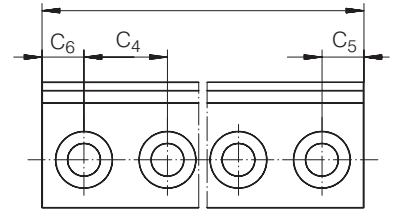

LFS..CH, LFS..FH
view rotated through 90°)

						SURFACE DATA						
d _{LW}	h ₃	h ₄	h ₆	K ₁ ³⁾	K ₂	MODULUS OF ELASTICITY N/mm ²	CROSS- SECTIONAL AREA mm ²	NEUTRAL AXIS				
								y-y		z-z		
								I _y mm ⁴	W _y mm ³	e _z mm	I _z mm ⁴	W _z mm ³
6	8	15	2	6.5	12	72,000	220	12,374	1,267	11.4	9,118	799
6	8	15	2	6.5	12	72,000	220	12,374	1,267	11.4	9,118	799
6	6.5	5	—	6.5	12	72,000	216	8,681	790	5	1,897	379
6	6.5	5	—	6.5	12	72,000	216	8,681	790	5	1,897	379
10	13	25.1	3	11	19	72,000	555	75,367	4,558	16	62,469	3,904
10	13	25.1	8	11	19	72,000	555	75,367	4,558	16	62,469	3,904
10	13	25.1	8	11	19	72,000	555	75,367	4,558	16	62,469	3,904
10	10 ⁴⁾	9	—	11	19	72,000	629	66,642	3,765	9	17,798	1,977
10	10 ⁴⁾	9	—	11	19	72,000	629	66,642	3,765	9	17,798	1,977
10	10 ⁴⁾	9	—	11	19	72,000	629	66,642	3,765	9	17,798	1,977

Curved Guideways

LFS..R SERIES

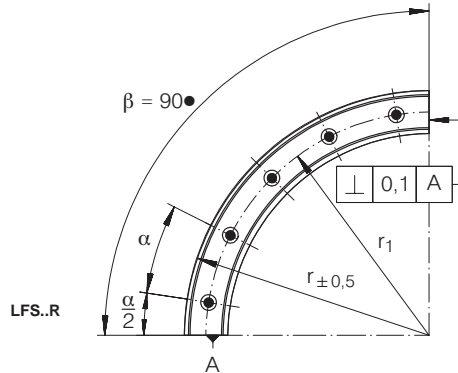
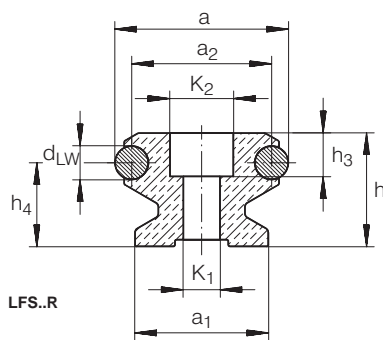

For details on part numbers, descriptive suffixes and various technical references, please refer to front of this section.

For engineering or technical information contact your local sales representative or call Distributor Sales (800)523-6572 or Linear Sales (800)462-3399.

DIMENSION TABLE - Dimensions in mm																
PART NUMBER	MASS	DIMENSIONS														
		a	h	β	a ₁	a ₂	d _{LW}	h ₃	h ₄	K ₁ ¹⁾	K ₂	x ²⁾	r	r ₁	α	$\alpha/2$
LFS 32 R 100/ 90	500	32	20	90●	24	26	6	6.5	15	6.5	12	3	100	84	30	15
LFS 32 R 100/180	1,000	32	20	180●	24	26	6	6.5	15	6.5	12	6	100	84	30	15
LFS 32 R 100/360	2,000	32	20	360●	24	26	6	6.5	15	6.5	12	12	100	84	30	-
LFS 32 R 300/ 90	1,700	32	20	90●	24	26	6	6.5	15	6.5	12	4	300	284	22.5	11.25
LFS 32 R 300/180	3,400	32	20	180●	24	26	6	6.5	15	6.5	12	8	300	284	22.5	11.25
LFS 32 R 300/360	6,800	32	20	360●	24	26	6	6.5	15	6.5	12	12	300	284	22.5	-
LFS 32 R 500/ 90	2,900	32	20	90●	24	26	6	6.5	15	6.5	12	5	500	484	18	9
LFS 32 R 500/180	5,800	32	20	180●	24	26	6	6.5	15	6.5	12	10	500	484	18	9
LFS 32 R 500/360	11,600	32	20	360●	24	26	6	6.5	15	6.5	12	12	500	484	18	-
LFS 52 R 150/ 90	2,000	52	34	90●	40	42	10	13	25.1	11	19	3	150	124	30	15
LFS 52 R 150/180	4,000	52	34	180●	40	42	10	13	25.1	11	19	6	150	124	30	15
LFS 52 R 150/360	8,000	52	34	360●	40	42	10	13	25.1	11	19	12	150	124	30	-
LFS 52 R 300/ 90	4,500	52	34	90●	40	42	10	13	25.1	11	19	4	300	274	22.5	11.25
LFS 52 R 300/180	9,000	52	34	180●	40	42	10	13	25.1	11	19	8	300	274	22.5	11.25
LFS 52 R 300/360	9,000	52	34	360●	40	42	10	13	25.1	11	19	12	300	274	22.5	-
LFS 52 R 500/ 90	7,800	52	34	90●	40	42	10	13	25.1	11	19	5	500	474	18	9
LFS 52 R 500/180	15,600	52	34	180●	40	42	10	13	25.1	11	19	10	500	474	18	9
LFS 52 R 500/360	15,600	52	34	360●	40	42	10	13	25.1	11	19	12	500	474	18	-

Guideway LFS..R in corrosion-resistant execution: LFS..R VA.

Guideway LFS..R without holes: LFS..R OL.

1) For screws to DIN 912-8.8.

2) Number of holes on curved section r₁.

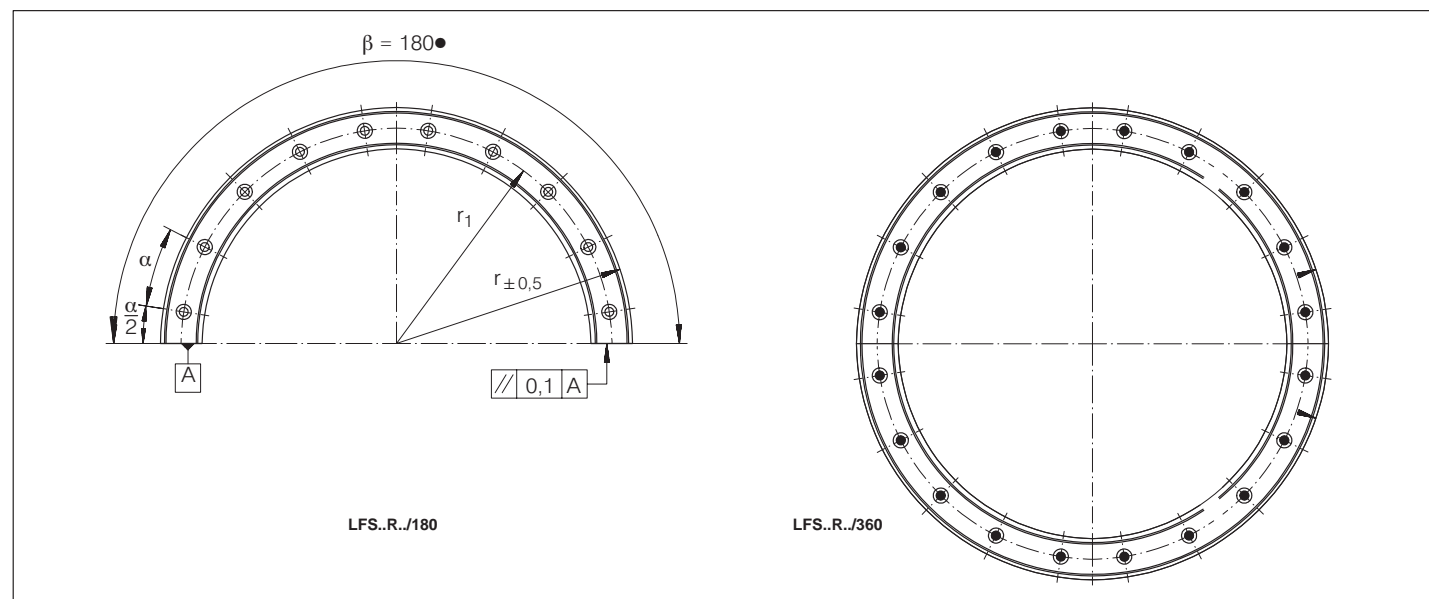

LFS..R



Shaft And Support Rail Units

TSNW SERIES

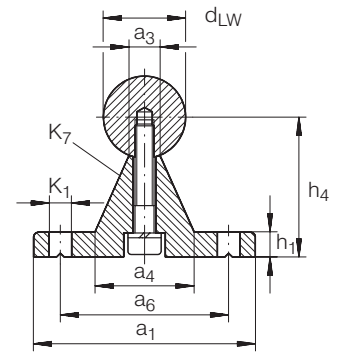
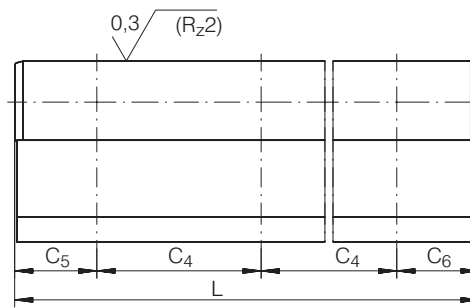

For details on part numbers, descriptive suffixes and various technical references, please refer to front of this section.

For engineering or technical information contact your local sales representative or call Distributor Sales (800)523-6572 or Linear Sales (800)462-3399.

DIMENSION TABLE - Dimensions in mm														
SHAFT DIAMETER d_{LW} h6	PART NUMBER	MASS kg/m	DIMENSIONS			MOUNTING DIMENSIONS								
			a_1	$h_4^{1)}$ ± 0.02	$L^2)$ ± 3	a_3	a_4	a_6	C_4	$C_5/C_6^{3)}$ min.	$C_5/C_6^{3)}$ max.	h_1	$K_1^{4)}$	K_7 DIN 6 912
12	TSNW 12	1.67	40	22	6,000	5.4	15	29	75	20	69	5	4.5	M4 × 20
16	TSNW 16	2.95	45	26	6,000	7	19	33	100	20	93	5	5.5	M5 × 20
20	TSNW 20	3.95	52	32	6,000	8.1	23	37	100	20	92	6	6.6	M6 × 25
25	TSNW 25	5.6	57	36	6,000	10.3	26	42	120	20	110	6	6.6	M8 × 30
30	TSNW 30	7.88	69	42	6,000	11	29	51	150	20	139	7	9	M10 × 35
40	TSNW 40	12.83	73	50	6,000	15	36	55	200	20	189	8	9	M10 × 40
50	TSNW 50	19.38	84	60	6,000	19	40	63	200	20	188	9	11	M12 × 45

1) With reference to the nominal shaft diameter, measured while clamped.

2) Maximum length of single-piece units, longer units are supplied as several pieces. Depending on the length of the shaft and support rail unit, the support rail is composed of several pieces.

3) Dimensions C_5 and C_6 are dependent on the length of the shaft and support rail unit.

4) For fixing screws to DIN 6 912 and spring washers to DIN 7 980.

Shaft And Support Rail Units

TSNW..G4 $d \leq 25\text{mm}$,
 TSNW..G5 $d > 25\text{mm}$ SERIES

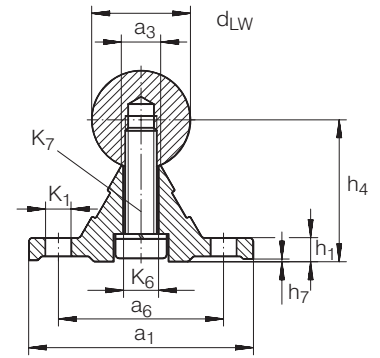
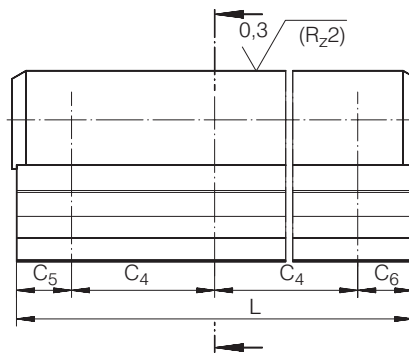

For details on part numbers, descriptive suffixes and various technical references, please refer to front of this section.

For engineering or technical information contact your local sales representative or call Distributor Sales (800)523-6572 or Linear Sales (800)462-3399.

DIMENSION TABLE - Dimensions in mm

SHAFT DIAMETER d_{LW}	PART NUMBER	MASS kg/m	DIMENSIONS			MOUNTING DIMENSIONS											ACCURACY CLASS ⁵⁾
			a_1	h_4 ¹⁾	L ²⁾	a_3	a_6	C_4	C_5/C_6 ³⁾	C_5/C_6 ³⁾	h_1	h_7	K_1 ⁴⁾	K_6	K_7		
h_6					± 2				min.	max.					DIN 6 912		
12	TSNW 12 G4	1.6	40	22 ± 0.1	4,000	5	29	75	20	69	5	0.2	4.5	4.5	M4 × 18	G4 0.03	
16	TSNW 16 G4	2.5	45	26 ± 0.1	4,000	6.8	33	100	20	93	5	0.2	5.5	5.5	M5 × 20	G4 0.03	
20	TSNW 20 G4	3.8	52	32 ± 0.1	4,000	7.8	37	100	20	92	6	0.2	6.6	6.6	M6 × 25	G4 0.03	
25	TSNW 25 G4	5.3	57	36 ± 0.1	4,000	9.8	42	120	20	110	6	0.3	6.6	9	M8 × 30	G4 0.03	
30	TSNW 30 G5	7.5	69	42 ± 0.15	4,000	11	51	150	20	139	7	0.3	9	11	M10 × 35	G5 0.04	
40	TSNW 40 G5	12.4	73	50 ± 0.15	4,000	14.5	55	200	20	189	8	0.3	9	11	M10 × 40	G5 0.04	
50	TSNW 50 G5	18.9	84	60 ± 0.15	4,000	18.5	63	200	20	188	9	0.3	11	13.5	M12 × 45	G5 0.05	

- 1) With reference to the nominal shaft diameter, measured while clamped.
- 2) Maximum length of single-piece units, the shaft protrudes beyond the support rail by about 2.5 mm at each end; longer units are supplied as several pieces.
- 3) Dimensions C_5 and C_6 are dependent on the length of the shaft and support rail unit.
- 4) For fixing screws to DIN 6 912 and spring washers to DIN 7 980.
- 5) Value for the maximum variation of dimension h_4 , measured on the same rail over a distance of 1 000 mm.

Shaft And Support Rail Units TSUW SERIES

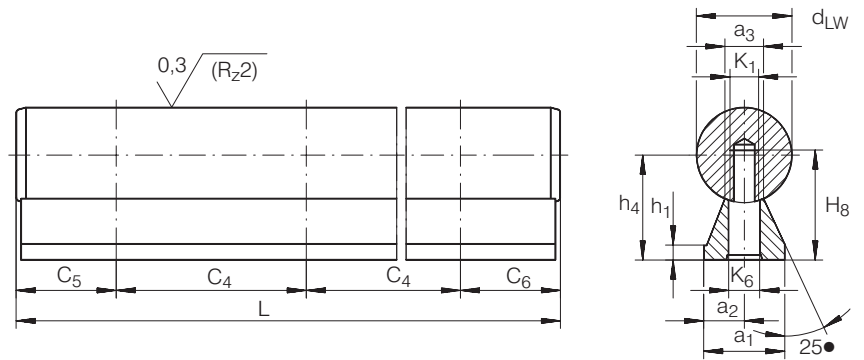

For details on part numbers, descriptive suffixes and various technical references, please refer to front of this section.

For engineering or technical information contact your local sales representative or call Distributor Sales (800)523-6572 or Linear Sales (800)462-3399.

DIMENSION TABLE - Dimensions in mm														
SHAFT DIAMETER d_{LW}	PART NUMBER	MASS kg/m	DIMENSIONS			MOUNTING DIMENSIONS								
			a_1	$h_4^{1)}$ ± 0.02	$L^{2)}$ ± 3	$a_2^{3)}$	a_3	C_4	$C_5/C_6^{4)}$ min.	$C_5/C_6^{4)}$ max.	h_1	K_1	K_6	H_8
12	TSUW 12	1.1	11	14.5	6,000	5.5	5.4	75	20	70	3	M4	4.5	16
16	TSUW 16	1.88	14	18	6,000	7	7	75	20	70	3	M5	5.5	19
20	TSUW 20	2.92	17	22	6,000	8.5	8.1	75	20	69	3	M6	6.6	23
25	TSUW 25	4.42	21	26	6,000	10.5	10.3	75	20	68	3	M8	9	28.5
30	TSUW 30	6.22	23	30	6,000	11.5	11	100	20	92	3	M10	11	32
40	TSUW 40	11.03	30	39	6,000	15	15	100	20	91	4	M12	13.5	39.5
50	TSUW 50	16.98	35	46	6,000	17.5	19	100	20	90	5	M14	15.5	46

- 1) With reference to the nominal shaft diameter, measured while clamped.
- 2) Maximum length of single-piece units (TSUW 12: $L = 1600 \pm 1.2$ mm), longer units are supplied as several pieces.
Depending on the length of the shaft and support rail unit, the support rail is composed of several pieces.
- 3) Available on request with $a_2 \pm 0.02$.
- 4) Dimensions C_5 and C_6 are dependent on the length of the shaft and support rail unit.

Shaft and Support Rail Units

TSSW SERIES

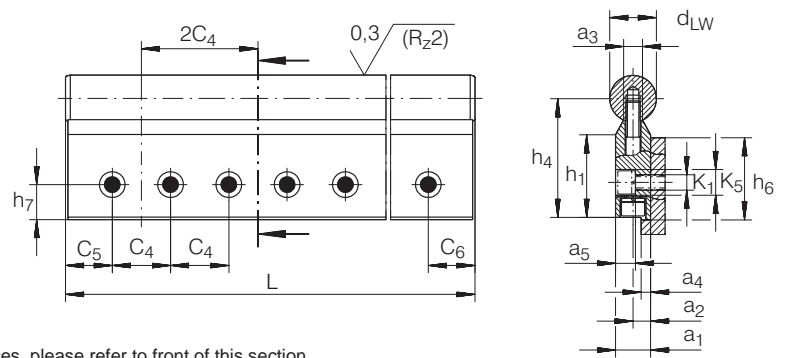

For details on part numbers, descriptive suffixes and various technical references, please refer to front of this section.

For engineering or technical information contact your local sales representative or call Distributor Sales (800)523-6572 or Linear Sales (800)462-3399.

DIMENSION TABLE - Dimensions in mm

SHAFT DIAMETER d_{LW}	PART NUMBER	MASS kg/m	DIMENSIONS			MOUNTING DIMENSIONS											
			a_1	$h_4^{1)}$	$L^{2)}$	$a_2^{1)}$	a_3	a_4	$a_5^{3)}$	C_4	$C_5/C_6^{4)}$	$C_5/C_6^{4)}$	h_1	h_6	h_7	$K_1^{3)}$	$K_5^{3)}$
				± 0.01	± 3	± 0.012					min.	max.			± 0.15		
20	TSSW 20	4.12	15	52	6,000	7.5	8.1	4	8.5	50	20	42	36.5	30	15	6.6	11
25	TSSW 25	5.98	20	62	6,000	10	10.3	5.5	11	60	20	50	38.5	36	18	9	15
30	TSSW 30	8.68	25	72	6,000	12.5	11	7	13.5	75	20	64	43	42	21	11	18
40	TSSW 40	14.3	30	88	6,000	15	15	8.5	16	100	20	88	53	50	25	13.5	20
50	TSSW 50	21.47	35	105	6,000	17.5	19	9	18.5	100	20	86	64.5	60	30	15.5	24

1) With reference to the nominal shaft diameter, measured while clamped.

2) Maximum length of single-piece units, longer units are supplied as several pieces.
Depending on the length of the shaft and support rail unit, the support rail is composed of several pieces.

3) For fixing screws to DIN 912-8.8 and spring washers to DIN 7 980.

4) Dimensions C_5 and C_6 are dependent on the length of the shaft and support rail unit

Shaft And Support Rail Units TSMW SERIES

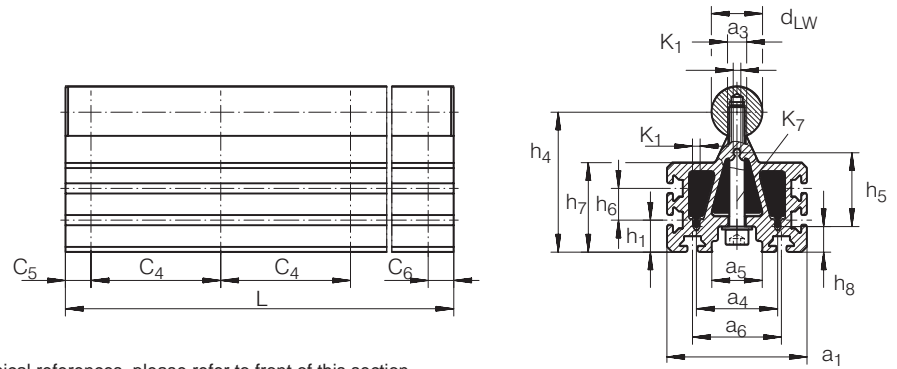

For details on part numbers, descriptive suffixes and various technical references, please refer to front of this section.

For engineering or technical information contact your local sales representative or call Distributor Sales (800)523-6572 or Linear Sales (800)462-3399.

DIMENSION TABLE - Dimensions in mm																			
SHAFT DIAMETER d_{LW}	PART NUMBER	MASS kg/m	DIMENSIONS																
			a_1	$h_4^{1)}$	$L^{2)}$ ± 3	a_3	a_4	a_5	a_6	C_4	$C_5/C_6^{4)}$ min.	$C_5/C_6^{4)}$ max.	h_1	h_5	h_6	h_7	h_8	K_1	K_7
20	TSMW 20	6.3	65	65	6,000	7.8	30	14	40	75	20	42	25	29	—	44	18	4.65	M6
25	TSMW 25	8.9	75	75	6,000	10	40	18	45	75	20	50	25	34	—	47	18	4.65	M8
30	TSMW 30	12.3	90	90	6,000	11	50	32	60	100	20	64	25	43	—	57	20	5.5	M10
40	TSMW 40 ³⁾	20.3	110	110	6,000	14.5	64	40	70	100	20	88	25	58	25	70	20	5.5	M12

- 1) With reference to the nominal shaft diameter, measured while clamped.
- 2) Maximum length of single-piece units, longer units are supplied as several pieces.
Shaft and support rail units up to the maximum length are supplied with a single-piece support rail.
- 3) Available on request.
- 4) Dimensions C_5 and C_6 are dependent on the length of the shaft and support rail unit

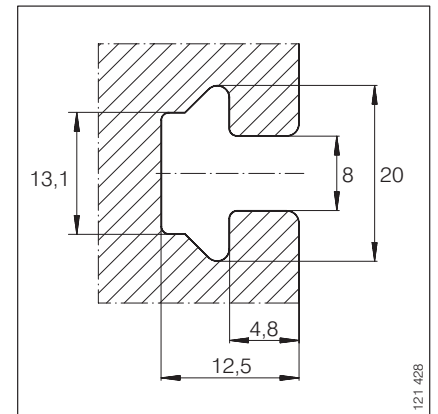

T-grooves



Lubrication And Wiper Units

AB W SERIES

Cap Wipers

AB LFR, AB LFL SERIES

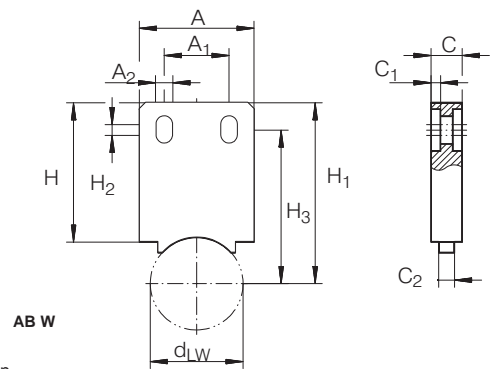

For details on part numbers, descriptive suffixes and various technical references, please refer to front of this section.

For engineering or technical information contact your local sales representative or call Distributor Sales (800)523-6572 or Linear Sales (800)462-3399.

DIMENSION TABLE - Dimensions in mm													
PART NUMBER	MASS kg	DIMENSIONS											SUITABLE FOR TRACK ROLLER LFR
		d _{LW}	A	C	H	A ₁ ±0.1	A ₂	C ₁	C ₂	H ₁	H ₂	H ₃	
AB W 10	0.03	10	22.5	10	45	10	4.5	3	5	49	4	40.3	LFR 5201-10 KDD
AB W 12	0.03	12	22.5	10	45	10	4.5	3	5	51	4	42.3	LFR 5201-12 KDD
AB W 16	0.03	16	22.5	10	45	10	4.5	3	5	52	4	43.3	LFR 5204-16 KDD
AB W 20	0.03	20	22.5	10	45	10	4.5	3	5	54	4	45.3	LFR 5206-20 KDD
AB W 25	0.03	25	37	10	45	21	5.5	3	5	54	3.5	45.3	LFR 5206-25 KDD
AB W 30	0.03	30	37	10	45	21	5.5	3	5	59	3.5	50.3	LFR 5207-30 KDD
AB W 40	0.03	40	37	10	45	21	5.5	3	5	71	3.5	62.3	LFR 5208-40 KDD

DIMENSION TABLE - Dimensions in mm													
PART NUMBER	MASS g	DIMENSIONS									SUITABLE FOR		
		A ₁	A ₃	A ₄	A ₅	C ₁	C ₂ ±0.1	H ₁	K ₄	K ₅ +0.1	TRACK ROLLER	CARRIAGE	
AB LFL 20	9	21.3	16.5	10.8	1	50	42.5	11.5	M3	10	LFR 50/..4	LFL 20	
AB LFL 20	9	21.3	16.5	10.8	1	50	42.5	11.5	M3	10	LFR 50/5	-	
AB LFR 50/8	20	31.6	25.9	15.6	2	51	28.5	15	M3	15	LFR 50/8	LFCL 25	
AB LFR 5201	20	43.3	33.4	22.3	2	56	40	21.3	M3	20	LFR 5201	-	
AB LFR 5201-LFCL	20	43.3	33.4	22.3	2	56	40	19.8	M3	20	-	LFCL 42	
AB LFR 5301	30	50	38.7	26	2	76	46	25	M3	20	LFR 5301	LFCL 86	
AB LFR 5302 ¹⁾	-	-	-	-	-	-	-	-	-	-	LFR 5302	-	

¹⁾ Please consult INA engineering service.

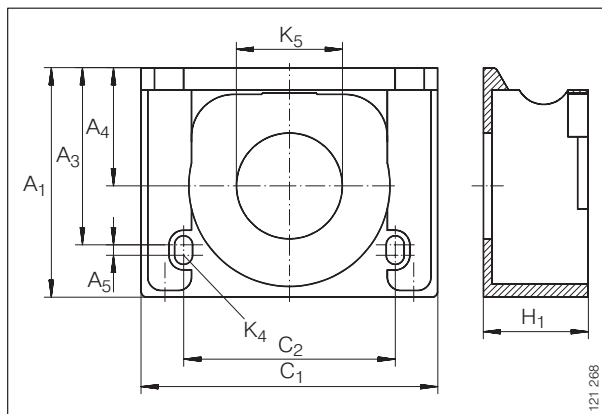

AB LFR

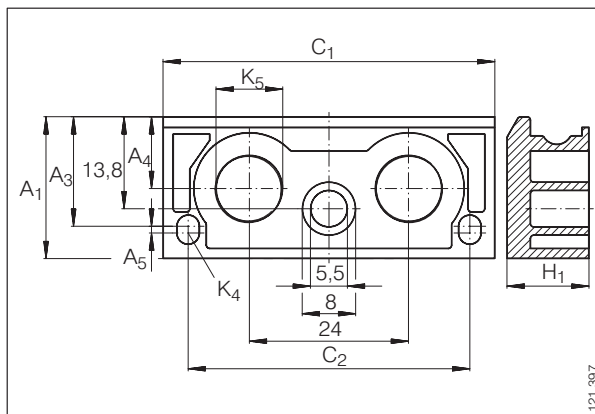

AB LFL 20

End Plates

ANS LFS SERIES

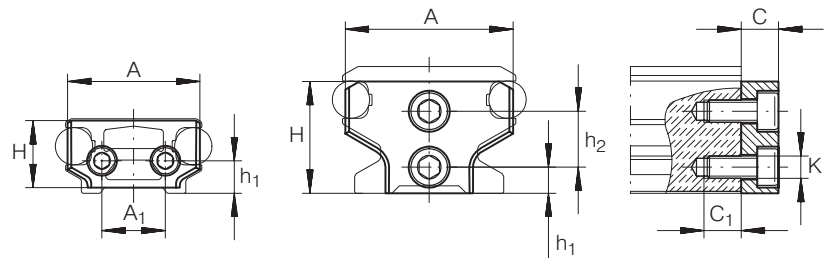

ANS LFS 42 C
ANS LFS 120

ANS LFS 25
ANS LFS 32
ANS LFS 52

For details on part numbers, descriptive suffixes and various technical references, please refer to front of this section.

For engineering or technical information contact your local sales representative or call Distributor Sales (800)523-6572 or Linear Sales (800)462-3399.

DIMENSION TABLE - Dimensions in mm										
PART NUMBER	DIMENSIONS									SUITABLE FOR GUIDEWAY
	A	A ₁	A ₂	C	C ₁	H	h ₁	h ₂	K	
ANS LFS 20	14.5	-	-	6	12	11	6.2	-	M5	LFS 20
ANS LFS 25	20	-	-	5	7	14	4	7	M3	LFS 25
ANS LFS 32	30	-	-	6	7	20	5	10	M4	LFS 32
ANS LFS 32 F	26	11	-	6	7	9	5	-	M4	LFS 32 F
ANS LFS 32 FH	22	9	9	6	7	9	5	-	M3	LFS 32 FH
ANS LFS 32 N	26	11	-	6	7	9	15	-	M4	LFS 32 N
ANS LFS 42 C	35.5	17	-	8	7	18	8	-	M4	LFS 42 C
ANS LFS 52	45	-	-	10	10	30	7	15	M6	LFS 52
ANS LFS 52 F	42	21	-	8	10	16	9	-	M5	LFS 52 F
ANS LFS 52 FH	37	6.5	21	8	10	16	9	-	M5	LFS 52 FH
ANS LFS 52 NZZ	42	21	-	8	10	16	24	-	M4	LFS 52 NZZ
ANS LFS 86C	80	54	-	8	10	30	17.5	-	M5	LFS 86 C
ANS LFS 120	114	80	-	5	10	16	8	-	M6	LFS 120

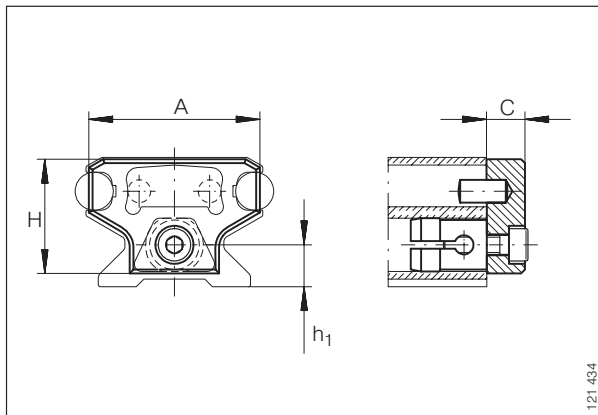

ANS LFS 52 C

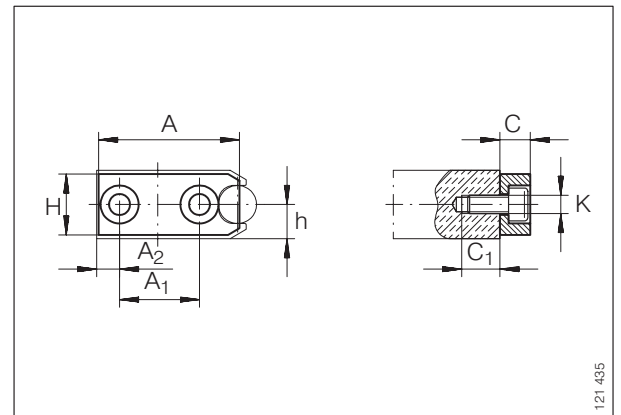

ANS LFS..FH



Lubrication And Wiper Units

AB SERIES

Side Plates

ABAL SERIES

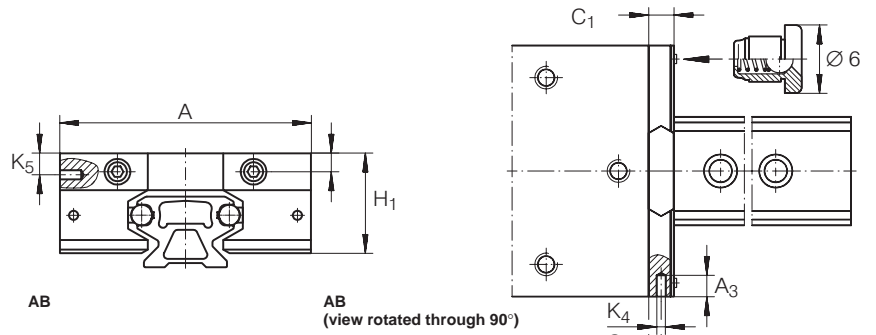

For details on part numbers, descriptive suffixes and various technical references, please refer to front of this section.

For engineering or technical information contact your local sales representative or call Distributor Sales (800)523-6572 or Linear Sales (800)462-3399.

DIMENSION TABLE - Dimensions in mm										
PART NUMBER	MASS ≈ g	DIMENSIONS								SUITABLE FOR TRACK ROLLER
		A	A ₃	C ₁	C ₇	H ₁	H ₄	H ₅	K ₄ for screws to DIN 7972	
AB 32	30	80	6	11	5	32	7	7	St 2.9	LFL 32
AB 32	30	80	6	11	5	32	7	7	St 2.9	LFDL 32
AB 52	100	120	20	18	8.5	49.5	9.5	15	St 4.8	LFL 52
AB 52	100	120	20	18	8.5	49.5	9.5	15	St 4.8	LFDL 52
AB 52/1	130	135	20	18	8.5	55	12	20.6	St 4.8	LFL 52 E

DIMENSION TABLE - Dimensions in mm							
PART NUMBER	MASS ≈ g	DIMENSIONS					SUITABLE FOR CARRIAGE
		A	A ₁	C	C ₇	H ₁	
ABAL 32	30	86	3	112	100	32	LFL 32
ABAL 52	40	130	5	136	117	49.5	LFL 52
ABAL 52/1	50	145	5	186	167	55	LFL 52 E

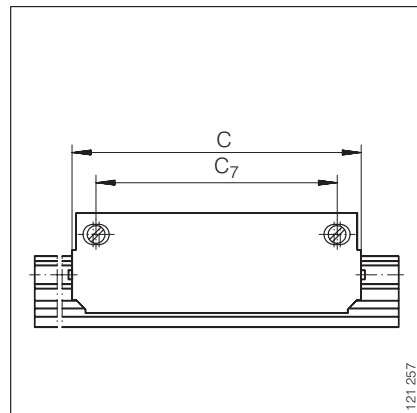

ABAL

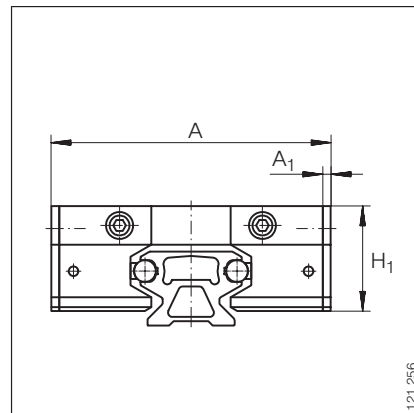

ABAL

End Stops PAH, PASTP SERIES

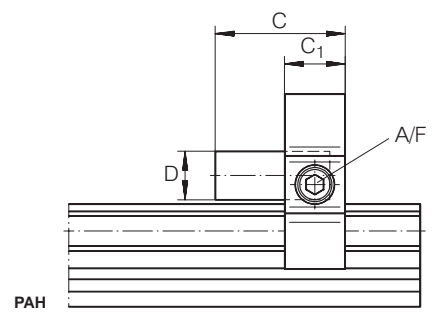
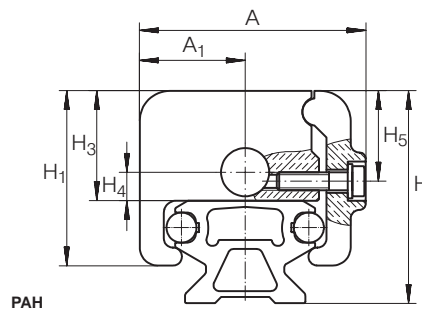

For details on part numbers, descriptive suffixes and various technical references, please refer to front of this section.

For engineering or technical information contact your local sales representative or call Distributor Sales (800)523-6572 or Linear Sales (800)462-3399.

DIMENSION TABLE - Dimensions in mm													
PART NUMBER	MASS ≈ g	DIMENSIONS											SUITABLE FOR GUIDEWAY
		A	A ₁	C	C ₁	D	H	H ₁	H ₃	H ₄	H ₅	A/F	
PAH 32	50	46	21	30	15	10	39	32	19	7	14	5	LFS 32 C, N
PAH 52	170	75	35	43	20	16	70.5	58	36.5	9.5	30	6	LFS 52 C, NZZ

DIMENSION TABLE - Dimensions in mm						
PART NUMBER	MASS ≈ g	DIMENSIONS				SUITABLE FOR GUIDEWAY
		D	H ₃	K ₅	H	
PASTP 20	8	20	7	M5	22.2	LFS 20
PASTP 25	8	20	7	M5	25	LFS 25
PASTP 32	10	16	11	M6	31	LFS 32
PASTP 42	10	16	11	M6	31	LFS 42 C
PASTP 52	10	20	11	M8	45	LFS 52
PASTP 86	10	20	11	M8	45	LFS 86 C

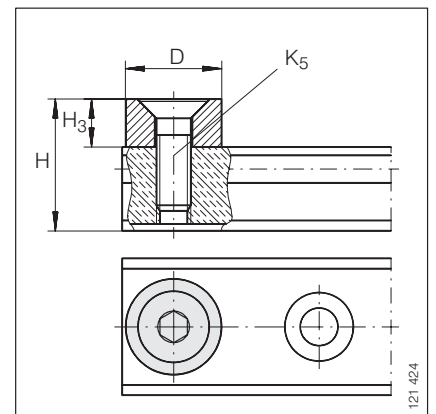

Groove Strips

NAD SERIES

End Covers

KA LFS..C, KA LFS..M SERIES

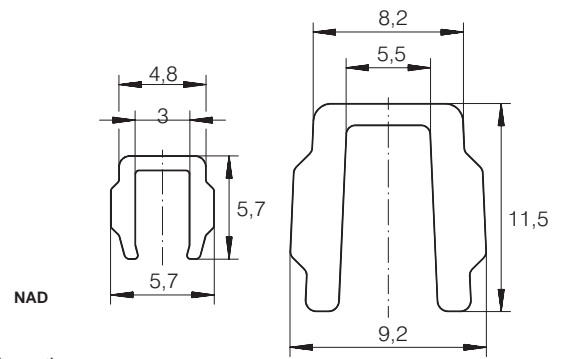

For details on part numbers, descriptive suffixes and various technical references, please refer to front of this section.

For engineering or technical information contact your local sales representative or call Distributor Sales (800)523-6572 or Linear Sales (800)462-3399.

DIMENSION TABLE - Dimensions in mm		
PART NUMBER	MASS ≈ g/m	SUITABLE FOR GUIDEWAY
NAD 5 × 5,7	12	LFS 25 M
NAD 8 × 11,5	27	LFS 32 M
NAD 8 × 11,5	27	LFS 52 M

DIMENSION TABLE - Dimensions in mm							
PART NUMBER	MASS ≈ g	DIMENSIONS					SUITABLE FOR GUIDEWAY
		a ₈	a ₉	c ₁	h ₈	h ₉	
KA LFS 25 M	10	24.4	55.4	3	45.4	30.9	LFS 25 M
KA LFS 32 C	10	31.4	23.4	3	19.4	—	LFS 32 C
KA LFS 32 M	12	31.4	74.4	3	59.9	46.4	LFS 32 M
KA LFS 42 C	12	41.4	27.4	3	19.4	—	LFS 42 C
KA LFS 52 C	13	51.6	39.4	3	33.4	—	LFS 52 C
KA LFS 52 M	15	51.6	111.4	4	98	64.8	LFS 52 M
KA LFS 86 C	15	85.6	70.4	4	33.4	—	LFS 86 C

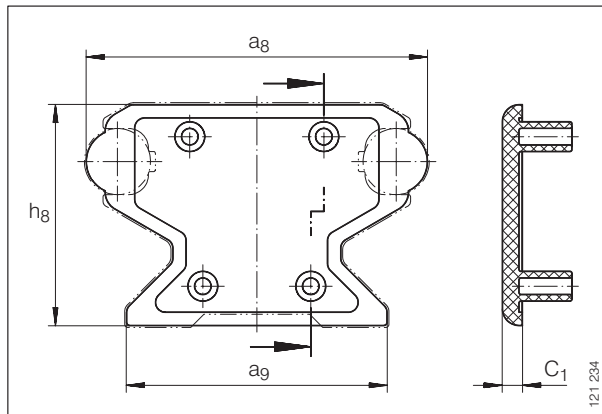

KA LFS..C

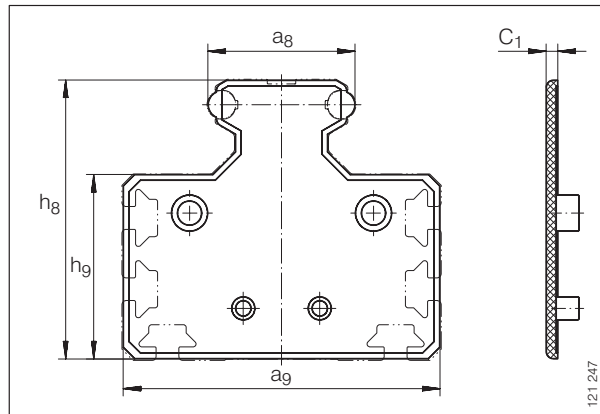

KA LFS..M

Adapter ABTKO LFKL SERIES

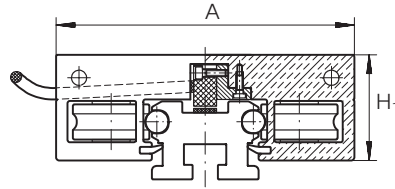

ABTKO LFKL

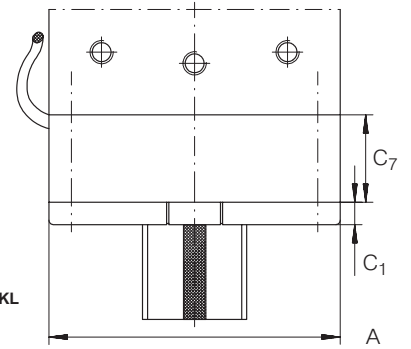

ABTKO LFKL

For details on part numbers, descriptive suffixes and various technical references, please refer to front of this section.

For engineering or technical information contact your local sales representative or call Distributor Sales (800)523-6572 or Linear Sales (800)462-3399.

DIMENSION TABLE - Dimensions in mm						
PART NUMBER	MASS ≈ g	DIMENSIONS				SUITABLE FOR CARRIAGE
		A	H ₁	C ₇	C ₁	
ABTKO LFKL 32	200	86	32	39	7	LFKL 32
ABTKO LFKL 52	400	130	46.1	39	10	LFKL 52
ABTKO LFKL 52 E	500	145	53.8	39	10	LFKL 52 E
ABTKO LFKL 52 EE	500	155	55	39	10	LFKL 52 EE

Self-Aligning Linear Ball Bearings

KX, KX..PP, KXO, KXO..PP SERIES

- MAX³ Maximum Performance
- Closed and open
- With gap seal or contact seal on both sides

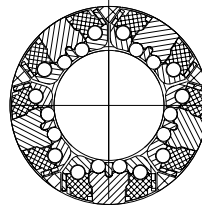

KX, KX..PP

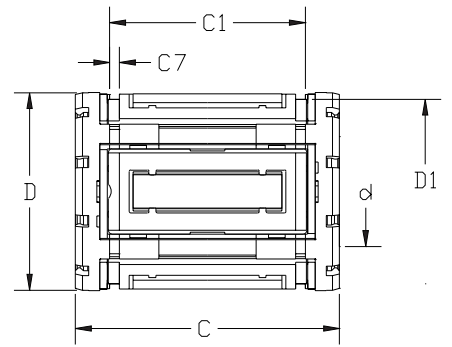

For details on part numbers, descriptive suffixes and various technical references, please refer to front of this section.
For engineering or technical information contact your local sales representative or call Distributor Sales (800)523-6572.

DIMENSION TABLE • Inch Dimensions

SHAFT DIAMETER	PART NUMBER ¹⁾	WEIGHT lbs	DIMENSIONS		
			d	D	C
1/2	KX 08	0.0430	0.500 _{-0.005}	0.875	1.250 _{-0.020}
	KXO 08	0.0317	0.500 _{-0.005}	0.875	1.250 _{-0.020}
5/8	KX 10	0.0875	0.625 _{-0.005}	1.125	1.500 _{-0.020}
	KXO 10	0.0719	0.625 _{-0.005}	1.125	1.500 _{-0.020}
3/4	KX 12	0.1155	0.750 _{-0.005}	1.250	1.625 _{-0.020}
	KXO 12	0.0948	0.750 _{-0.005}	1.250	1.625 _{-0.020}
1	KX 16	0.2425	1.000 _{-0.005}	1.563	2.250 _{-0.020}
	KXO 16	0.1962	1.000 _{-0.005}	1.563	2.250 _{-0.020}
1 1/4	KX 20	0.4861	1.250 _{-0.006}	2.000	2.625 _{-0.025}
	KXO 20	0.3933	1.250 _{-0.006}	2.000	2.625 _{-0.025}
1 1/2	KX 24	0.7749	1.500 _{-0.006}	2.375	3.000 _{-0.030}
	KXO 24	0.6283	1.500 _{-0.006}	2.375	3.000 _{-0.030}
2	KX 32	1.5139	2.000 _{-0.008}	3.000	4.000 _{-0.040}
	KXO 32	1.2269	2.000 _{-0.008}	3.000	4.000 _{-0.040}

- 1) Linear ball bearings sealed on both sides: suffix "PP".
- 2) Load ratings apply only for hardened (670 to 840 HV) and ground shaft raceways.
- 3) Load rating in main load direction.
- 4) Load ratings to ISO/C 14 728-1 (maximum values).

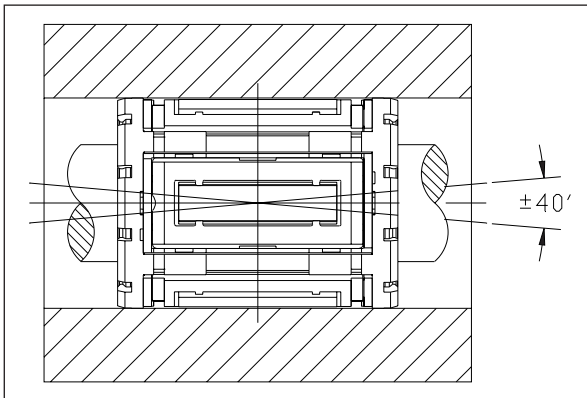

Misalignment compensation ±40'



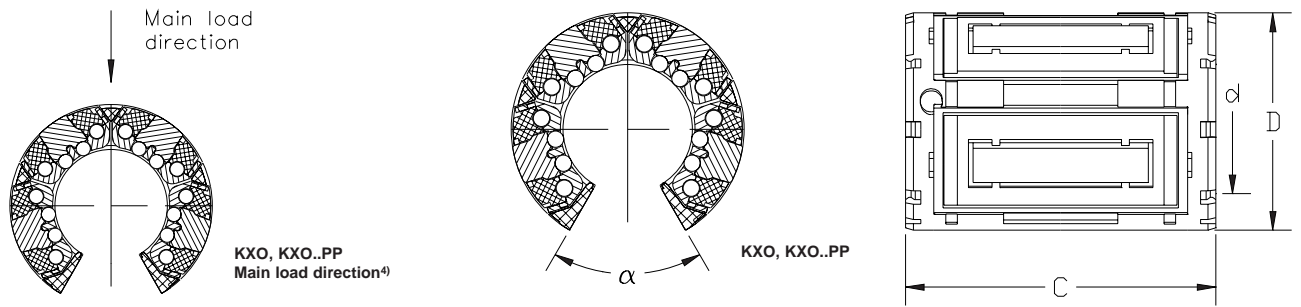

DIMENSION TABLE • Inch Dimensions											
MOUNTING DIMENSION							NUMBER OF BALL ROWS	LOAD RATINGS ²⁾⁴⁾		ACCESSORIES SUITABLE SNAP RINGS TO N1400	SHAFT DIAMETER
D ₁	C ₇	C ₁	α deg.	d ₁	t	S		DYN. C ₀ lbf	STAT. C ₀ lbf		
0.821	0.046	1.032 _{-0.020}	-	-	-	-	6	275	200	1/2 x .035	1/2
-	-	1.032 _{-0.020}	60	0.136	-	0.625	4	260 ³⁾	190 ³⁾	1/2 x .035	-
1.059	0.056	1.112 _{-0.020}	-	-	-	-	10	290	260	5/8 x .035	5/8
-	-	1.112 _{-0.020}	60	0.105	0.039	0.125	8	290 ³⁾	260 ³⁾	5/8 x .035	-
1.176	0.056	1.272 _{-0.020}	-	-	-	-	10	430	370	3/4 x .042	3/4
-	-	1.272 _{-0.020}	60	0.136	0.059	0.125	8	430 ³⁾	370 ³⁾	3/4 x .042	-
1.469	0.068	1.886 _{-0.020}	-	-	-	-	10	810	720	1 x .042	1
-	-	1.886 _{-0.020}	64	0.136	0.047	0.125	8	810 ³⁾	720 ³⁾	1 x .042	-
1.886	0.068	2.011 _{-0.025}	-	-	-	-	10	1490	1190	1 1/4 x .050	1 1/4
-	-	2.011 _{-0.025}	64	0.201	0.090	0.188	8	1490 ³⁾	1190 ³⁾	1 1/4 x .050	-
2.239	0.086	2.422 _{-0.030}	-	-	-	-	10	2090	1550	1 1/2 x .050	1 1/2
-	-	2.422 _{-0.030}	64	0.201	0.090	0.188	8	2090 ³⁾	1550 ³⁾	1 1/2 x .050	-
2.838	0.103	3.206 _{-0.040}	-	-	-	-	10	3500	2750	2 x .062	2
-	-	3.206 _{-0.040}	60	0.265	0.090	0.312	8	3500 ³⁾	2750 ³⁾	2 x .062	-

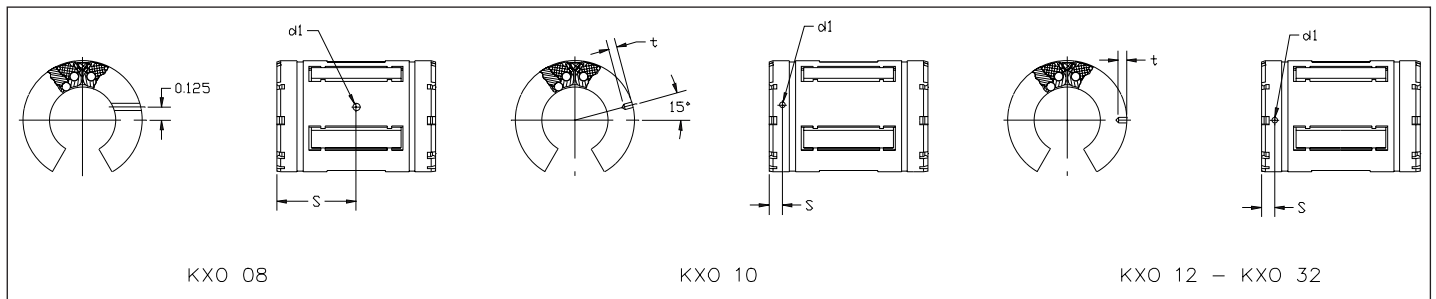

Location holes



Self-Aligning Mounted Units

KGX, KGX..PP, KGXO, KGXO..PP SERIES

- MAX³ Maximum Performance
- Closed and open
- Linear ball bearing with gap seal or contact seal on both sides

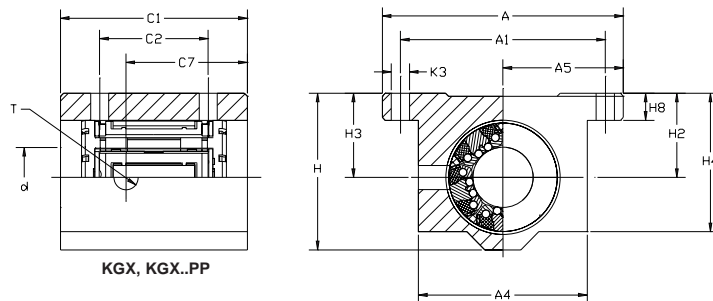

For details on part numbers, descriptive suffixes and various technical references, please refer to front of this section.
For engineering or technical information contact your local sales representative or call Distributor Sales (800)523-6572.

DIMENSION TABLE • Inch Dimensions

SHAFT DIAMETER	PART NUMBER ¹⁾	WEIGHT lbs	d	DIMENSIONS			MOUNTING DIMENSIONS			
				A	C ₁	H	A ₄	A ₅ ±0.001	A ₆	A ₇
1/2	KGX 08	0.249	0.500	2.000	1.688	1.250	1.375	1.000	-	-
	KGXO 08	0.216	0.500	2.000	1.500	1.100	-	1.000	0.688	0.905
5/8	KGX 10	0.464	0.625	2.500	1.938	1.625	1.750	1.250	-	-
	KGXO 10	0.395	0.625	2.500	1.750	1.375	-	1.250	0.875	1.095
3/4	KGX 12	0.581	0.750	2.750	2.063	1.750	1.875	1.375	-	-
	KGXO 12	0.495	0.750	2.750	1.875	1.535	-	1.375	0.937	1.161
1	KGX 16	1.213	1.000	3.250	2.813	2.188	2.375	1.625	-	-
	KGXO 16	1.053	1.000	3.250	2.625	1.975	-	1.625	1.188	1.457
1 1/4	KGX 20	2.430	1.250	4.000	3.625	2.813	3.000	2.000	-	-
	KGXO 20	2.104	1.250	4.000	3.375	2.458	-	2.000	1.500	1.831
1 1/2	KGX 24	3.573	1.500	4.750	4.000	3.250	3.500	2.375	-	-
	KGXO 24	3.154	1.500	4.750	3.750	2.910	-	2.375	1.750	2.087
2	KGX 32	7.196	2.000	6.000	5.000	4.063	4.500	3.000	-	-
	KGXO 32	6.306	2.000	6.000	4.750	3.660	-	3.000	2.250	2.638

- 1) Linear ball bearings sealed on both sides: suffix "PP".
- 2) Load ratings apply only for hardened (670 to 840 HV) and ground shaft raceways.
- 3) Load rating in main load direction.
- 4) Load ratings to ISO/C 14 728-1 (maximum values).



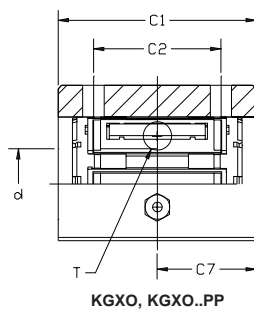

KGXO, KGXO..PP

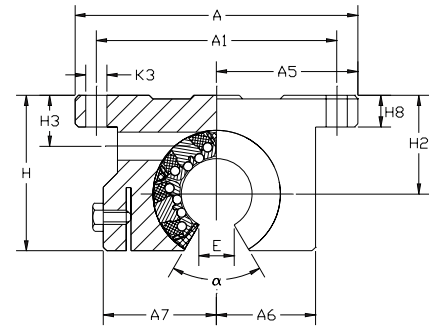

DIMENSION TABLE • Inch Dimensions													
MOUNTING DIMENSIONS											LOAD RATINGS ²⁾⁴⁾		SHAFT DIAMETER
C ₇	H ₂ ±0.001	H ₃	H ₄	H ₈	T	E	α deg.	A ₁ ±0.01	C ₂ ±0.01	K ₃	dyn. C lbf	stat. C ₀ lbf	
0.844	0.687	0.690	1.125	0.250	NIP A1	-	-	1.688	1.000	0.156	275	200	1/2
0.520	0.687	0.370	-	0.250	NIP A1	0.313	60	1.688	1.000	0.156	260 ³⁾	190 ³⁾	5/8
1.260	0.875	0.700	1.437	0.281	1/4-28	-	-	2.125	1.125	0.188	290	260	
0.875	0.875	0.450	-	0.281	1/4-28	0.375	60	2.125	1.130	0.188	290 ³⁾	260 ³⁾	3/4
1.340	0.937	0.937	1.563	0.313	1/4-28	-	-	2.375	1.250	0.188	430	370	
0.937	0.937	0.510	-	0.313	1/4-28	0.438	60	2.375	1.250	0.188	430 ³⁾	370 ³⁾	1
1.950	1.187	1.187	1.938	0.375	1/4-28	-	-	2.875	1.750	0.218	810	720	
1.312	1.187	0.730	-	0.375	1/4-28	0.563	60	2.875	1.750	0.218	810 ³⁾	720 ³⁾	1 1/4
2.430	1.500	1.500	2.500	0.437	1/4-28	-	-	3.500	2.000	0.218	1490	1190	
1.688	1.500	0.800	-	0.437	1/4-28	0.625	60	3.500	2.000	0.218	1490 ³⁾	1190 ³⁾	1 1/2
2.750	1.750	1.750	2.875	0.500	1/4-28	-	-	4.125	2.500	0.281	2090	1550	
1.875	1.750	0.840	-	0.500	1/4-28	0.750	60	4.125	2.500	0.281	2090 ³⁾	1550 ³⁾	2
3.420	2.125	2.125	3.625	0.625	1/4-28	-	-	5.250	3.250	0.406	3500	2750	
2.375	2.125	1.100	-	0.625	1/4-28	1.000	60	5.250	3.250	0.406	3500 ³⁾	2750 ³⁾	

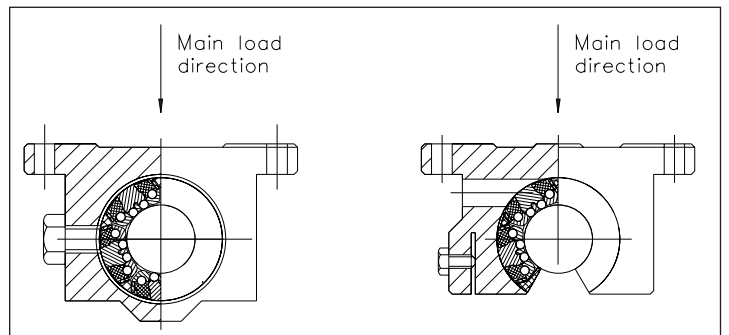

KGX, KGX..PP, KGXO, KGXO..PP
Main load direction⁴⁾



Self-Aligning Tandem Mounted Units

KTX, KTX..PP, KTXO, KTXO..PP SERIES

- MAX³ Maximum Performance
- Closed and open
- Linear ball bearing with gap seal or contact seal on both sides

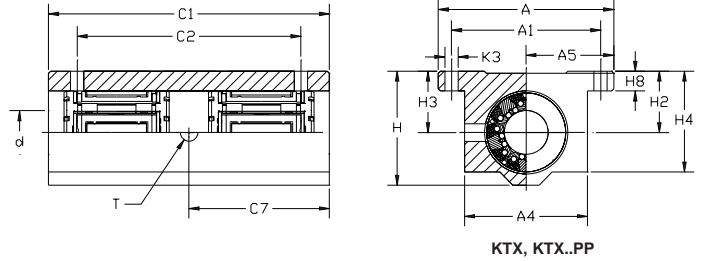

For details on part numbers, descriptive suffixes and various technical references, please refer to front of this section.
For engineering or technical information contact your local sales representative or call Distributor Sales (800)523-6572.

DIMENSION TABLE • Inch Dimensions

SHAFT DIAMETER	PART NUMBER ¹⁾	WEIGHT lbs	d	DIMENSIONS			MOUNTING DIMENSIONS			
				A	C ₁	H	A ₄	A ₅ ±0.001	A ₆	A ₇
1/2	KTX 08	0.443	0.500	2.000	3.50	1.250	1.375	1.000	-	-
	KTXO 08	0.369	0.500	2.000	3.50	1.100	-	1.000	0.688	0.905
5/8	KTX 10	1.065	0.625	2.500	4.00	1.625	1.750	1.250	-	-
	KTXO 10	0.887	0.625	2.500	4.00	1.375	-	1.250	0.875	1.095
3/4	KTX 12	1.253	0.750	2.750	4.50	1.750	1.875	1.375	-	-
	KTXO 12	1.071	0.750	2.750	4.50	1.535	-	1.375	0.937	1.161
1	KTX 16	2.597	1.000	3.250	6.00	2.188	2.375	1.625	-	-
	KTXO 16	2.228	1.000	3.250	6.00	1.975	-	1.625	1.188	1.457
1 1/4	KTX 20	5.529	1.250	4.000	7.50	2.813	3.000	2.000	-	-
	KTXO 20	4.774	1.250	4.000	7.50	2.485	-	2.000	1.500	1.831
1 1/2	KTX 24	8.316	1.500	4.750	9.00	3.250	3.500	2.375	-	-
	KTXO 24	7.378	1.500	4.750	9.00	2.910	-	2.375	1.750	2.087

- 1) Linear ball bearings sealed on both sides: suffix "PP".
- 2) Load ratings apply only for hardened (670 to 840 HV) and ground shaft raceways.
- 3) Load rating in main load direction.
- 4) Load ratings to ISO/C 14 728-1 (maximum values).



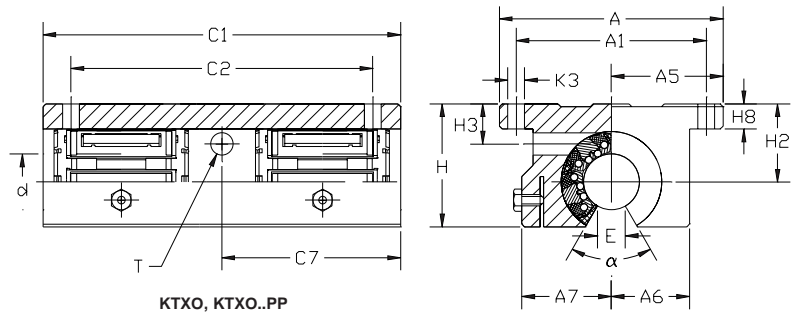

DIMENSION TABLE • Inch Dimensions													
MOUNTING DIMENSIONS											LOAD RATINGS ²⁾⁴⁾		SHAFT DIAMETER
C ₇	H ₂ ±0.001	H ₃	H ₄	H ₈	T	E	α deg.	A ₁ ±0.01	C ₂ ±0.01	K ₃	dyn. C lbf	stat. C lbf	
1.750	0.687	0.687	1.125	0.250	NIP A1	-	-	1.688	2.500	0.156	550	400	1/2
1.750	0.687	0.370	-	0.250	NIP A1	0.313	60	1.688	2.500	0.156	520 ³⁾	380 ³⁾	
2.000	0.875	0.875	1.437	0.281	1/4-28	-	-	2.125	3.000	0.188	580	520	5/8
2.000	0.875	0.450	-	0.281	1/4-28	0.375	60	2.125	3.000	0.188	580 ³⁾	520 ³⁾	
2.250	0.937	0.937	1.563	0.313	1/4-28	-	-	2.375	3.500	0.188	860	740	3/4
2.250	0.937	0.510	-	0.313	1/4-28	0.438	60	2.375	3.500	0.188	860 ³⁾	740 ³⁾	
3.000	1.187	1.187	1.938	0.375	1/4-28	-	-	2.875	4.500	0.218	1620	1440	1
3.000	1.187	0.730	-	0.375	1/4-28	0.563	60	2.875	4.500	0.218	1620 ³⁾	1440 ³⁾	
3.750	1.500	1.500	2.500	0.437	1/4-28	-	-	3.500	5.500	0.218	3000	2380	1 1/4
3.750	1.500	0.800	-	0.437	1/4-28	0.625	60	3.500	5.500	0.218	3000 ³⁾	2380 ³⁾	
4.500	1.750	1.750	2.875	0.500	1/4-28	-	-	4.125	6.500	0.281	4200	3100	1 1/2
4.500	1.750	0.800	-	0.500	1/4-28	0.750	60	4.125	6.500	0.281	4200 ³⁾	3100 ³⁾	

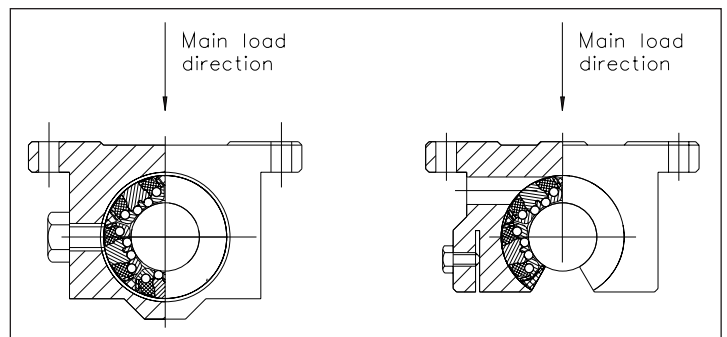

KTX, KTX..PP, KTXO, KTXO..PP
Main load direction⁴⁾

Self-Aligning Linear Ball Bearings

KS, KS..PP, KSO, KSO..PP SERIES

- MAX³ Maximum Performance
- Light range - metric sizes
- Closed and open designs
- Gap seals or contact seals on both sides

Main Load Direction

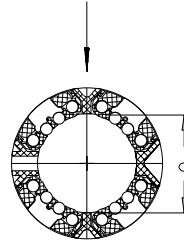

KS, KS..PP

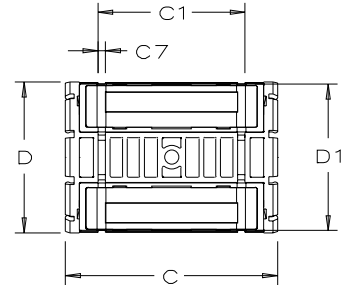

For details on part numbers, descriptive suffixes and various technical references, please refer to front of this section.
For engineering or technical information contact your local sales representative or call Distributor Sales (800)523-6572.

DIMENSION TABLE • Dimensions in mm

SHAFT DIAMETER d	PART NUMBER ¹⁾	MASS =kg	DIMENSIONS			MOUNTING DIMENSIONS	
			d	D	C	A ₆ ²⁾	C ₁ H13
12	KS 12	0.018	12	22	32	-	22.6
	KSO 12	0.013	12	22	32	7.6	-
16	KS 16	0.028	16	26	36	-	24.6
	KSO 16	0.019	16	26	36	10.1	-
20	KS 20	0.051	20	32	45	-	31.2
	KSO 20	0.038	20	32	45	10	-
25	KS 25	0.102	25	40	58	-	43.7
	KSO 25	0.075	25	40	58	12.5	-
30	KS 30	0.172	30	47	68	-	51.7
	KSO 30	0.135	30	47	68	14.3	-
40	KS 40	0.335	40	62	80	-	60.3
	KSO 40	0.259	40	62	80	18.2	-
50	KS 50	0.589	50	75	100	-	77.3
	KSO 50	0.454	50	75	100	22.7	-

- 1) Linear ball bearings sealed on both sides: suffix "PP".
- 2) Dimension A₆ on diameter d.
- 3) Hole arrangement symmetrical with bearing width C.
- 4) The basic load ratings apply only for hardened (670 to 840 HV) and ground shaft raceways. Basic load ratings in accordance with DIN 636-1.
- 5) Basic load rating in main load direction.

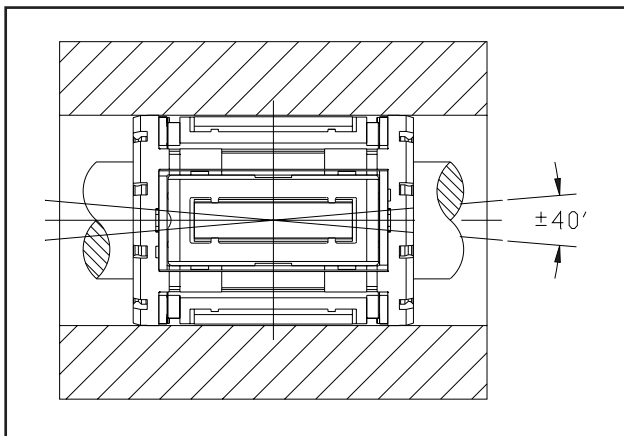

Compensation of misalignment ±40'



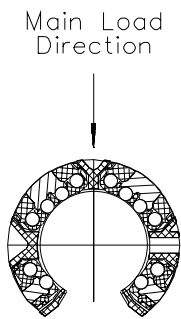

KSO, KSO..PP

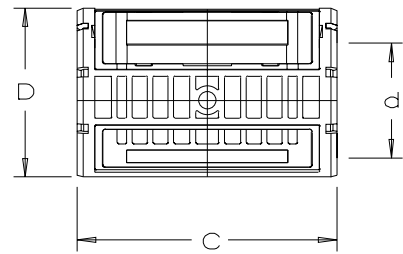
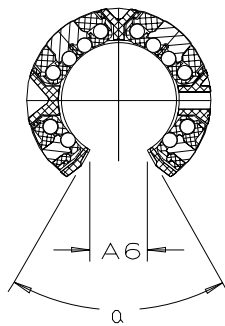

DIMENSION TABLE • Dimensions in mm										
MOUNTING DIMENSIONS						BALL ROWS	BASIC LOAD RATINGS 4)5)		ACCESSORIES	
C ₇	D ₁	H ₁₀	K ₁ ³⁾	K ₄ ³⁾	α	QUANTITY	dyn. C _{max} N	stat. C _{0max} N	SUITABLE SNAP RING TO DIN 471	SHAFT DIAMETER d
1.3	21	-	3	-	-	8	900	810	22x1.2	12
-	-	-	3	3	78	6	900	810	-	16
1.3	25	-	3	-	-	8	1,430	1,160	27x1.2	
-	-	-	3	3	78	6	1,430	1,160	-	
1.6	30.7	-	3	-	-	8	2,200	1,730	33x1.5	20
-	-	-	3	3	60	6	2,200	1,730	-	25
1.85	38	-	3.5	-	-	8	3,950	3,250	42x1.75	
-	-	1.5	3.5	3	60	6	3,950	3,250	-	
1.85	44.7	-	3.5	-	-	8	5,900	4,500	48x1.75	30
-	-	2	3.5	3	57	6	5,900	4,500	-	40
2.15	59.4	-	3.5	-	-	8	10,200	7,200	63x2	
-	-	1.5	3.5	3	54	6	10,200	7,200	-	
2.65	71.4	-	4.5	-	-	8	15,100	10,400	75x2.5	50
-	-	2.5	4.5	5	54	6	15,100	10,400	-	

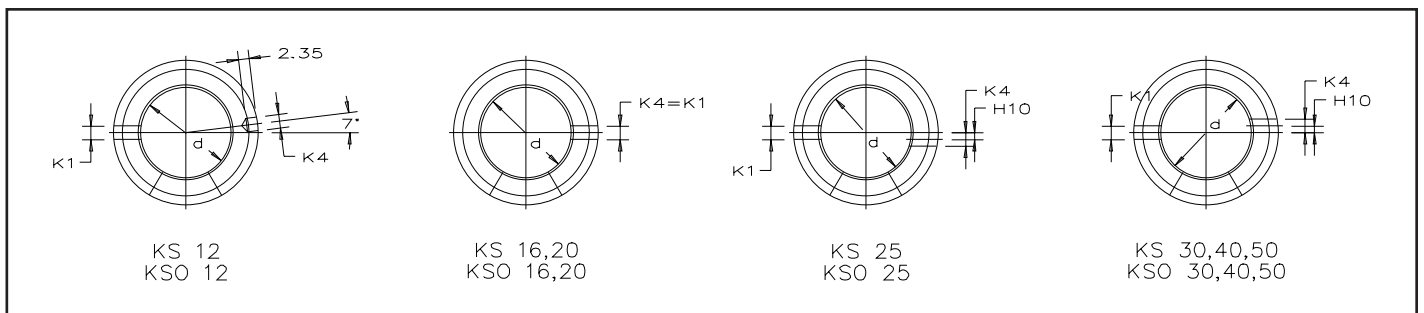

Fixing holes



Linear Ball Bearings

KGSG..PP, KGSS..PP, KGSO..PP SERIES

- MAX³ Maximum Performance
- Closed and open designs
- Contact seals on both sides

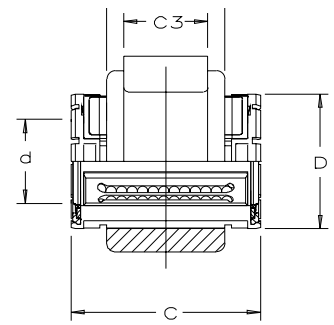
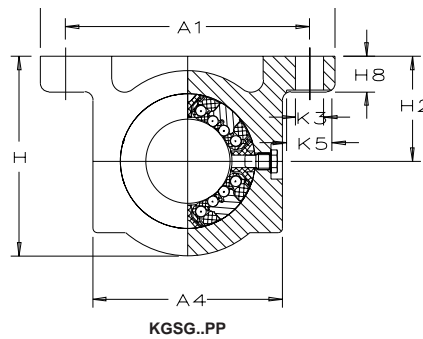

For details on part numbers, descriptive suffixes and various technical references, please refer to front of this section.
For engineering or technical information contact your local sales representative or call Distributor Sales (800)523-6572.

DIMENSION TABLE • Dimensions in mm

SHAFT DIAMETER d	PART NUMBER	MASS =kg	DIMENSIONS				MOUNTING DIMENSIONS		
			d	A	C	H	A ₁ ±0.15	A ₄	A ₆ ¹⁾
12	KGSG 12 PP	0.08	12	52	32	35.8	42	31.6	-
	KGSS 12 PP	0.08	12	52	32	35.8	42	31.6	-
	KGSO 12 PP	0.07	12	52	32	-	42	31.6	7.6
16	KGSG 16 PP	0.13	16	56	36	37.5	46	35	-
	KGSS 16 PP	0.13	16	56	36	37.5	46	35	-
	KGSO 16 PP	0.12	16	56	36	-	46	35	10.1
20	KGSG 20 PP	0.27	20	70	45	47.5	58	45	-
	KGSS 20 PP	0.27	20	70	45	47.5	58	45	-
	KGSO 20 PP	0.23	20	70	45	-	58	45	10
25	KGSG 25 PP	0.51	25	80	58	57.5	68	55	-
	KGSS 25 PP	0.51	25	80	58	57.5	68	55	-
	KGSO 25 PP	0.44	25	80	58	-	68	55	12.5
30	KGSG 30 PP	0.83	30	88	68	66.5	76	63	-
	KGSS 30 PP	0.83	30	88	68	66.5	76	63	-
	KGSO 30 PP	0.73	30	88	68	-	76	63	13.6
40	KGSG 40 PP	1.21	40	108	80	83.5	94	77	-
	KGSS 40 PP	1.21	40	108	80	83.5	94	77	-
	KGSO 40 PP	1.05	40	108	80	-	94	77	18.2
50	KGSG 50 PP	2.53	50	135	100	98	116	96	-
	KGSS 50 PP	2.53	50	135	100	98	116	96	-
	KGSO 50 PP	1.98	50	135	100	-	116	96	22.7

1) Dimensions A₆ on diameter d.

2) For fixing screws to EN ISO 4762-8.8.

If there is a possibility of settling, the fixing screws should be secured against rotation.

3) The basic load ratings apply only to hardened (670 to 840 HV) and ground shaft raceways.

Basic load ratings in accordance with DIN 636-1.

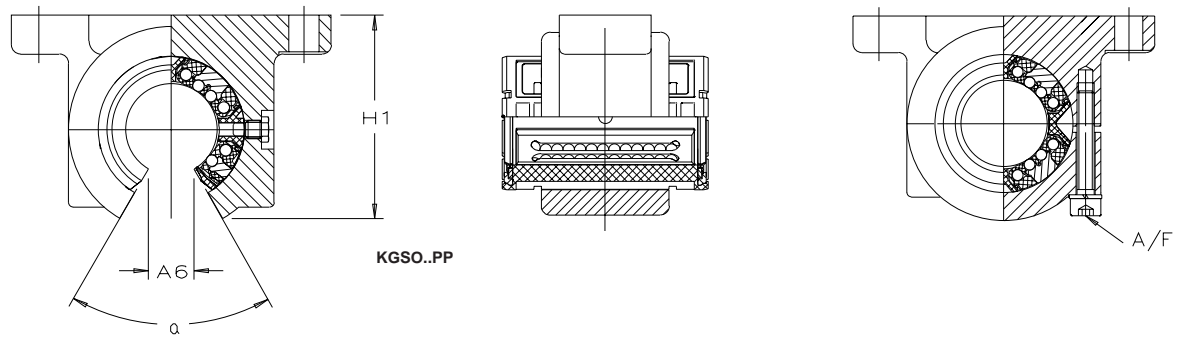

DIMENSION TABLE • Dimensions in mm

MOUNTING DIMENSIONS										BALL ROWS QUANTITY	BASIC LOAD RATINGS ³⁾		SHAFT DIAMETER
C ₁	C ₃	D	H ₁	H ₂ ±0.015	H ₈	K ₂ ²⁾	K ₅ ²⁾	α Degrees	A/F		dyn. C _{max} N	stat. C _{0max} N	
20	12	22	-	20	6	5.5	10	-	-	8	900	810	12
20	12	22	-	20	6	5.5	10	-	2	8	900	810	
20	12	22	32.3	20	6	5.5	10	78	-	6	900	810	
22	15	26	-	20	6	5.5	10	-	-	8	1,430	1,160	16
22	15	26	-	20	6	5.5	10	-	2	8	1,430	1,160	
22	15	26	33.6	20	6	5.5	10	78	-	6	1,430	1,160	
28	20	32	-	25	8	6.6	11	-	-	8	2,200	1,730	20
28	20	32	-	25	8	6.6	11	-	3	8	2,200	1,730	
28	20	32	44.5	25	8	6.6	11	60	-	6	2,200	1,730	
40	28	40	-	30	10	6.6	11	-	-	8	3,950	3,250	25
40	28	40	-	30	10	6.6	11	-	3	8	3,950	3,250	
40	28	40	53.8	30	10	6.6	11	60	-	6	3,950	3,250	
48	32	47	-	35	10	6.6	11	-	-	8	5,900	4,500	30
48	32	47	-	35	10	6.6	11	-	4	8	5,900	4,500	
48	32	47	63.1	35	10	6.6	11	54	-	6	5,900	4,500	
56	40	62	-	45	12	9	15	-	-	8	10,200	7,200	40
56	40	62	-	45	12	9	15	-	4	8	10,200	7,200	
56	40	62	79.3	45	12	9	15	54	-	6	10,200	7,200	
72	52	75	-	50	14	11	18	-	-	8	15,100	10,400	50
72	52	75	-	50	14	11	18	-	5	8	15,100	10,400	
72	52	75	92.8	50	14	11	18	54	-	6	15,100	10,400	

Linear Ball Bearing Units

KGSAG..PP, KGSAS..PP, KGS AO..PP SERIES

- MAX³ Maximum Performance
- Closed and open designs
- Contact seals on both sides

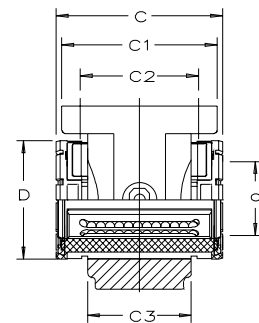
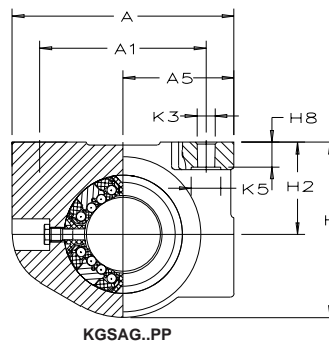

For details on part numbers, descriptive suffixes and various technical references, please refer to front of this section.
For engineering or technical information contact your local sales representative or call Distributor Sales (800)523-6572.

DIMENSION TABLE • Dimensions in mm

SHAFT DIAMETER d	PART NUMBER	MASS ≈kg	DIMENSIONS				MOUNTING DIMENSIONS		
			d	A	C	H	A ₁ ±0.15	A ₅	A _g ¹⁾
12	KGSAG 12 PP	0.06	12	42	32	34	32	21	-
	KGSAS 12 PP	0.06	12	42	32	34	32	21	-
	KGS AO 12 PP	0.05	12	42	32	-	32	21	7.6
16	KGSAG 16 PP	0.11	16	50	36	41	40	25	-
	KGSAS 16 PP	0.11	16	50	36	41	40	25	-
	KGS AO 16 PP	0.1	16	50	36	-	40	25	10.1
20	KGSAG 20 PP	0.17	20	60	45	47.5	45	30	-
	KGSAS 20 PP	0.17	20	60	45	47.5	45	30	-
	KGS AO 20 PP	0.15	20	60	45	-	45	30	10
25	KGSAG 25 PP	0.34	25	74	58	60	60	37	-
	KGSAS 25 PP	0.34	25	74	58	60	60	37	-
	KGS AO 25 PP	0.3	25	74	58	-	60	37	12.5
30	KGSAG 30 PP	0.54	30	84	68	67	68	42	-
	KGSAS 30 PP	0.54	30	84	68	67	68	42	-
	KGS AO 30 PP	0.48	30	84	68	-	68	42	13.6
40	KGSAG 40 PP	0.98	40	108	80	87	86	54	-
	KGSAS 40 PP	0.98	40	108	80	87	86	54	-
	KGS AO 40 PP	0.84	40	108	80	-	86	54	18.2
50	KGSAG 50 PP	1.63	50	130	100	98	108	65	-
	KGSAS 50 PP	1.63	50	130	100	98	108	65	-
	KGS AO 50 PP	1.17	50	130	100	-	108	65	22.7

¹⁾ Dimensions A_g on diameter d.

²⁾ For fixing screws to EN ISO 4762-8.8.

If there is a possibility of settling, the fixing screws should be secured against rotation.

³⁾ The basic load ratings apply only to hardened (670 to 840 HV) and ground shaft raceways.
Basic load ratings in accordance with DIN 636-1.

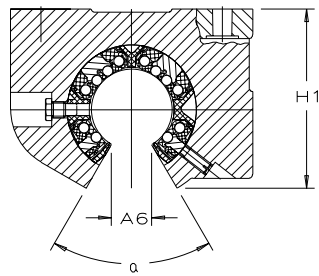

KGSAO..PP

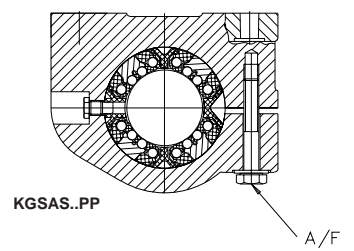
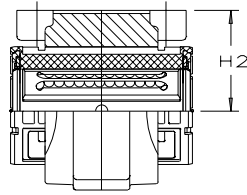

KGSAS..PP

DIMENSION TABLE • Dimensions in mm

MOUNTING DIMENSIONS											BALL ROWS	BASIC LOAD RATINGS ³⁾		SHAFT DIAMETER
C ₁	C ₂ ±0.015	C ₃	D h5	H ₁	H ₂ ±0.01	H ₈ -0.5	K ₃ ²⁾	K ₅ ²⁾	α Degrees	A/F		QUANTITY	dyn. C _{max} N	
32	23	20	22	-	18	4.8	4.7	8	-	-	8	900	810	12
32	23	20	22	-	18	4.8	4.7	8	-	7	8	900	810	12
32	23	20	22	30.4	18	4.8	4.7	8	78	-	6	900	810	12
35	26	22	26	-	22	5.4	4.7	8	-	-	8	1,430	1,160	16
35	26	22	26	-	22	5.4	4.7	8	-	7	8	1,430	1,160	16
35	26	22	26	36.8	22	5.4	4.7	8	78	-	6	1,430	1,160	16
42	32	28	32	-	25	6.7	4.7	8	-	-	8	2,200	1,730	20
42	32	28	32	-	25	6.7	4.7	8	-	7	8	2,200	1,730	20
42	32	28	32	44.5	25	6.7	4.7	8	60	-	6	2,200	1,730	20
54	40	40	40	-	30	7.8	5.7	10	-	-	8	3,950	3,250	25
54	40	40	40	-	30	7.8	5.7	10	-	8	8	3,950	3,250	25
54	40	40	40	56	30	7.8	5.7	10	60	-	6	3,950	3,250	25
60	45	48	47	-	35	8.7	6.8	11	-	-	8	5,900	4,500	30
60	45	48	47	-	35	8.7	6.8	11	-	10	8	5,900	4,500	30
60	45	48	47	63.5	35	8.7	6.8	11	54	-	6	5,900	4,500	30
78	58	56	62	-	45	11	9.2	15	-	-	8	10,200	7,200	40
78	58	56	62	-	45	11	9.2	15	-	13	8	10,200	7,200	40
78	58	56	62	82.4	45	11	9.2	15	54	-	6	10,200	7,200	40
70	50	72	75	-	50	12.5	9.2	15	-	-	8	15,100	10,400	50
70	50	72	75	-	50	12.5	9.2	15	-	13	8	15,100	10,400	50
70	50	72	75	92.8	50	12.5	9.2	15	54	-	6	15,100	10,400	50

Linear Ball Bearing Units

KGSNG..PP AS, KGSNS..PP AS SERIES

- MAX³ Maximum Performance
- Light range - metric sizes
- Sealed, greased with relubrication facility

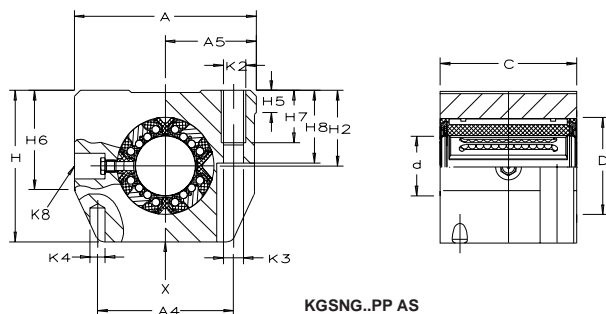

For details on part numbers, descriptive suffixes and various technical references, please refer to front of this section.

For engineering or technical information contact your local sales representative or call Distributor Sales (800)523-6572.

DIMENSION TABLE • Dimensions in mm

SHAFT DIAMETER	PART NUMBER	MASS =kg	DIMENSIONS				MOUNTING DIMENSIONS				
			d	A	C	H	A ₁ ±0.15	A ₄	A ₅ ±0.01	C ₂ ¹⁾ ±0.15	D
12	KGSNG 12 PP AS	0.1	12	43	32	35	32	34	21.5	23	22
	KGSNS 12 PP AS	0.1	12	43	32	35	32	34	21.5	23	22
16	KGSNG 16 PP AS	0.17	16	53	37	42	40	40	26.5	26	26
	KGSNS 16 PP AS	0.17	16	53	37	42	40	40	26.5	26	26
20	KGSNG 20 PP AS	0.27	20	60	45	50	45	44	30	32	32
	KGSNS 20 PP AS	0.27	20	60	45	50	45	44	30	32	32
25	KGSNG 25 PP AS	0.56	25	78	58	60	60	59.4	39	40	40
	KGSNS 25 PP AS	0.56	25	78	58	60	60	59.4	39	40	40
30	KGSNG 30 PP AS	0.83	30	87	68	70	68	63	43.5	45	47
	KGSNS 30 PP AS	0.83	30	87	68	70	68	63	43.5	45	47
40	KGSNG 40 PP AS	1.55	40	108	80	90	86	76	54	58	62
	KGSNS 40 PP AS	1.55	40	108	80	90	86	76	54	58	62
50	KGSNG 50 PP AS	2.7	50	132	100	105	108	90	66	50	75
	KGSNS 50 PP AS	2.7	50	132	100	105	108	90	66	50	75

¹⁾ Dimension C₂ and lubrication hole symmetrical with bearing width C.

²⁾ For fixing screws to EN ISO 4762-8.8.

If there is a possibility of settling, the fixing screws should be secured against rotation.

³⁾ Centring for dowel hole.

⁴⁾ The basic load ratings apply only to hardened (670 to 840

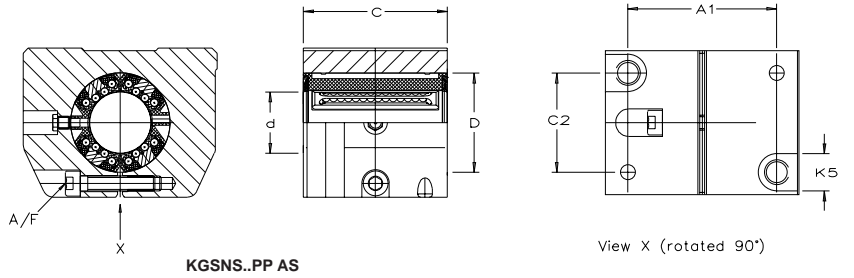

DIMENSION TABLE • Dimensions in mm														
MOUNTING DIMENSIONS											BALL ROWS QUANTITY	BASIC LOAD RATINGS ³⁾		SHAFT DIAMETER d
H ₂ +0.008 -0.016	H ₅	H ₆	H ₇	H ₈	K ₂	K ₃ ²⁾	K ₄ ³⁾	K ₅ ²⁾	K ₈ ¹⁾	A/F		dyn. C _{max} N	stat. C _{0max} N	
18	5.4	25.3	11	16.5	M 5	4.3	4	8	NIP 4 MZ	-	8	900	810	12
18	5.4	25.3	11	16.5	M 5	4.3	4	8	NIP 4 MZ	2.5	8	900	810	12
22	6.9	28	13	21	M 6	5.3	4	10	NIP 4 MZ	-	8	1,430	1,160	16
22	6.9	28	13	21	M 6	5.3	4	10	NIP 4 MZ	3	8	1,430	1,160	16
25	7.4	32.8	18	24	M 8	6.6	5	11	NIP 4 MZ	-	8	2,200	1,730	20
25	7.4	32.8	18	24	M 8	6.6	5	11	NIP 4 MZ	4	8	2,200	1,730	20
30	8.3	40	22	29	M10	8.4	6	15	NIP 5 MZ	-	8	3,950	3,250	25
30	8.3	40	22	29	M10	8.4	6	15	NIP 5 MZ	5	8	3,950	3,250	25
35	9.3	44.7	22	34	M10	8.4	6	15	NIP 5 MZ	-	8	5,900	4,500	30
35	9.3	44.7	22	34	M10	8.4	6	15	NIP 5 MZ	5	8	5,900	4,500	30
45	11.7	55.9	26	44	M12	10.5	8	18	NIP 5 MZ	-	8	10,200	7,200	40
45	11.7	55.9	26	44	M12	10.5	8	18	NIP 5 MZ	6	8	10,200	7,200	40
50	10.6	60	35	49	M16	13.5	10	20	NIP 6 MZ	-	8	15,100	10,400	50
50	10.6	60	35	49	M16	13.5	10	20	NIP 6 MZ	8	8	15,100	10,400	50

Linear Ball Bearing Units

KGSNO..PP AS, KGSNOS..PP AS SERIES

- MAX³ Maximum Performance
- Light range - metric sizes
- Sealed, greased with relubrication facility

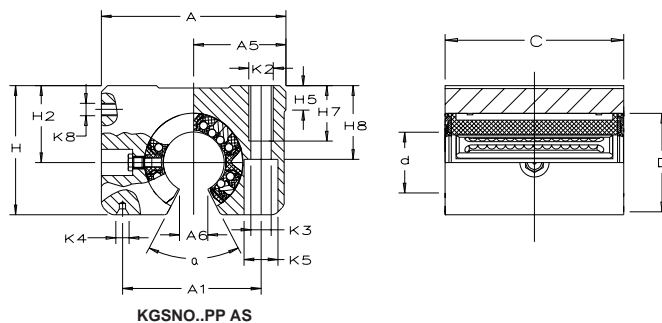

For details on part numbers, descriptive suffixes and various technical references, please refer to front of this section.
 For engineering or technical information contact your local sales representative or call Distributor Sales (800)523-6572.

DIMENSION TABLE • Dimensions in mm

SHAFT DIAMETER d	PART NUMBER	MASS =kg	DIMENSIONS				MOUNTING DIMENSIONS				
			d	A	C	H	A ₁ ±0.15	A ₅ ±0.01	A ₆ ¹⁾	C ₂ ²⁾ ±0.15	D
12	KGSNO 12 PP AS	0.09	12	43	32	28	32	21.5	7.6	23	22
	KGSNOS 12 PP AS	0.09	12	43	32	28	32	21.5	7.6	23	22
16	KGSNO 16 PP AS	0.15	16	53	37	35	40	26.5	8.9	26	26
	KGSNOS 16 PP AS	0.15	16	53	37	35	40	26.5	8.9	26	26
20	KGSNO 20 PP AS	0.25	20	60	45	42	45	30	9.2	32	32
	KGSNOS 20 PP AS	0.25	20	60	45	42	45	30	9.2	32	32
25	KGSNO 25 PP AS	0.52	25	78	58	51	60	39	11.9	40	40
	KGSNOS 25 PP AS	0.52	25	78	58	51	60	39	11.9	40	40
30	KGSNO 30 PP AS	0.76	30	87	68	60	68	43.5	14.3	45	47
	KGSNOS 30 PP AS	0.76	30	87	68	60	68	43.5	14.3	45	47
40	KGSNO 40 PP AS	1.4	40	108	80	77	86	54	18.8	58	62
	KGSNOS 40 PP AS	1.4	40	108	80	77	86	54	18.8	58	62
50	KGSNO 50 PP AS	2.4	50	132	100	88	108	66	22.7	50	75
	KGSNOS 50 PP AS	2.4	50	132	100	88	108	66	22.7	50	75

- 1) Dimension A₆ on diameter C.
- 2) Dimension C₂ and lubrication hole symmetrical with bearings width C.
- 3) For fixing screws to EN ISO 4762-8.8.
If there is a possibility of settling, the fixing screws should be secured against rotation.
- 4) The basic load ratings apply only to hardened (670 to 840 HV) and ground shaft raceways.
- 5) Centring hole to DIN 332, type A.



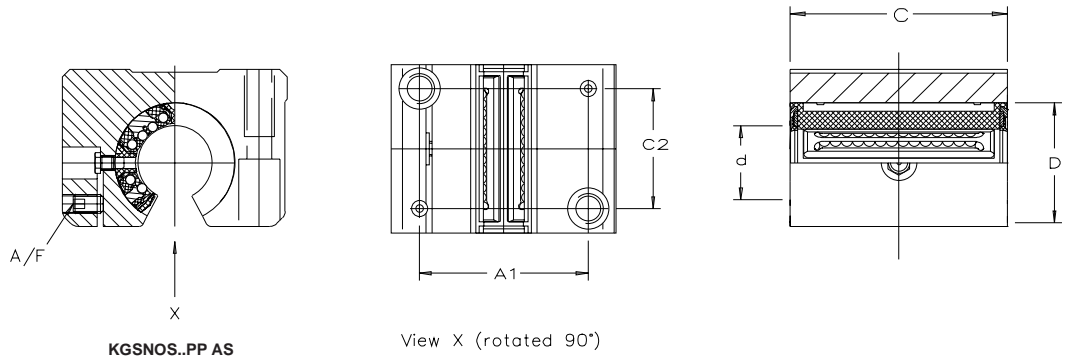

DIMENSION TABLE • Dimensions in mm														
MOUNTING DIMENSIONS											BALL ROWS QUANTITY	BASIC LOAD RATINGS ³⁾		SHAFT DIAMETER d
H ₂ +0.008 -0.016	H ₅	H ₇	H ₈	K ₂	K ₃ ³⁾	K ₄ ⁵⁾	K ₅ ³⁾	K ₈ ²⁾	A/F	α Degrees		dyn. C _{max} N	stat. C _{0max} N	
18	6.1	11	16.5	M 5	4.3	1.6 x 3.35	8	NIP 4 MZ	-	78	6	900	810	12
18	6.1	11	16.5	M 5	4.3	1.6 x 3.35	8	NIP 4 MZ	2.5	78	6	900	810	12
22	7.5	13	21	M 6	5.3	1.6 x 3.35	10	NIP 4 MZ	-	68	6	1,430	1,160	16
22	7.5	13	21	M 6	5.3	1.6 x 3.35	10	NIP 4 MZ	2.5	68	6	1,430	1,160	16
25	8	18	24	M 8	6.6	2 x 4.25	11	NIP 4 MZ	-	55	6	2,200	1,730	20
25	8	18	24	M 8	6.6	2 x 4.25	11	NIP 4 MZ	2.5	55	6	2,200	1,730	20
30	8.8	22	29	M10	8.4	2.5 x 5.3	15	NIP 5 MZ	-	57	6	3,950	3,250	25
30	8.8	22	29	M10	8.4	2.5 x 5.3	15	NIP 5 MZ	3	57	6	3,950	3,250	25
35	9.7	22	34	M10	8.4	2.5 x 5.3	15	NIP 5 MZ	-	57	6	5,900	4,500	30
35	9.7	22	34	M10	8.4	2.5 x 5.3	15	NIP 5 MZ	3	57	6	5,900	4,500	30
45	12.4	26	44	M12	10.5	3.15 x 6.7	18	NIP 5 MZ	-	56	6	10,200	7,200	40
45	12.4	26	44	M12	10.5	3.15 x 6.7	18	NIP 5 MZ	4	56	6	10,200	7,200	40
50	11.1	35	49	M16	13.5	4 x 8.5	20	NIP 6 MZ	-	54	6	15,100	10,400	50
50	11.1	35	49	M16	13.5	4 x 8.5	20	NIP 6 MZ	5	54	6	15,100	10,400	50

Linear Ball Bearing Units KTSG..PP AS, KTSS..PP AS SERIES

- MAX³ Maximum Performance
- Closed and open designs
- Contact seals on both sides

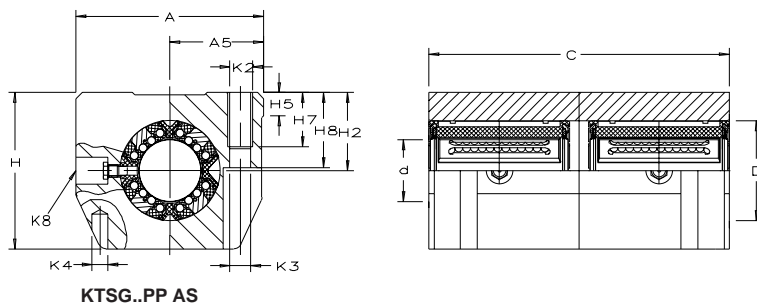

For details on part numbers, descriptive suffixes and various technical references, please refer to front of this section.
For engineering or technical information contact your local sales representative or call Distributor Sales (800)523-6572.

DIMENSION TABLE • Dimensions in mm

SHAFT DIAMETER d	PART NUMBER	MASS -kg	DIMENSIONS				MOUNTING DIMENSIONS				
			d	A	C	H	A ₁ ±0.15	A ₅ ±0.01	C ₂ ¹⁾ ±0.15	C ₃ ¹⁾	D
12	KTSG 12 PP AS	0.21	12	43	70	35	32	21.5	56	24	22
	KTSS 12 PP AS	0.21	12	43	70	35	32	21.5	56	24	22
16	KTSG 16 PP AS	0.38	16	53	78	42	40	26.5	64	26	26
	KTSS 16 PP AS	0.38	16	53	78	42	40	26.5	64	26	26
20	KTSG 20 PP AS	0.55	20	60	96	50	45	30	76	33	32
	KTSS 20 PP AS	0.55	20	60	96	50	45	30	76	33	32
25	KTSG 25 PP AS	1.13	25	78	122	60	60	39	94	44	40
	KTSS 25 PP AS	1.13	25	78	122	60	60	39	94	44	40
30	KTSG 30 PP AS	1.78	30	87	142	70	68	43.5	106	54	47
	KTSS 30 PP AS	1.78	30	87	142	70	68	43.5	106	54	47

- 1) Dimensions and lubrication hole symmetrical with bearing width C.
- 2) For fixing screws to EN ISO 4762-8.8.
If there is a possibility of settling, the fixing screws should be secured against rotation.
- 3) Centring for dowel hole.
- 4) Lubrication nipple.
- 5) The basic load ratings apply only to hardened (670 to 840 HV) and ground shaft raceways.
Basic load ratings in accordance with DIN 636-1.



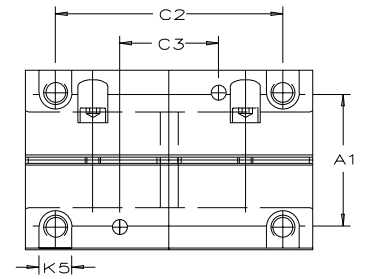
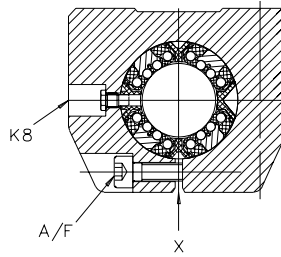

KTSS..PP AS
(same dimensions as KTSG..PP AS)

View X (rotated 90°)

DIMENSION TABLE • Dimensions in mm														
MOUNTING DIMENSIONS											BALL ROWS QUANTITY	BASIC LOAD RATINGS ³⁾		SHAFT DIAMETER d
H ₂ +0.008 -0.016	H ₅	H ₆	H ₇	H ₈	K ₂	K ₃ ²⁾	K ₄ ³⁾	K ₅ ²⁾	K ₆ ⁴⁾	A/F		dyn. C _{max} N	stat. C _{0max} N	
18	6	25.3	11	16.5	M 5	4.3	4	8	NIP 4 MZ	-	8	1,460	1,620	12
18	6	25.3	11	16.5	M 5	4.3	4	8	NIP 4 MZ	2.5	8	1,460	1,620	12
22	7.5	28	13	21	M 6	5.3	4	10	NIP 4 MZ	-	8	2,330	2,320	16
22	7.5	28	13	21	M 6	5.3	4	10	NIP 4 MZ	3	8	2,330	2,320	16
25	8	32.8	18	24	M 8	6.6	5	11	NIP 4 MZ	-	8	3,650	3,450	20
25	8	32.8	18	24	M 8	6.6	5	11	NIP 4 MZ	4	8	3,650	3,450	20
30	9	40	22	29	M10	8.4	6	15	NIP 5 MZ	-	8	6,400	6,500	25
30	9	40	22	29	M10	8.4	6	15	NIP 5 MZ	5	8	6,400	6,500	25
35	10	44.7	22	34	M10	8.4	6	15	NIP 5 MZ	-	8	9,600	9,000	30
35	10	44.7	22	34	M10	8.4	6	15	NIP 5 MZ	5	8	9,600	9,000	30

Linear Ball Bearing Units

KTSO..PP AS, KTSOS..PP AS SERIES

- MAX³ Maximum Performance
- Open design
- Contact seals on both sides

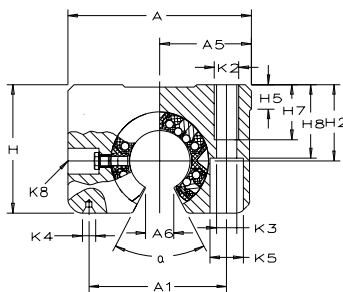

KTSO..PP AS

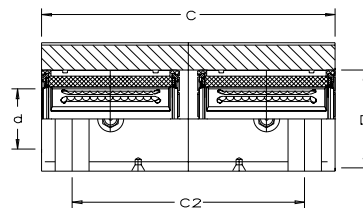

For details on part numbers, descriptive suffixes and various technical references, please refer to front of this section.
 For engineering or technical information contact your local sales representative or call Distributor Sales (800)523-6572.

DIMENSION TABLE • Dimensions in mm

SHAFT DIAMETER d	PART NUMBER	MASS =kg	DIMENSIONS				MOUNTING DIMENSIONS					
			d	A	C	H	A ₁ ±0.15	A ₅ ±0.01	A ₆ ¹⁾	C ₂ ²⁾ ±0.15	C ₃ ²⁾	D
12	KTSO 12 PP AS	0.118	12	43	70	28	32	21.5	6.5	56	24	22
	KTSOS 12 PP AS	0.18	12	43	70	28	32	21.5	6.5	56	24	22
16	KTSO 16 PP AS	0.34	16	53	78	35	40	26.5	8.9	64	26	26
	KTSOS 16 PP AS	0.34	16	53	78	35	40	26.5	8.9	64	26	26
20	KTSO 20 PP AS	0.51	20	60	96	42	45	30	9.2	76	33	32
	KTSOS 20 PP AS	0.51	20	60	96	42	45	30	9.2	76	33	32
25	KTSO 25 PP AS	1.03	25	78	122	51	60	39	11.9	94	44	40
	KTSOS 25 PP AS	1.03	25	78	122	51	60	39	11.9	94	44	40
30	KTSO 30 PP AS	1.8	30	87	142	60	68	43.5	14.3	106	54	47
	KTSOS 30 PP AS	1.8	30	87	142	60	68	43.5	14.3	106	54	47

- 1) Dimensions A₆ on diameter d.
- 2) Dimensions and lubrication hole symmetrical with bearing width C.
- 3) For fixing screws to EN ISO 4762-8.8.
If there is a possibility of settling, the fixing screws should be secured against rotation.
- 4) Lubrication nipple.
- 5) The basic load ratings apply only to hardened (670 to 840 HV) and ground shaft raceways.
Basic load ratings in accordance with DIN 636-1.
- 6) Centring hole to DIN 332, type A.



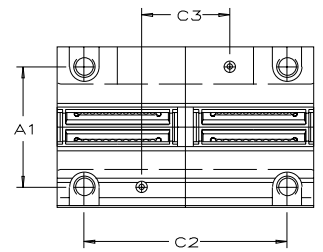
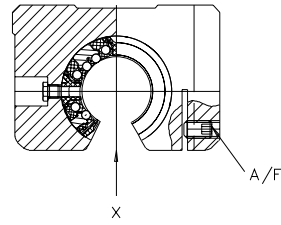

KTSOS..PP AS
(Same dimensions as KTSO..PP AS)

View X (rotated 90°)

DIMENSION TABLE • Dimensions in mm														
MOUNTING DIMENSIONS											BALL ROWS QUANTITY	BASIC LOAD RATINGS ³⁾		SHAFT DIAMETER d
H ₂ +0.008 -0.016	H ₅	H ₇	H ₈	K ₂	K ₃ ³⁾	K ₄ ⁶⁾	K ₅ ³⁾	K ₈ ⁴⁾	A/F	α Degrees		dyn. C _{max} N	stat. C _{0max} N	
18	6.1	11	16.5	M 5	4.3	1.6 x 3.35	8	NIP 4 MZ	-	66	6	1,460	1,620	12
18	6.1	11	16.5	M 5	4.3	1.6 x 3.35	8	NIP 4 MZ	2.5	66	6	1,460	1,620	
22	7.5	13	21	M 6	5.3	1.6 x 3.35	10	NIP 4 MZ	-	68	6	2,330	2,320	16
22	7.5	13	21	M 6	5.3	1.6 x 3.35	10	NIP 4 MZ	2.5	68	6	2,330	2,320	
25	8	18	24	M 8	6.6	2.0 x 4.25	11	NIP 4 MZ	-	55	6	3,650	3,450	20
25	8	18	24	M 8	6.6	2.0 x 4.25	11	NIP 4 MZ	2.5	55	6	3,650	3,450	
30	8.8	22	29	M10	8.4	2.5 x 5.3	15	NIP 5 MZ	-	57	6	6,400	6,500	25
30	8.8	22	29	M10	8.4	2.5 x 5.3	15	NIP 5 MZ	3	57	6	6,400	6,500	
35	9.7	22	34	M10	8.4	2.5 x 5.3	15	NIP 5 MZ	-	57	6	9,600	9,000	30
35	9.7	22	34	M10	8.4	2.5 x 5.3	15	NIP 5 MZ	3	57	6	9,600	9,000	

Linear Ball Bearing Units

KGSC..PP AS, KGSCS..PP AS SERIES

- MAX³ Maximum Performance
- Light range - metric sizes
- Sealed, greased with relubrication facility

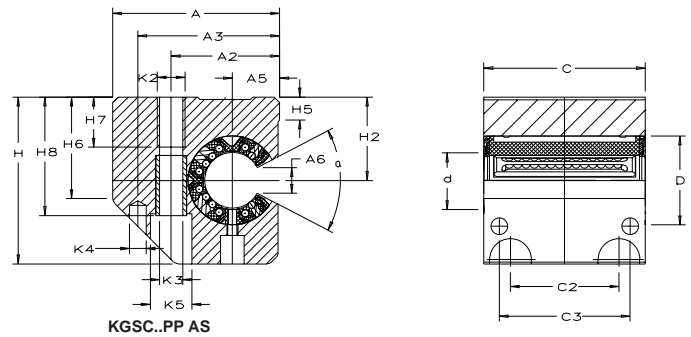

For details on part numbers, descriptive suffixes and various technical references, please refer to front of this section.
 For engineering or technical information contact your local sales representative or call Distributor Sales (800)523-6572.

DIMENSION TABLE • Dimensions in mm

SHAFT DIAMETER d	PART NUMBER	MASS =kg	DIMENSIONS					MOUNTING DIMENSIONS				
			d	A	C	H	A ₂ ±0.15	A ₃	A ₅ ±0.01	A ₆ ¹⁾	C ₂ ²⁾ ±0.15	C ₃ ²⁾
20	KGSC 20 PP AS	0.35	20	60	47	60	39	51	17	9.2	30	36
	KGSCS 20 PP AS	0.35	20	60	47	60	39	51	17	9.2	30	36
25	KGSC 25 PP AS	0.68	25	75	58	72	49	64	21	12	36	45
	KGSCS 25 PP AS	0.68	25	75	58	72	49	64	21	12	36	45
30	KGSC 30 PP AS	1	30	86	68	82	59	76	25	14.3	42	52
	KGSCS 30 PP AS	1	30	86	68	82	59	76	25	14.3	42	52
40	KGSC 40 PP AS	1.8	40	110	80	100	75	97	32	18.8	48	60
	KGSCS 40 PP AS	1.8	40	110	80	100	75	97	32	18.8	48	60
50	KGSC 50 PP AS	2.9	50	127	100	115	88	109	38	22.7	62	80
	KGSCS 50 PP AS	2.9	50	127	100	115	88	109	38	22.7	62	80

- 1) Dimension A₆ on diameter d.
- 2) Dimension C₂ and lubrication hole symmetrical with bearing width C.
- 3) Centring for dowel hole.
- 4) For fixing screws to EN ISO 4762-8.8.
If there is a possibility of settling, the fixing screws should be secured against rotation.
- 5) The basic load ratings apply only to hardened (670 to 840 HV) and ground shaft raceways.



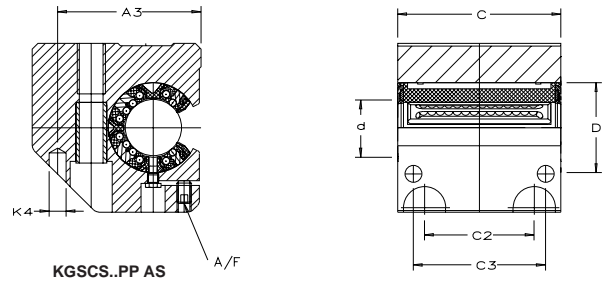

DIMENSION TABLE • Dimensions in mm																
D	MOUNTING DIMENSIONS											BALL ROWS QUANTITY	BASIC LOAD RATINGS ³⁾		SHAFT DIAMETER d	
	H ₂ +0.008 -0.016	H ₅	H ₆	H ₇	H ₈	K ₂	K ₃ ³⁾	K ₄ ⁴⁾	K ₅ ³⁾	K ₆ ²⁾	A/F		α Degrees	dyn. C _{max} N		stat. C _{0max} N
32	30	8.3	37.5	18	42.6	M10	8.4	6	15	NIP 4 MZ	-	55	6	2,200	1,730	20
32	30	8.3	37.5	18	42.6	M10	8.4	6	15	NIP 4 MZ	2.5	55	6	2,200	1,730	20
40	35	8.2	45	22	50.6	M12	10.5	8	18	NIP 5 MZ	-	57	6	3,950	3,250	25
40	35	8.2	45	22	50.6	M12	10.5	8	18	NIP 5 MZ	3	57	6	3,950	3,250	25
47	40	9	52	29	55.6	M16	13.5	10	20	NIP 5 MZ	-	57	6	5,900	4,500	30
47	40	9	52	29	55.6	M16	13.5	10	20	NIP 5 MZ	3	57	6	5,900	4,500	30
62	45	9.5	60	36	67.6	M20	15.5	12	24	NIP 5 MZ	-	56	6	10,200	7,200	40
62	45	9.5	60	36	67.6	M20	15.5	12	24	NIP 5 MZ	4	56	6	10,200	7,200	40
75	50	8.6	70	36	78.8	M20	17.5	12	26	NIP 6 MZ	-	54	6	15,100	10,400	50
75	50	8.6	70	36	78.8	M20	17.5	12	26	NIP 6 MZ	5	54	6	15,100	10,400	50

Linear Ball Bearing Units

KTFS..PP AS SERIES

- MAX³ Maximum Performance
- Light range - metric sizes
- Sealed, greased with relubrication facility

For details on part numbers, descriptive suffixes and various technical references, please refer to front of this section.

For engineering or technical information contact your local sales representative or call Distributor Sales (800)523-6572.

DIMENSION TABLE • Dimensions in mm

SHAFT DIAMETER d	PART NUMBER	MASS =kg	DIMENSIONS				MOUNTING DIMENSIONS				
			d	A	C	H	A ₁ ±0.15	C ₁	C ₃	C ₇	D
12	KTFS 12 PP AS	0.2	12	41	70	34	32	40	10	35	22
16	KTFS 16 PP AS	0.3	16	50	78	40	38	50	10	39	26
20	KTFS 20 PP AS	0.5	20	60	96	50	45	60	10	48	32
25	KTFS 25 PP AS	1	25	74	122	60	56	73	10	61	40
30	KTFS 30 PP AS	1.4	30	84	142	70	64	82	10	71	47

¹⁾ Recommendation: locating bore D, H7.

²⁾ The basic load ratings apply only to hardened (670 to 840 HV) and ground shaft raceways.



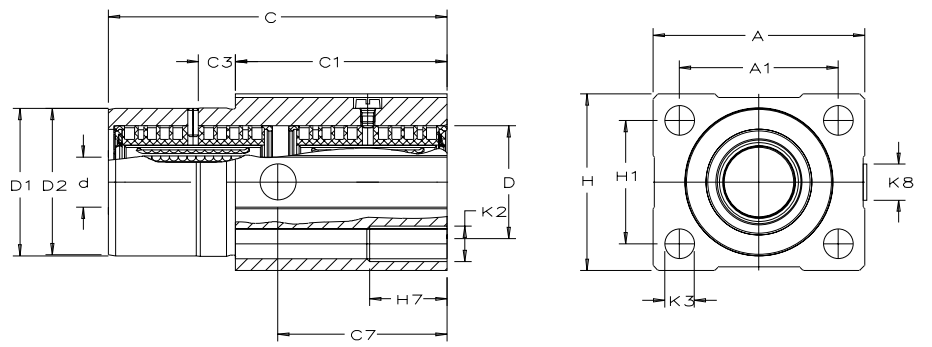

KTFS..PP AS

DIMENSION TABLE • Dimensions in mm										
MOUNTING DIMENSIONS							BALL ROWS QUANTITY	BASIC LOAD RATINGS ³⁾		SHAFT DIAMETER d
D ₁ ¹⁾ g7	D ₂ -0.1 -0.3	H ₁ ±0.15	H ₇	K ₂	K ₃	K ₈		dyn. C _{rmax} N	stat. C _{0max} N	
30	30	24	13	M 6	5.3	M8x1	8	1,460	1,620	12
35	35	28	18	M 8	6.6	M8x1	8	2,330	2,320	16
42	42	35	22	M10	8.4	M8x1	8	3,650	3,450	20
52	52	42	26	M12	10.5	M8x1	8	6,400	6,500	25
61	61	50	35	M16	13.5	M8x1	8	9,600	9,000	30

Linear Ball Bearings

KH SERIES

- Compact Range
- With Relubrication Facility

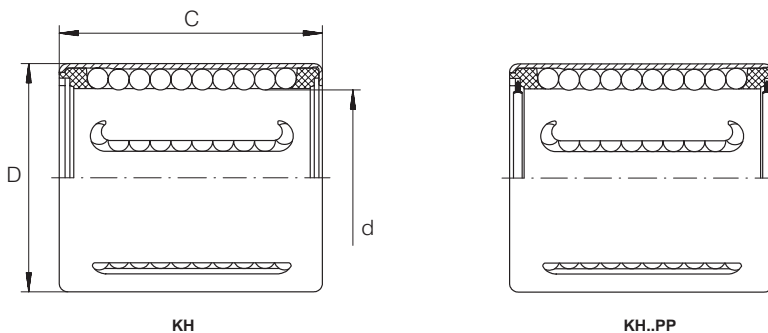

For details on part numbers, descriptive suffixes and various technical references, please refer to front of this section.

For engineering or technical information contact your local sales representative or call Distributor Sales (800)523-6572 or Linear Sales (800)462-3399.

DIMENSION TABLE - Dimensions in mm

SHAFT DIA.	PART NUMBER ¹⁾	MASS g	DIMENSIONS			MOUNTING DIMENSIONS		BASIC LOAD RATINGS ²⁾			
			d	D	C	C ₇	K ₈	dyn. C _{0 min} N	stat. C _{0 min} N	dyn. C _{0 max} N	stat. C _{0 max} N
6	KH 0622	7	6	12	22	4	2	340	239	390	340
8	KH 0824	12	8	15	24	6	2	410	280	475	400
10	KH 1026	14.5	10	17	26	6	2.5	510	370	590	520
12	KH 1228	18.5	12	19	28	6	2.5	670	510	800	740
14	KH 1428	20.5	14	21	28	6	2.5	690	520	830	760
16	KH 1630	27.5	16	24	30	7	2.5	890	620	1,060	910
20	KH 2030	32.5	20	28	30	7	2.5	1,110	790	1,170	1,010
25	KH 2540	66	25	35	40	8	2.5	2,280	1,670	2,420	2,130
30	KH 3050	95	30	40	50	8	2.5	3,300	2,700	3,300	3,100
40	KH 4060	182	40	52	60	9	2.5	5,300	4,450	5,300	4,950
50	KH 5070	252	50	62	70	9	2.5	6,800	6,300	6,800	7,000

1) Linear ball bearings sealed on both sides: suffix "PP".

2) The basic load ratings are only valid for hardened (670 to 840 HV) and ground shaft raceways.

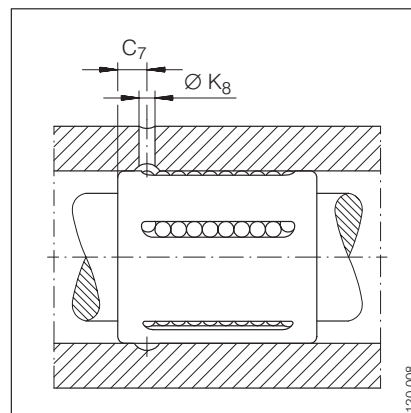

120 008



Linear Ball Bearing And Housing Units KGHK..B PP AS SERIES

- Compact Range
- Sealed, Greased, With Relubrication Facility

For details on part numbers, descriptive suffixes and various technical references, please refer to front of this section.

For engineering or technical information contact your local sales representative or call Distributor Sales (800)523-6572 or Linear Sales (800)462-3399.

DIMENSION TABLE - Dimensions in mm									
SHAFT DIAMETER	PART NUMBER	MASS kg	DIMENSIONS				MOUNTING DIMENSIONS		
			d	A	C	H	A ₁ ± 0.15	A ₄	C ₇
6	KGHK 06 B PP AS	0.04	6	32	22	27	23	25	4
8	KGHK 08 B PP AS	0.05	8	32	24	27	23	25	5
10	KGHK 10 B PP AS	0.07	10	40	26	33	29	32	5
12	KGHK 12 B PP AS	0.08	12	40	28	33	29	32	5.5
14	KGHK 14 B PP AS	0.1	14	43	28	36.5	34	34	5.5
16	KGHK 16 B PP AS	0.11	16	43	30	36.5	34	34	6
20	KGHK 20 B PP AS	0.15	20	53	30	42.5	40	40	6
25	KGHK 25 B PP AS	0.27	25	60	40	52.5	48	44	8
30	KGHK 30 B PP AS	0.4	30	67	50	60	53	49.5	9
40	KGHK 40 B PP AS	0.75	40	87	60	73.5	69	63	10
50	KGHK 50 B PP AS	1.25	50	103	70	92	82	74	12

1) For fixing screws to DIN 912-8.8 and spring washer to DIN 7980.

2) Lubrication nipple.

3) The basic load ratings are only valid for hardened (670 to 840 HV) and ground shaft raceways.



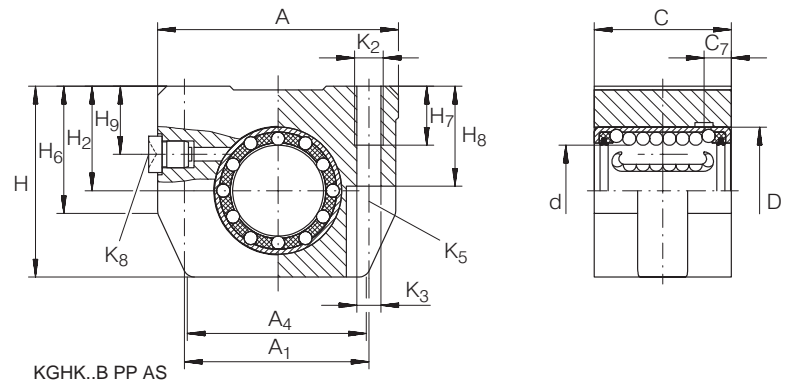

D	H ₂ +0.010 -0.014	H ₆	H ₇	H ₈	H ₉	K ₂	K ₃ ¹⁾	K ₅ ¹⁾	K ₈ ²⁾	BASIC LOAD RATINGS ³⁾		SHAFT DIAMETER
										dyn. C N	stat. C ₀ N	
12	13	19.5	9	13	9	M4	3.4	M3	NIP A1	340	239	6
15	14	19.5	9	13	9	M4	3.4	M3	NIP A1	410	280	8
17	16	24	11	16	11	M5	4.3	M4	NIP A1	510	370	10
19	17	24	11	16	11	M5	4.3	M4	NIP A1	670	510	12
21	18	26.8	11	18	13	M5	4.3	M4	NIP A1	690	520	14
24	19	26.8	11	18	13	M5	4.3	M4	NIP A1	890	620	16
28	23	28.5	13	22	15	M6	5.3	M5	NIP A2	1,110	790	20
35	27	35.5	18	26	17.5	M8	6.6	M6	NIP A2	2,280	1,670	25
40	30	41.5	18	29	18	M8	6.6	M6	NIP A2	3,300	2,700	30
52	39	48	22	38	23	M10	8.4	M8	NIP A2	5,300	4,450	40
62	47	61	26	46	28	M12	10.5	M10	NIP A2	6,800	6,300	50

Linear Ball Bearing And Housing Units KTHK..B PP AS SERIES

- Compact Range
- Sealed, Greased, With Relubrication Facility

For details on part numbers, descriptive suffixes and various technical references, please refer to front of this section.

For engineering or technical information contact your local sales representative or call Distributor Sales (800)523-6572 or Linear Sales (800)462-3399.

DIMENSION TABLE - Dimensions in mm									
SHAFT DIAMETER	PART NUMBER	MASS kg	DIMENSIONS				MOUNTING DIMENSIONS		
			d	A	C	H	A ₁ ± 0.15	A ₄	C ₂ ¹⁾ ± 0.15
12	KTHK 12 B PP AS	0.17	12	40	60	33	29	32	35
16	KTHK 16 B PP AS	0.23	16	43	65	36.5	34	34	40
20	KTHK 20 B PP AS	0.32	20	53	65	42.5	40	40	45
25	KTHK 25 B PP AS	0.58	25	60	85	52.5	48	44	55
30	KTHK 30 B PP AS	0.85	30	67	105	60	53	49.6	70
40	KTHK 40 B PP AS	1.6	40	87	125	73.5	69	63	85
50	KTHK 50 B PP AS	2.7	50	103	145	92	82	74	100

- 1) Dimension C₂ and lubrication hole centered on bearing width C.
- 2) For fixing screws to DIN 912-8.8 and spring washer to DIN 7 980.
- 3) Lubrication nipple.
- 4) The basic load ratings are only valid for hardened (670 to 840 HV) and ground shaft raceways and uniform loading on both the linear ball bearings.



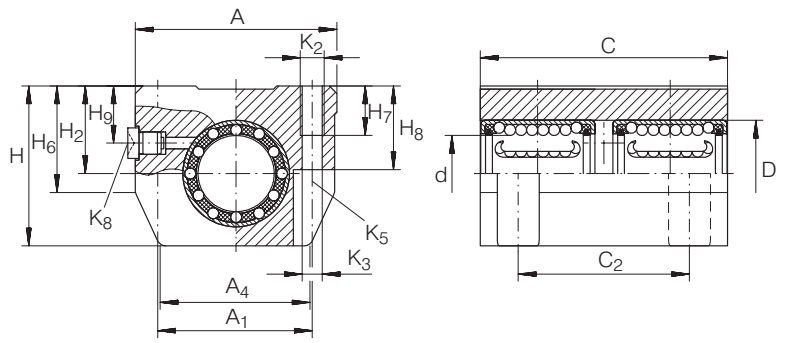

KTHK..B PP AS

D	H ₂ +0.010 -0.014	H ₆	H ₇	H ₈	H ₉	K ₂	K ₃ ²⁾	K ₅ ²⁾	K ₈ ³⁾	BASIC LOAD RATINGS ⁴⁾		SHAFT DIAMETER
										dyn. C N	stat. C ₀ N	
19	17	24	11	16	11	M5	4.3	M4	NIP A1	1,090	1,020	12
24	19	26.8	11	18	13	M5	4.3	M4	NIP A1	1,440	1,240	16
28	23	28.5	13	22	15	M6	5.3	M5	NIP A2	1,800	1,580	20
35	27	35.5	18	26	17.5	M8	6.6	M6	NIP A2	3,700	3,350	25
40	30	41.5	18	29	18	M8	6.6	M6	NIP A2	5,400	5,400	30
52	39	48	22	38	22	M10	8.4	M8	NIP A2	8,600	8,900	40
62	47	61	26	46	26	M12	10.5	M10	NIP M8x1	11,000	12,600	50

Linear Ball Bearing And Housing Units KGHW..PP SERIES

- Adjusting Range
- Sealed, Greased

For details on part numbers, descriptive suffixes and various technical references, please refer to front of this section.

For engineering or technical information contact your local sales representative or call Distributor Sales (800)523-6572 or Linear Sales (800)462-3399.

DIMENSION TABLE - Dimensions in mm						
SHAFT DIAMETER	PART NUMBER	MASS kg	DIMENSIONS			
			d	A ± 0.5	C	H
16	KGHW 16 PP	0.2	16	85.7	30	43.2
20	KGHW 20 PP	0.25	20	85.7	30	43.2
25	KGHW 25 PP	0.39	25	108	40	56.5

1) The basic load ratings are only valid for hardened (670 to 840 HV) and ground shaft raceways.



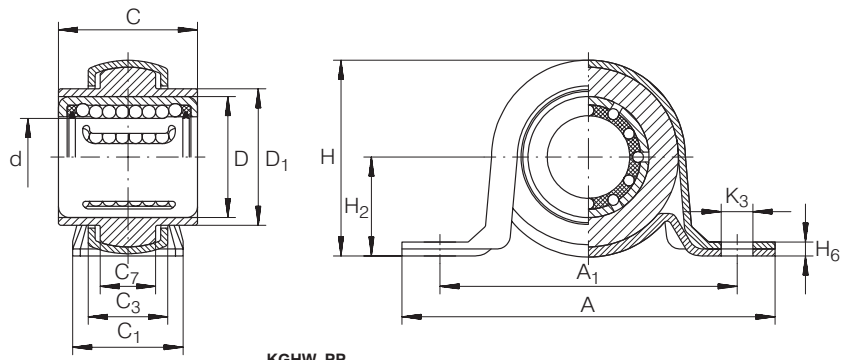

KGHW..PP

MOUNTING DIMENSIONS									BASIC LOAD RATINGS ¹⁾		SHAFT DIAMETER
A ₁ ± 0.25	C ₁	C ₃	C ₇	D	D ₁	H ₂ ± 0.2	H ₆	K ₃	dyn. C N	stat. C ₀ N	
68.3	25.4	18.8	13.2	24	32	22.2	3	9.5	890	620	16
68.3	25.4	18.8	13.2	28	32	22.2	3	9.5	1,110	790	20
86	32	23.5	14.5	35	39.5	28.6	4	11.5	2,280	1,670	25

Linear Ball Bearing And Housing Units KGHWT..PP SERIES

- Adjusting Range
- Sealed, Greased

For details on part numbers, descriptive suffixes and various technical references, please refer to front of this section.

For engineering or technical information contact your local sales representative or call Distributor Sales (800)523-6572 or Linear Sales (800)462-3399.

DIMENSION TABLE · Dimensions in mm						
SHAFT DIAMETER	PART NUMBER	MASS kg	DIMENSIONS			
			d	A	C	H
16	KGHWT 16 PP	0.19	16	81	30	58.7
20	KGHWT 20 PP	0.18	20	81	30	58.7
25	KGHWT 25 PP	0.28	25	90.5	40	66

1) The basic load ratings are only valid for hardened (670 to 840 HV) and ground shaft raceways.



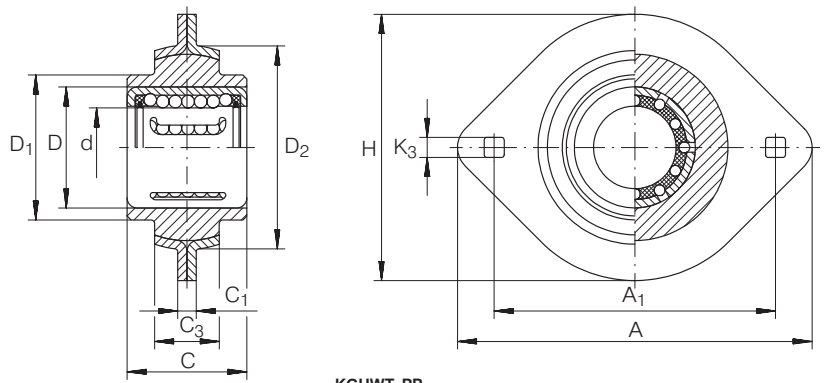

KGHWT..PP

MOUNTING DIMENSIONS							BASIC LOAD RATINGS ¹⁾		SHAFT DIAMETER
A ₁ ± 0.15	C ₁ ± 0.5	C ₃ +1	D	D ₁	D ₂	K ₃	dyn. C N	stat. C ₀ N	
63.5	4	14	24	30	44	7	890	620	16
63.5	4	14	28	32	44	7	1,110	790	20
71.5	4.4	16	35	40	51	8.7	2,280	1,670	25

Linear Ball Bearings

KN, KNO SERIES

- Light Range
- With Relubrication Facility

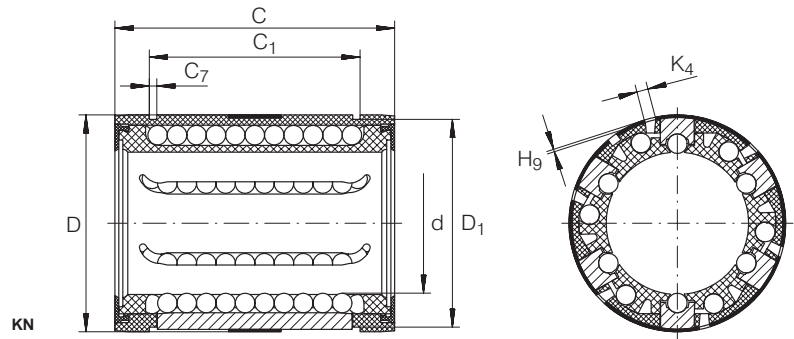

For details on part numbers, descriptive suffixes and various technical references, please refer to front of this section.

For engineering or technical information contact your local sales representative or call Distributor Sales (800)523-6572 or Linear Sales (800)462-3399.

DIMENSION TABLE - Dimensions in mm

SHAFT DIAMETER	PART NUMBER		MASS	DIMENSIONS			MOUNTING DIMENSIONS			
				d	D	C	A ₆ ²⁾	C ₁ H13	C ₇	D ₁
			kg							
12	KN 1232		0.02	12	22	32	—	22.6	1.3	21
16	KN 1636	KNO 1232	0.02	12	22	32	6.5	—	—	—
		KNO 1636	0.03	16	26	36	—	24.6	1.3	25
20	KN 2045	KNO 1636	0.02	16	26	36	9	—	—	—
		KNO 2045	0.06	20	32	45	—	31.2	1.6	30.7
25	KN 2558	KNO 2045	0.05	20	32	45	9	—	—	—
		KNO 2558	0.13	25	40	58	—	43.7	1.85	38
30	KN 3068	KNO 2558	0.11	25	40	58	11.5	—	—	—
		KNO 3068	0.19	30	47	68	—	51.7	1.85	44.7
40	KN 4080	KNO 3068	0.16	30	47	68	14	—	—	—
		KNO 4080	0.35	40	62	80	—	60.3	2.15	59.4
50	KN 50100	KNO 4080	0.3	40	62	80	19	—	—	—
		KNO 50100	0.56	50	75	100	—	77.3	2.65	71.4
		KNO 50100	0.47	50	75	100	22.5	—	—	—

- 1) Linear ball bearings sealed on both sides: suffix "PP".
- 2) Dimension A₆ on diameter d.
- 3) Hole position centered on bearing width C.
- 4) The basic load ratings are only valid for hardened (670 to 840 HV) and ground shaft raceways.
- 5) Basic load rating in main load direction.

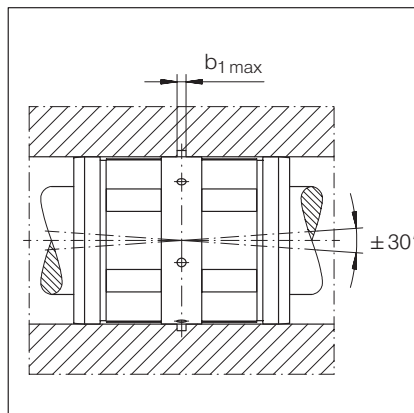

Misalignment compensation ±30'

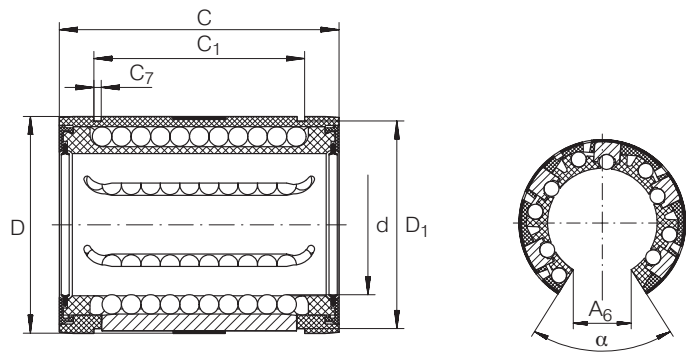

KN..PP

KNO, KNO..PP

										ACCESSORIES	
				MOUNTING DIMENSION	BALL ROWS	BASIC LOAD RATINGS ⁴⁾				SUITABLE CIRCLIPS TO DIN 471	SHAFT DIAMETER
H ₉	H ₁₀	K ₄ ³⁾	α Grad	b ₁ max.	NUMBER	dyn. C _{min} N	stat. C _{0 min} N	dyn. C _{max} N	stat. C _{0 max} N		
0.7	–	3	–	1.5	5	730	510	870	740	22 × 1.2	12
0.7	–	3	66	1.5	4	–	–	840 ⁵⁾	640 ⁵⁾	–	–
0.7	–	3	–	1.5	5	870	620	1,040	910	26 × 1.2	16
0.7	–	3	68	1.5	4	–	–	1,000 ⁵⁾	750 ⁵⁾	–	–
0.9	–	3	–	2.5	6	1,730	1,230	1,830	1,570	32 × 1.5	20
0.9	–	3	55	2.5	5	–	–	1,740 ⁵⁾	1,240 ⁵⁾	–	–
1.4	–	3	–	2.5	6	3,100	2,220	3,250	2,850	42 × 1.75	25
1.4	1.5	3	57	2.5	5	–	–	3,100 ⁵⁾	2,260 ⁵⁾	–	–
2.2	–	3	–	2.5	6	3,750	2,850	3,950	3,650	48 × 1.75	30
2.2	2	3	57	2.5	5	–	–	3,750 ⁵⁾	2,850 ⁵⁾	–	–
2.2	–	3	–	3	6	6,900	4,900	7,300	6,300	63 × 2	40
2.2	1.5	3	56	3	5	–	–	6,900 ⁵⁾	4,900 ⁵⁾	–	–
2.3	–	5	–	3	6	10,000	7,200	10,600	9,200	75 × 2.5	50
2.3	2.5	5	54	3	5	–	–	10,000 ⁵⁾	7,200 ⁵⁾	–	–

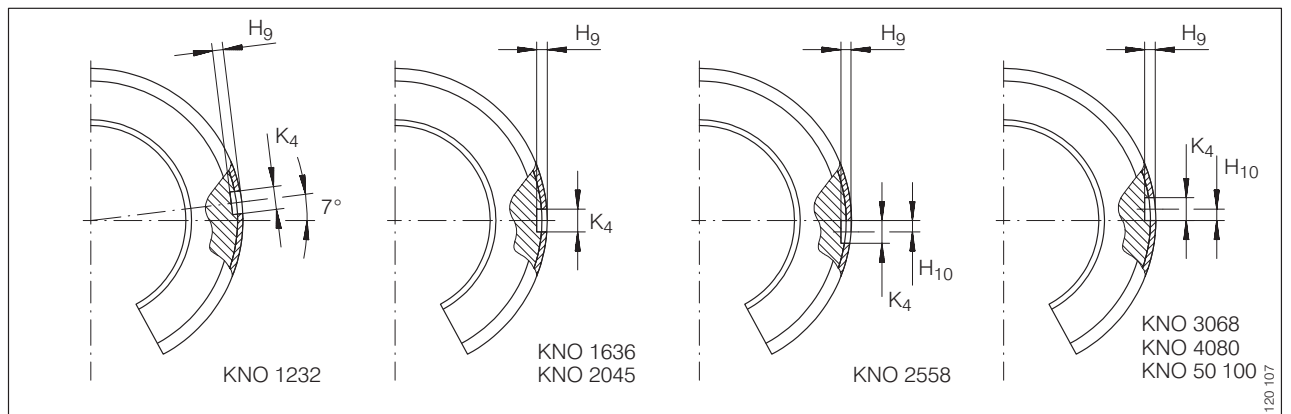

Fixing holes



Linear Ball Bearing And Housing Units

KGN..B PP AS, KGNS..B PP AS SERIES

- Light range
- Sealed, Greased, With Relubrication Facility

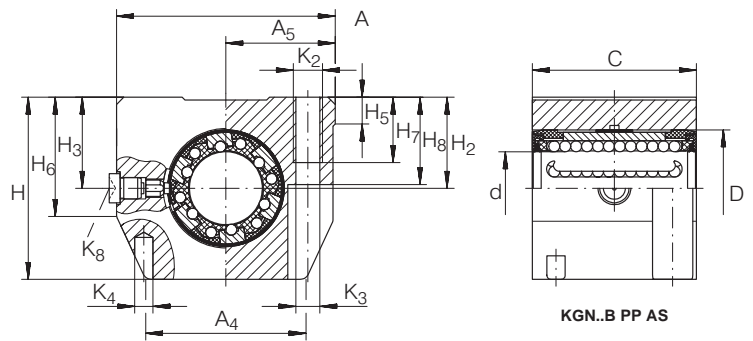

For details on part numbers, descriptive suffixes and various technical references, please refer to front of this section.

For engineering or technical information contact your local sales representative or call Distributor Sales (800)523-6572 or Linear Sales (800)462-3399.

DIMENSION TABLE - Dimensions in mm

SHAFT DIAMETER	PART NUMBER	MASS kg	Dimensions				MOUNTING DIMENSIONS				
			d	A	C	H	A ₁	A ₄	A ₅ ±0.01	C ₂ ¹⁾	D
12	KGN 12 B PP AS	0.1	12	43	32	35	32±0.15	34	21.5	23±0.15	22
	KGNS 12 B PP AS	0.1	12	43	32	35	32±0.15	34	21.5	23±0.15	22
16	KGN 16 B PP AS	0.17	16	53	37	42	40±0.15	40	26.5	26±0.15	26
	KGNS 16 B PP AS	0.17	16	53	37	42	40±0.15	40	26.5	26±0.15	26
20	KGN 20 B PP AS	0.27	20	60	45	50	45±0.15	44	30	32±0.15	32
	KGNS 20 B PP AS	0.27	20	60	45	50	45±0.15	44	30	32±0.15	32
25	KGN 25 B PP AS	0.56	25	78	58	60	60±0.15	59.5	39	40±0.15	40
	KGNS 25 B PP AS	0.56	25	78	58	60	60±0.15	59.5	39	40±0.15	40
30	KGN 30 B PP AS	0.83	30	87	68	70	68±0.15	63	43.5	45±0.15	47
	KGNS 30 B PP AS	0.83	30	87	68	70	68±0.15	63	43.5	45±0.15	47
40	KGN 40 B PP AS	1.55	40	108	80	90	86±0.15	76	54	58±0.15	62
	KGNS 40 B PP AS	1.55	40	108	80	90	86±0.15	76	54	58±0.15	62
50	KGN 50 B PP AS	2.7	50	132	100	105	108±0.2	90	66	50±0.2	75
	KGNS 50 B PP AS	2.7	50	132	100	105	108±0.2	90	66	50±0.2	75

- 1) Dimension C₂ and lubrication hole centered on bearing width C.
- 2) For fixing screws to DIN 912-8.8 and spring washer to DIN 7980.
- 3) Centring for dowel hole.
- 4) Lubrication nipple.
- 5) The basic load ratings are only valid for hardened (670 to 840 HV) and ground shaft raceways.



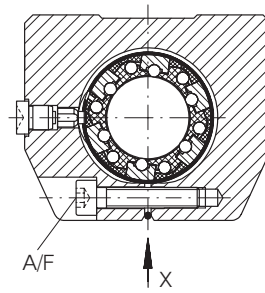

KGNS..B PP AS

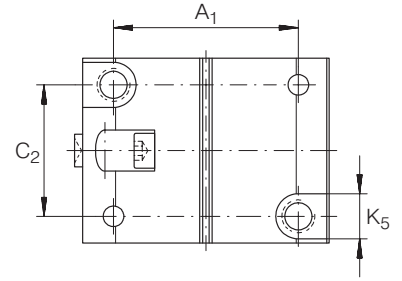

View X

H ₂ +0.008 -0.016	H ₃	H ₅	H ₆	H ₇	H ₈	K ₂	K ₃ ²⁾	K ₄ ³⁾	K ₅ ²⁾	K ₈ ¹⁾⁴⁾	A/F	BALL ROWS	BASIC LOAD RATINGS ⁵⁾		SHAFT DIAMETER
												NUMBER	dyn. C N	stat. C ₀ N	
18	18	6	25.5	11	16.5	M5	4.3	4	8	NIP A1	-	5	780	560	12
18	18	6	25.5	11	16.5	M5	4.3	4	8	NIP A1	2.5	5	780	560	12
22	22	7	28	13	21	M6	5.3	4	10	NIP A1	-	5	1,000	750	16
22	22	7	28	13	21	M6	5.3	4	10	NIP A1	3	5	1,000	750	16
25	25	7.5	33	18	24	M8	6.6	5	11	NIP A1	-	6	1,740	1,240	20
25	25	7.5	33	18	24	M8	6.6	5	11	NIP A1	4	6	1,740	1,240	20
30	30	8.5	40	22	29	M10	8.4	6	15	NIP A2	-	6	3,100	2,230	25
30	30	8.5	40	22	29	M10	8.4	6	15	NIP A2	5	6	3,100	2,230	25
35	35	9.5	44.5	22	34	M10	8.4	6	15	NIP A2	-	6	3,800	2,900	30
35	35	9.5	44.5	22	34	M10	8.4	6	15	NIP A2	5	6	3,800	2,900	30
45	45	11	56	26	44	M12	10.5	8	18	NIP A2	-	6	6,900	4,950	40
45	45	11	56	26	44	M12	10.5	8	18	NIP A2	6	6	6,900	4,950	40
50	50	11	60	35	49	M16	13.5	10	20	NIP A2	-	6	10,100	7,300	50
50	50	11	60	35	49	M16	13.5	10	20	NIP A2	8	6	10,100	7,300	50

Linear Ball Bearing And Housing Units KGNO..PP AS, KGNOS..PP AS SERIES

- Light Range
- Sealed, Greased, With Relubrication Facility

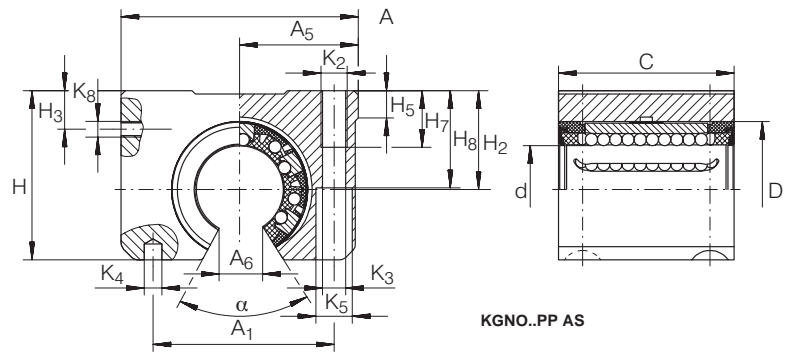

For details on part numbers, descriptive suffixes and various technical references, please refer to front of this section.

For engineering or technical information contact your local sales representative or call Distributor Sales (800)523-6572 or Linear Sales (800)462-3399.

DIMENSION TABLE - Dimensions in mm

SHAFT DIAMETER	PART NUMBER	MASS kg	DIMENSIONS				MOUNTING DIMENSIONS					
			d	A	C	H	A ₁	A ₅ ±0.01	A ₆ ¹⁾	C ₂ ²⁾	D	H ₂ +0.008 -0.016
12	KGNO 12 PP AS	0.09	12	43	32	28	32 ^{±0.15}	21.5	6.5	23 ^{±0.15}	22	18
	KGNOS 12 PP AS	0.09	12	43	32	28	32 ^{±0.15}	21.5	6.5	23 ^{±0.15}	22	18
16	KGNO 16 PP AS	0.15	16	53	37	35	40 ^{±0.15}	26.5	9	26 ^{±0.15}	26	22
	KGNOS 16 PP AS	0.15	16	53	37	35	40 ^{±0.15}	26.5	9	26 ^{±0.15}	26	22
20	KGNO 20 PP AS	0.25	20	60	45	42	45 ^{±0.15}	30	9	32 ^{±0.15}	32	25
	KGNOS 20 PP AS	0.25	20	60	45	42	45 ^{±0.15}	30	9	32 ^{±0.15}	32	25
25	KGNO 25 PP AS	0.52	25	78	58	51	60 ^{±0.15}	39	11.5	40 ^{±0.15}	40	30
	KGNOS 25 PP AS	0.52	25	78	58	51	60 ^{±0.15}	39	11.5	40 ^{±0.15}	40	30
30	KGNO 30 PP AS	0.76	30	87	68	60	68 ^{±0.15}	43.5	14	45 ^{±0.15}	47	35
	KGNOS 30 PP AS	0.76	30	87	68	60	68 ^{±0.15}	43.5	14	45 ^{±0.15}	47	35
40	KGNO 40 PP AS	1.4	40	108	80	77	86 ^{±0.15}	54	19	58 ^{±0.15}	62	45
	KGNOS 40 PP AS	1.4	40	108	80	77	86 ^{±0.15}	54	19	58 ^{±0.15}	62	45
50	KGNO 50 PP AS	2.4	50	132	100	88	108 ^{±0.2}	66	22.5	50 ^{±0.2}	75	50
	KGNOS 50 PP AS	2.4	50	132	100	88	108 ^{±0.2}	66	22.5	50 ^{±0.2}	75	50

In the interim, linear ball bearing and housing units KGNO..PP AS and KGNOS..PP AS with profile grooves will still be supplied.

- 1) Dimension A₆ on diameter d.
- 2) Dimension C₂ and lubrication hole centered on bearing width C.
- 3) For fixing screws to DIN 912-8.8 and spring washer to DIN 7980.
- 4) Centring for dowel hole.
- 5) The basic load ratings are only valid for hardened (670 to 840 HV) and ground shaft raceways.



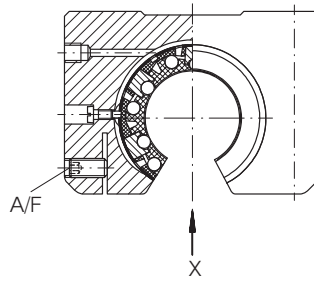

KG NOS..PP AS

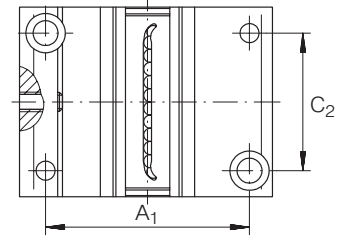

View X

H ₃	H ₅	H ₇	H ₈	K ₂	K ₃ ³⁾	K ₄ ⁴⁾	K ₅ ³⁾	K ₆ ²⁾	A/F	α Grad	BALL ROWS	BASIC LOAD RATINGS ⁵⁾		SHAFT DIAMETER
											NUMBER	dyn. C N	stat. C ₀ N	
8	6	11	16.5	M5	4.3	4	8	M6	–	66	4	840	640	12
8	6	11	16.5	M5	4.3	4	8	M6	2.5	66	4	840	640	
10	7.5	13	21	M6	5.3	4	10	M6	–	68	4	1,000	750	16
10	7.5	13	21	M6	5.3	4	10	M6	2.5	68	4	1,000	750	
11	8	18	24	M8	6.6	5	11	M6	–	55	5	1,740	1,240	20
11	8	18	24	M8	6.6	5	11	M6	2.5	55	5	1,740	1,240	
12.5	9	22	29	M10	8.4	6	15	M8 × 1	–	57	5	3,100	2,260	25
12.5	9	22	29	M10	8.4	6	15	M8 × 1	3	57	5	3,100	2,260	
14	9.5	22	34	M10	8.4	6	15	M8 × 1	–	57	5	3,750	2,850	30
14	9.5	22	34	M10	8.4	6	15	M8 × 1	3	57	5	3,750	2,850	
17.5	12	26	44	M12	10.5	8	18	M8 × 1	–	56	5	6,900	4,900	40
17.5	12	26	44	M12	10.5	8	18	M8 × 1	4	56	5	6,900	4,900	
17.5	12	35	49	M16	13.5	10	20	M8 × 1	–	54	5	10,000	7,200	50
17.5	12	35	49	M16	13.5	10	20	M8 × 1	5	54	5	10,000	7,200	

Linear Ball Bearing And Housing Units KGNC..PP AS, KGNC S..PP AS SERIES

- Light Range
- Sealed, Greased, With Relubrication Facility

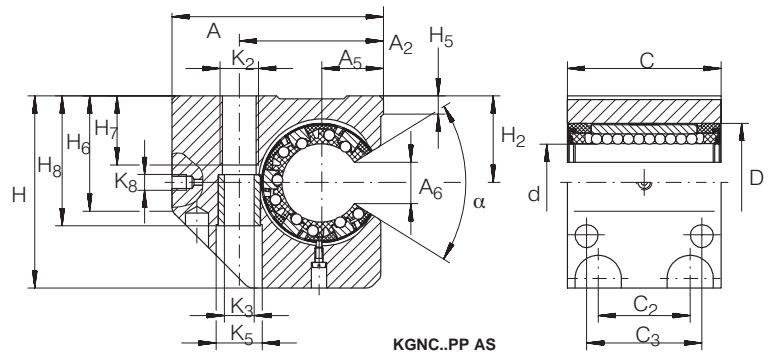

For details on part numbers, descriptive suffixes and various technical references, please refer to front of this section.

For engineering or technical information contact your local sales representative or call Distributor Sales (800)523-6572 or Linear Sales (800)462-3399.

DIMENSION TABLE - Dimensions in mm

SHAFT DIAMETER	PART NUMBER	MASS kg	DIMENSIONS				MOUNTING DIMENSIONS						
			d	A	C	H	A ₂ ±0.15	A ₃	A ₅ ±0.01	A ₆ ¹⁾	C ₂ ²⁾ ±0.15	C ₃ ²⁾	D
20	KGNC 20 PP AS	0.35	20	60	47	60	39	51	17	9	30	36	32
	KGNC S 20 PP AS	0.35	20	60	47	60	39	51	17	9	30	36	32
25	KGNC 25 PP AS	0.68	25	75	58	72	49	64	21	11.5	36	45	40
	KGNC S 25 PP AS	0.68	25	75	58	72	49	64	21	11.5	36	45	40
30	KGNC 30 PP AS	1	30	86	68	82	59	76	25	14	42	52	47
	KGNC S 30 PP AS	1	30	86	68	82	59	76	25	14	42	52	47
40	KGNC 40 PP AS	1.8	40	110	80	100	75	97	32	19	48	60	62
	KGNC S 40 PP AS	1.8	40	110	80	100	75	97	32	19	48	60	62
50	KGNC 50 PP AS	2.9	50	127	100	115	88	109	38	22.5	62	80	75
	KGNC S 50 PP AS	2.9	50	127	100	115	88	109	38	22.5	62	80	75

In the interim, linear ball bearing and housing units KGNC..PP AS and KGNC S..PP AS with profile grooves will still be supplied.

- 1) Dimension A₆ on diameter d.
- 2) Dimension C₂, C₃ and lubrication hole centered on bearing width C.
- 3) Centring for dowel hole.
- 4) For fixing screws to DIN 912-8.8 and spring washer to DIN 7980.
- 5) The basic load ratings are only valid for hardened (670 to 840 HV) and ground shaft raceways.

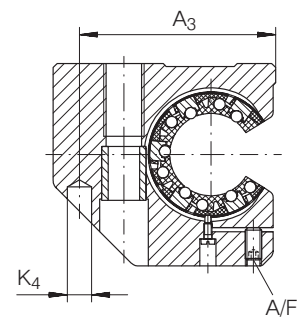

KGNC5..PP AS

H ₂ +0.008 -0.016	H ₅	H ₆	H ₇	H ₈	K ₂	K ₃ ³⁾	K ₄ ⁴⁾	K ₅ ³⁾	K ₆ ²⁾	A/F	α Grad	BALL ROWS	BASIC LOAD RATINGS ⁵⁾		SHAFT DIAMETER
												NUMBER	dyn. C N	stat. C ₀ N	
30	8	37.5	18	42.5	M10	8.4	6	15	M6	–	55	5	1,740	1,240	20
30	8	37.5	18	42.5	M10	8.4	6	15	M6	2.5	55	5	1,740	1,240	
35	8	45	22	50.5	M12	10.5	8	18	M8 × 1	–	57	5	3,100	2,269	25
35	8	45	22	50.5	M12	10.5	8	18	M8 × 1	3	57	5	3,100	2,260	
40	9	52	29	55.5	M16	13.5	10	20	M8 × 1	–	57	5	3,750	2,850	30
40	9	52	29	55.5	M16	13.5	10	20	M8 × 1	3	57	5	3,750	2,850	
45	9	60	36	67.5	M20	15.5	12	24	M8 × 1	–	56	5	6,900	4,900	40
45	9	60	36	67.5	M20	15.5	12	24	M8 × 1	4	56	5	6,900	4,900	
50	9	70	36	79	M20	17.5	12	26	M8 × 1	–	54	5	10,000	7,200	50
50	9	70	36	79	M20	17.5	12	26	M8 × 1	5	54	5	10,000	7,200	

Linear Ball Bearing And Housing Units

KTN..B PP AS, KTNS..B PP AS SERIES

- Light Range
- Sealed, Greased, With Relubrication Facility

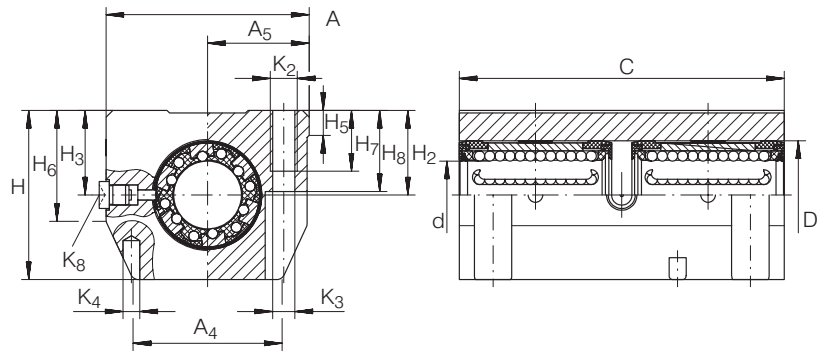

For details on part numbers, descriptive suffixes and various technical references, please refer to front of this section.

For engineering or technical information contact your local sales representative or call Distributor Sales (800)523-6572 or Linear Sales (800)462-3399.

DIMENSION TABLE - Dimensions in mm

SHAFT DIAMETER	PART NUMBER	MASS kg	DIMENSIONS				MOUNTING DIMENSIONS					
			d	A	C	H	A ₁	A ₄	A ₅ ±0.01	C ₂ ¹⁾	C ₃ ¹⁾	D
12	KTN 12 B PP AS	0.21	12	43	70	35	32 ^{±0.15}	34	21.5	56 ^{±0.15}	24	22
	KTNS 12 B PP AS	0.21	12	43	70	35	32 ^{±0.15}	34	21.5	56 ^{±0.15}	24	22
16	KTN 16 B PP AS	0.35	16	53	78	42	40 ^{±0.15}	40	26.5	64 ^{±0.15}	26	26
	KTNS 16 B PP AS	0.35	16	53	78	42	40 ^{±0.15}	40	26.5	64 ^{±0.15}	26	26
20	KTN 20 B PP AS	0.56	20	60	96	50	45 ^{±0.15}	44	30	76 ^{±0.15}	33	32
	KTNS 20 B PP AS	0.56	20	60	96	50	45 ^{±0.15}	44	30	76 ^{±0.15}	33	32
25	KTN 25 B PP AS	1.15	25	78	122	60	60 ^{±0.15}	59.5	39	94 ^{±0.2}	44	40
	KTNS 25 B PP AS	1.15	25	78	122	60	60 ^{±0.15}	59.5	39	94 ^{±0.2}	44	40
30	KTN 30 B PP AS	1.7	30	87	142	70	68 ^{±0.15}	63	43.5	106 ^{±0.2}	54	47
	KTNS 30 B PP AS	1.7	30	87	142	70	68 ^{±0.15}	63	43.5	106 ^{±0.2}	54	47

In the interim, linear ball bearing and housing units KTN..B PP AS and KTNS..B PP AS with profile grooves will still be supplied.

- 1) Dimension C₂, C₃ and lubrication hole centered on bearing width C.
- 2) For fixing screws to DIN 912-8.8 and spring washer to DIN 7980.
- 3) Centring for dowel hole.
- 4) Lubrication nipple.
- 5) The basic load ratings are only valid for hardened (670 to 840 HV) and ground shaft raceways.

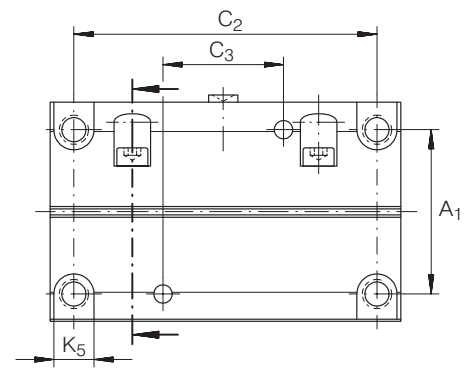
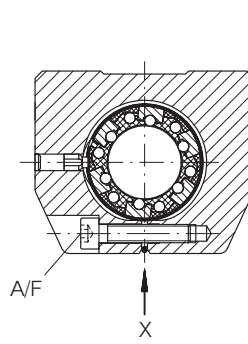

KTNS..B PP AS

View X (rotated through 90°)

H ₂ +0.008 -0.016	H ₃	H ₅	H ₆	H ₇	H ₈	K ₂	K ₃ ²⁾	K ₄ ³⁾	K ₅ ²⁾	K ₈ ⁴⁾	A/F	BALL ROWS	BASIC LOAD RATINGS ⁵⁾		SHAFT DIAMETER
												NUMBER	dyn. C N	stat. C ₀ N	
18	18	6	25.6	11	16.5	M5	4.3	4	8	NIP A1	—	5	1,270	1,110	12
18	18	6	25.6	11	16.5	M5	4.3	4	8	NIP A1	2.5	5	1,270	1,110	
22	22	7	28	13	21	M6	5.3	4	10	NIP A1	—	5	1,620	1,500	16
22	22	7	28	13	21	M6	5.3	4	10	NIP A1	3	5	1,620	1,500	
25	25	7.5	33	18	24	M8	6.6	5	11	NIP A1	—	6	2,850	2,480	20
25	25	7.5	33	18	24	M8	6.6	5	11	NIP A1	4	6	2,850	2,480	
30	30	8.5	40	22	29	M10	8.4	6	15	NIP A2	—	6	5,000	4,450	25
30	30	8.5	40	22	29	M10	8.4	6	15	NIP A2	5	6	5,000	4,450	
35	35	9.5	44.5	22	34	M10	8.4	6	15	NIP A2	—	6	6,100	5,800	30
35	35	9.5	44.5	22	34	M10	8.4	6	15	NIP A2	5	6	6,100	5,800	

Linear Ball Bearing And Housing Units

KTNO..PP AS, KTNOS..PP AS SERIES

- Light Range
- Sealed, Greased, With Relubrication Facility

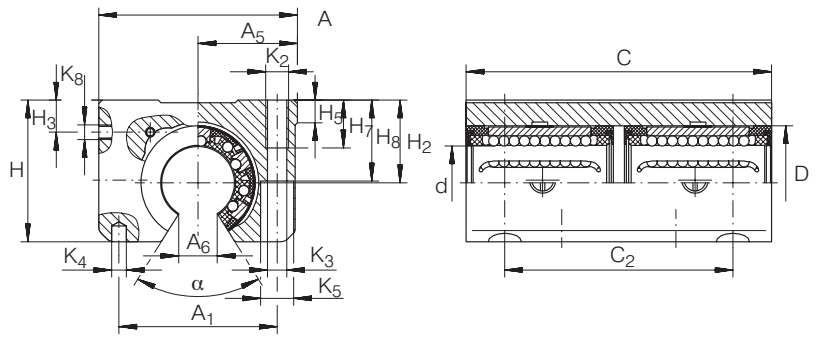

For details on part numbers, descriptive suffixes and various technical references, please refer to front of this section.

For engineering or technical information contact your local sales representative or call Distributor Sales (800)523-6572 or Linear Sales (800)462-3399.

DIMENSION TABLE - Dimensions in mm

SHAFT DIAMETER	PART NUMBER	MASS kg	DIMENSIONS				MOUNTING DIMENSIONS						
			d	A	C	H	A ₁	A ₅ ± 0.01	A ₆ ¹⁾	C ₂ ²⁾	C ₃ ²⁾	D	H ₂ +0.008 -0.016
12	KTNO 12 PP AS	0.19	12	43	70	28	32 ^{±0.15}	21.5	6.5	56 ^{±0.15}	24	22	18
	KTNOS 12 PP AS	0.19	12	43	70	28	32 ^{±0.15}	21.5	6.5	56 ^{±0.15}	24	22	18
16	KTNO 16 PP AS	0.31	16	53	78	35	40 ^{±0.15}	26.5	9	64 ^{±0.15}	26	26	22
	KTNOS 16 PP AS	0.31	16	53	78	35	40 ^{±0.15}	26.5	9	64 ^{±0.15}	26	26	22
20	KTNO 20 PP AS	0.52	20	60	96	42	45 ^{±0.15}	30	9	76 ^{±0.15}	33	32	25
	KTNOS 20 PP AS	0.52	20	60	96	42	45 ^{±0.15}	30	9	76 ^{±0.15}	33	32	25
25	KTNO 25 PP AS	1.06	25	78	122	51	60 ^{±0.15}	39	11.5	94 ^{±0.2}	44	40	30
	KTNOS 25 PP AS	1.06	25	78	122	51	60 ^{±0.15}	39	11.5	94 ^{±0.2}	44	40	30
30	KTNO 30 PP AS	1.55	30	87	142	60	68 ^{±0.15}	43.5	14	106 ^{±0.2}	54	47	35
	KTNOS 30 PP AS	1.55	30	87	142	60	68 ^{±0.15}	43.5	14	106 ^{±0.2}	54	47	35

In the interim, linear ball bearing and housing units KTNO..PP AS and KTNOS..PP AS with profile grooves will still be supplied.

- 1) Dimension A₆ on diameter d.
- 2) Dimension C₂, C₃ and lubrication hole centered on bearing width C.
- 3) For fixing screws to DIN 912-8.8 and spring washer to DIN 7980.
- 4) Centring for dowel hole.
- 5) The basic load ratings are only valid for hardened (670 to 840 HV) and ground shaft raceways.

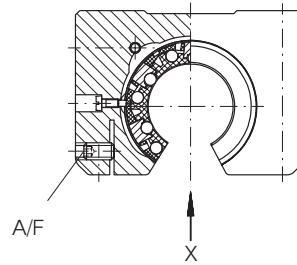

KTNOS..PP AS

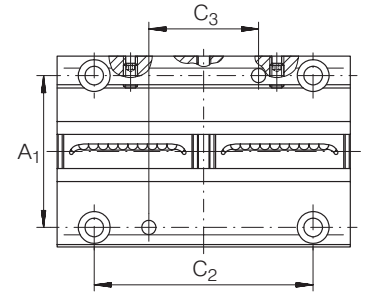

View X (rotated through 90°)

											BALL ROWS	BASIC LOAD RATINGS ⁵⁾		SHAFT DIAMETER
H ₃	H ₅	H ₇	H ₈	K ₂	K ₃ ³⁾	K ₄ ⁴⁾	K ₅ ³⁾	K ₆ ²⁾	A/F	α Grad	NUMBER	dyn. C N	stat. C ₀ N	
8	6	11	16.5	M5	4.3	4	8	M6	–	66	4	1,370	1,270	12
8	6	11	16.5	M5	4.3	4	8	M6	2.5	66	4	1,370	1,270	
10	7.5	13	21	M6	5.3	4	10	M6	–	68	4	1,620	1,500	16
10	7.5	13	21	M6	5.3	4	10	M6	2.5	68	4	1,620	1,500	
11	8	18	24	M8	6.6	5	11	M6	–	55	5	2,850	2,480	20
11	8	18	24	M8	6.6	5	11	M6	2.5	55	5	2,850	2,480	
12.5	9	22	29	M10	8.4	6	15	M8×1	–	57	5	5,100	4,550	25
12.5	9	22	29	M10	8.4	6	15	M8×1	3	57	5	5,100	4,550	
14	9.5	22	34	M10	8.4	6	15	M8×1	–	57	5	6,100	5,700	30
14	9.5	22	34	M10	8.4	6	15	M8×1	3	57	5	6,100	5,700	

Linear Ball Bearing And Housing Units KTFN..PP AS SERIES

- Light Range
- Sealed, Greased, With Relubrication Facility

For details on part numbers, descriptive suffixes and various technical references, please refer to front of this section.

For engineering or technical information contact your local sales representative or call Distributor Sales (800)523-6572 or Linear Sales (800)462-3399.

DIMENSION TABLE · Dimensions in mm										
SHAFT DIAMETER	PART NUMBER	MASS kg	DIMENSIONS				MOUNTING DIMENSIONS			
			d	A	C	H	A ₁ ± 0.15	C ₁	C ₃	C ₇
12	KTFN 12 PP AS	0.2	12	42	70	34	32	46	10	35
16	KTFN 16 PP AS	0.3	16	50	78	40	38	50	10	39
20	KTFN 20 PP AS	0.5	20	60	96	50	45	60	10	48
25	KTFN 25 PP AS	1	25	74	122	60	56	73	10	61
30	KTFN 30 PP AS	1.4	30	84	142	70	64	82	10	71

1) Recommended tolerance for housing bore: D₁ H7.

2) The basic load ratings are only valid for hardened (670 to 840 HV) and ground shaft raceways.



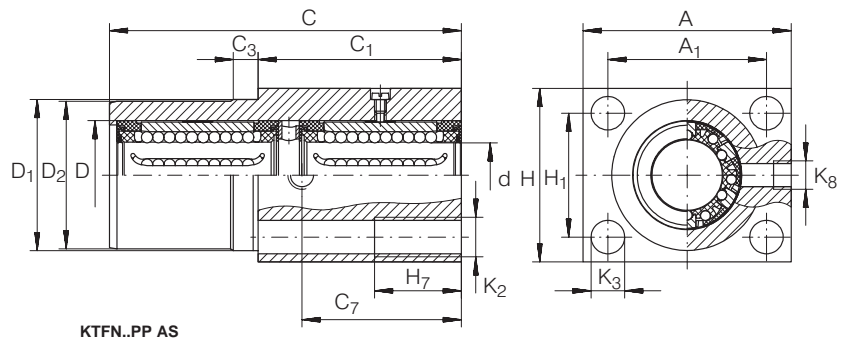

D	D ₁ ¹⁾ g7	D ₂ -0.1 -0.3	H ₁ ±0.15	H ₇	K ₂	K ₃	K ₈	BALL ROWS	BASIC LOAD RATINGS ²⁾		SHAFT DIAMETER
								NUMBER	dyn. C N	stat. C ₀ N	
22	30	30	24	13	M6	5.3	M8 × 1	5	1,270	1,110	12
26	35	35	28	18	M8	6.6	M8 × 1	5	1,620	1,500	16
32	42	42	35	22	M10	8.4	M8 × 1	6	2,850	2,480	20
40	52	52	42	26	M12	10.5	M8 × 1	6	5,000	4,450	25
47	61	61	50	35	M16	13.5	M8 × 1	6	6,100	5,800	30

Linear Ball Bearings

KB, KBS, KBO SERIES

- Heavy Range

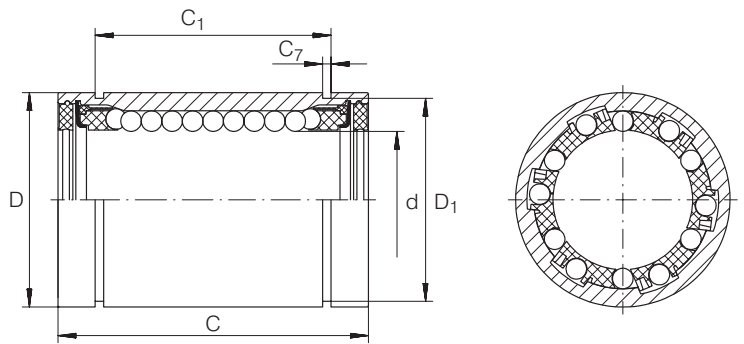

For details on part numbers, descriptive suffixes and various technical references, please refer to front of this section.

For engineering or technical information contact your local sales representative or call Distributor Sales (800)523-6572 or Linear Sales (800)462-3399.

DIMENSION TABLE - Dimensions in mm

SHAFT DIAMETER	PART NUMBER			MASS kg	DIMENSIONS			MOUNTING DIMENSIONS	
					d Deviations ²⁾	D ²⁾ h5	C h12	A ₆ ³⁾	C ₁ H13
12	KB 1232	–	–	0.04	12 ^{+0.008}	22	32	–	22.6
	–	KBS 1232	–	0.04		22	32	–	22.6
	–	–	KBO 1232	0.03		22	32	7.7	22.6
16	KB 1636	–	–	0.05	16 ^{+0.009} –0.001	26	36	–	24.6
	–	KBS 1636	–	0.05		26	36	–	24.6
	–	–	KBO 1636	0.04		26	36	10.1	24.6
20	KB 2045	–	–	0.09	20 ^{+0.009} –0.001	32	45	–	31.2
	–	KBS 2045	–	0.09		32	45	–	31.2
	–	–	KBO 2045	0.07		32	45	10	31.2
25	KB 2558	–	–	0.19	25 ^{+0.011} –0.001	40	58	–	43.7
	–	KBS 2558	–	0.19		40	58	–	43.7
	–	–	KBO 2558	0.15		40	58	12.5	43.7
30	KB 3068	–	–	0.3	30 ^{+0.011} –0.001	47	68	–	51.7
	–	KBS 3068	–	0.3		47	68	–	51.7
	–	–	KBO 3068	0.24		47	68	13.6	51.7
40	KB 4080	–	–	0.6	40 ^{+0.013} –0.002	62	80	–	60.3
	–	KBS 4080	–	0.6		62	80	–	60.3
	–	–	KBO 4080	0.52		62	80	18.2	60.3
50	KB 50100	–	–	1	50 ^{+0.013} –0.002	75	100	–	77.3
	–	KBS 50100	–	1		75	100	–	77.3
	–	–	KBO 50100	0.85		75	100	22.7	77.3

- 1) Linear ball bearings sealed on both sides: suffix "PP".
Linear ball bearings with relubrication facility: suffix "AS".
- 2) The tolerances are valid for series KB.
- 3) Dimension A₆ on diameter d.
- 4) Groove dimensions suitable for circlips to DIN 471.
- 5) Bore position centered on bearing width C.
- 6) The basic load ratings are only valid for hardened (670 to 840 HV) and ground shaft raceways.
- 7) Basic load rating in main load direction.

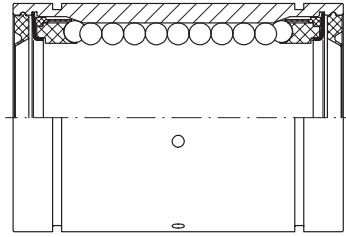

KB..PP AS

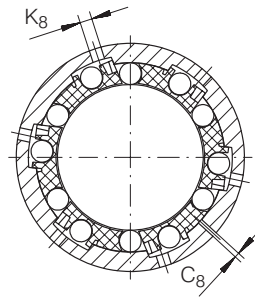

KBS..AS, KBS..PP AS

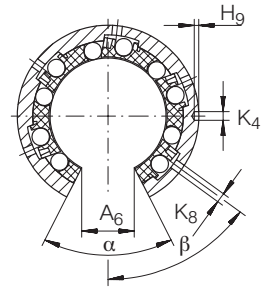

KBO..AS, KBO..PP AS

C ₇ ⁴⁾	C ₈	D ₁ ⁴⁾	H ₉	K ₄ ⁵⁾	K ₈	α Grad	β Grad	BALL ROWS	BASIC LOAD RATINGS ⁶⁾				SHAFT DIAMETER
								NUMBER	dyn. C _{min} N	stat. C _{0 min} N	dyn. C _{max} N	stat. C _{0 max} N	
1.3	–	21	–	–	1.5	–	–	5	540	385	640	570	12
1.3	1	21	–	–	1.5	–	–	5	540	385	640	570	
1.3	–	21	1.2	2.2	1.5	78	64	4	–	–	600 ⁷⁾	445 ⁷⁾	
1.3	–	24.9	–	–	2	–	–	5	710	530	840	780	
1.3	1	24.9	–	–	2	–	–	5	710	530	840	780	
1.3	–	24.9	1.2	2.2	2	78	64	4	–	–	800 ⁷⁾	620 ⁷⁾	
1.6	–	30.3	–	–	2	–	–	6	1,570	1,230	1,660	1,570	20
1.6	1	30.3	–	–	2	–	–	6	1,570	1,230	1,660	1,570	
1.6	–	30.3	1.2	2.2	2	60	52	5	–	–	1,600 ⁷⁾	1,280 ⁷⁾	
1.85	–	37.5	–	–	2.5	–	–	6	2,800	2,220	2,950	2,850	25
1.85	1	37.5	–	–	2.5	–	–	6	2,800	2,220	2,950	2,850	
1.85	–	37.5	1.5	3	2.5	60	53	5	–	–	2,850 ⁷⁾	2,330 ⁷⁾	
1.85	–	44.5	–	–	2.5	–	–	6	3,600	2,850	3,800	3,600	30
1.85	1	44.5	–	–	2.5	–	–	6	3,600	2,850	3,800	3,600	
1.85	–	44.5	1.5	3	2.5	54	55	5	–	–	3,700 ⁷⁾	3,000 ⁷⁾	
2.15	–	59	–	–	3	–	–	6	6,000	4,400	6,400	5,600	
2.15	1	59	–	–	3	–	–	6	6,000	4,400	6,400	5,600	
2.15	–	59	1.5	3	3	54	54	5	–	–	6,100 ⁷⁾	4,600 ⁷⁾	
2.65	–	72	–	–	4	–	–	6	8,700	6,300	9,200	8,000	50
2.65	1	72	–	–	4	–	–	6	8,700	6,300	9,200	8,000	
2.65	–	72	1.5	3	4	54	54	5	–	–	8,900 ⁷⁾	6,600 ⁷⁾	

Linear Ball Bearing And Housing Units

KGB..PP AS, KGBS..PP AS, KGBO..PP AS SERIES

- Heavy Range
- Sealed, Greased, With Relubrication Facility

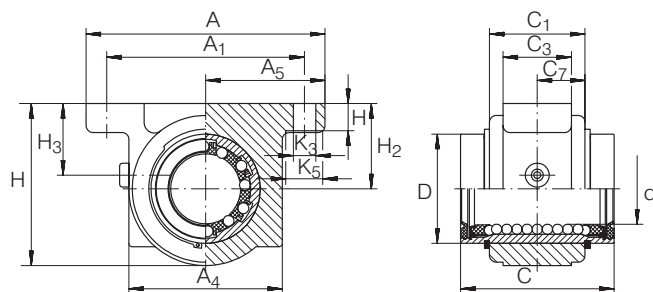

KGB..PP AS

For details on part numbers, descriptive suffixes and various technical references, please refer to front of this section.

For engineering or technical information contact your local sales representative or call Distributor Sales (800)523-6572 or Linear Sales (800)462-3399.

DIMENSION TABLE - Dimensions in mm

SHAFT DIAMETER	PART NUMBER			MASS	DIMENSIONS			MOUNTING DIMENSIONS			
					d Deviations ¹⁾	A	C h12	H	A ₁	A ₄	A ₅
12	KGB 1232 PP AS	–	–	0.1	12 ^{+0.008}	52	32	35.8	42 ^{±0.15}	31.6	26 ^{±0.02}
	–	KGBS 1232 PP AS	–	0.1		52	32	35.8	42 ^{±0.15}	31.6	26 ^{±0.02}
	–	–	KGBO 1232 PP AS	0.09		52	32	–	42 ^{±0.15}	31.6	26 ^{±0.02}
16	KGB 1636 PP AS	–	–	0.14	16 ^{+0.009} –0.001	56	36	37.5	46 ^{±0.15}	35	28 ^{±0.02}
	–	KGBS 1636 PP AS	–	0.14		56	36	37.5	46 ^{±0.15}	35	28 ^{±0.02}
	–	–	KGBO 1636 PP AS	0.12		56	36	–	46 ^{±0.15}	35	28 ^{±0.02}
20	KGB 2045 PP AS	–	–	0.3	20 ^{+0.009} –0.001	70	45	48	58 ^{±0.15}	46	35 ^{±0.02}
	–	KGBS 2045 PP AS	–	0.3		70	45	48	58 ^{±0.15}	46	35 ^{±0.02}
	–	–	KGBO 2045 PP AS	0.25		70	45	–	58 ^{±0.15}	46	35 ^{±0.02}
25	KGB 2558 PP AS	–	–	0.58	25 ^{+0.011} –0.001	80	58	58	68 ^{±0.15}	56	40 ^{±0.02}
	–	KGBS 2558 PP AS	–	0.58		80	58	58	68 ^{±0.15}	56	40 ^{±0.02}
	–	–	KGBO 2558 PP AS	0.49		80	58	–	68 ^{±0.15}	56	40 ^{±0.02}
30	KGB 3068 PP AS	–	–	0.9	30 ^{+0.011} –0.001	88	68	67	76 ^{±0.2}	64	44 ^{±0.02}
	–	KGBS 3068 PP AS	–	0.9		88	68	67	76 ^{±0.2}	64	44 ^{±0.02}
	–	–	KGBO 3068 PP AS	0.78		88	68	–	76 ^{±0.2}	64	44 ^{±0.02}
40	KGB 4080 PP AS	–	–	1.43	40 ^{+0.013} –0.002	108	80	83.5	94 ^{±0.2}	77	54 ^{±0.02}
	–	KGBS 4080 PP AS	–	1.43		108	80	83.5	94 ^{±0.2}	77	54 ^{±0.02}
	–	–	KGBO 4080 PP AS	1.28		108	80	–	94 ^{±0.2}	77	54 ^{±0.02}
50	KGB 50100 PP AS	–	–	2.78	50 ^{+0.013} –0.002	135	100	98	116 ^{±0.2}	96	67.5 ^{±0.05}
	–	KGBS 50100 PP AS	–	2.78		135	100	98	116 ^{±0.2}	96	67.5 ^{±0.05}
	–	–	KGBO 50100 PP AS	2.46		135	100	–	116 ^{±0.2}	96	67.5 ^{±0.05}

1) The tolerances are valid for series KGB..PP AS only.

2) Dimension A₆ on diameter d.

3) For fixing screws to DIN 912-8.8 and spring washer to DIN 7980.

5) The basic load ratings are only valid for hardened (670 to 840 HV) and ground shaft raceways.

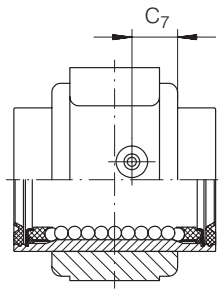

KGBO..PP AS

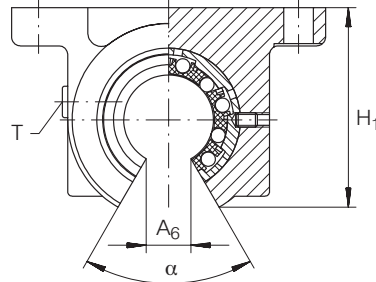

KGBO, KGBO..PP AS

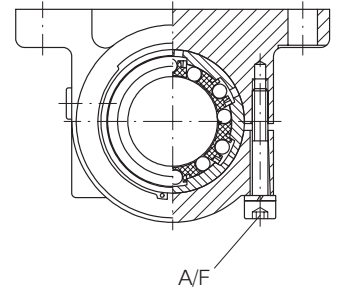

KGBS, KGBS..PP AS

A ₆ ²⁾	C ₁	C ₃	C ₇	D ¹⁾ h5	H ₁	H ₂ ±0.015	H ₃	H ₈	K ₃ ³⁾	K ₅ ³⁾	α Grad	A/F	INA LUBRICATION NIPPLE ⁴⁾ T	BALL ROWS NUMBER	BASIC LOAD RATINGS ⁵⁾		SHAFT DIAMETER
															dyn. C N	stat. C ₀ N	
-	20	12	10	22	-	20	15	6	5.5	10	-	-	NIP A1	5	540	385	12
-	20	12	10	22	-	20	15	6	5.5	10	-	2	NIP A1	5	540	385	12
7.7	20	12	7	22	32	20	15	6	5.5	10	78	-	NIP A1	4	600	445	16
-	22	15	11	26	-	20	15	6	5.5	10	-	-	NIP A1	5	710	530	16
-	22	15	11	26	-	20	15	6	5.5	10	-	2	NIP A1	5	710	530	16
10.1	22	15	7	26	33.5	20	15	6	5.5	10	78	-	NIP A1	4	800	620	16
-	28	20	14	32	-	25	21	8	6.6	11	-	-	NIP A1	6	1,570	1,230	20
-	28	20	14	32	-	25	21	8	6.6	11	-	3	NIP A1	6	1,570	1,230	20
10	28	20	10	32	45	25	21	8	6.6	11	60	-	NIP A1	5	1,600	1,280	20
-	40	28	20	40	-	30	23	10	6.6	11	-	-	NIP A1	6	2,800	2,220	25
-	40	28	20	40	-	30	23	10	6.6	11	-	3	NIP A1	6	2,800	2,220	25
12.5	40	28	15	40	54.5	30	23	10	6.6	11	60	-	NIP A1	5	2,850	2,330	25
-	48	32	24	47	-	35	25	10	6.6	11	-	-	NIP A2	6	3,600	2,850	30
-	48	32	24	47	-	35	25	10	6.6	11	-	4	NIP A2	6	3,600	2,850	30
13.6	48	32	19	47	63.5	35	25	10	6.6	11	54	-	NIP A2	5	3,700	3,000	30
-	56	40	28	62	-	45	30	12	9	15	-	-	NIP A2	6	6,000	4,400	40
-	56	40	28	62	-	45	30	12	9	15	-	4	NIP A2	6	6,000	4,400	40
18.2	56	40	23	62	79.5	45	30	12	9	15	54	-	NIP A2	5	6,100	4,600	40
-	72	52	36	75	-	50	34	14	11	18	-	-	NIP A2	6	8,700	6,300	50
-	72	52	36	75	-	50	34	14	11	18	-	5	NIP A2	6	8,700	6,300	50
22.7	72	52	28	75	93	50	34	14	11	18	54	-	NIP A2	5	8,900	6,600	50

Linear Ball Bearing And Housing Units

KGBA..PP AS, KGBAS..PP AS, KGBAO..PP AS SERIES

- Heavy Range
- Sealed, Greased, With Relubrication Facility

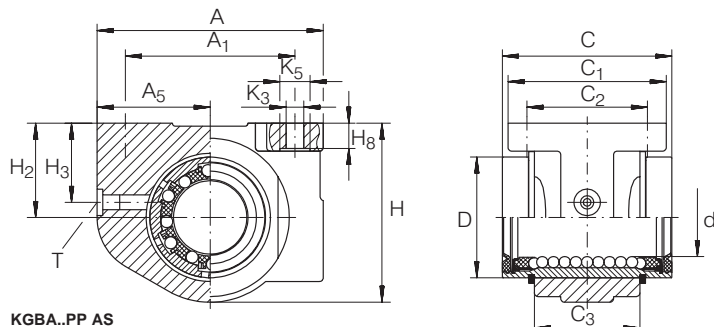

For details on part numbers, descriptive suffixes and various technical references, please refer to front of this section.

For engineering or technical information contact your local sales representative or call Distributor Sales (800)523-6572 or Linear Sales (800)462-3399.

DIMENSION TABLE - Dimensions in mm

SHAFT DIAMETER	PART NUMBER			MASS kg	DIMENSIONS				MOUNTING DIMENSIONS	
					d Deviations ¹⁾	A	C	H	A ₁	A ₅
12	KGBA 1232 PP AS	–	–	0.08	12 ^{+0.008}	42	32	34	32 ^{±0.15}	21 ^{±0.01}
	–	KGBAS 1232 PP AS	–	0.08		42	32	34	32 ^{±0.15}	21 ^{±0.01}
	–	–	KGBAO 1232 PP AS	0.07		42	32	–	32 ^{±0.15}	21 ^{±0.01}
16	KGBA 1636 PP AS	–	–	0.12	16 ^{+0.009} –0.001	50	36	41	40 ^{±0.15}	25 ^{±0.01}
	–	KGBAS 1636 PP AS	–	0.12		50	36	41	40 ^{±0.15}	25 ^{±0.01}
	–	–	KGBAO 1636 PP AS	0.1		50	36	–	40 ^{±0.15}	25 ^{±0.01}
20	KGBA 2045 PP AS	–	–	0.2	20 ^{+0.009} –0.001	60	45	47.5	45 ^{±0.15}	30 ^{±0.01}
	–	KGBAS 2045 PP AS	–	0.2		60	45	47.5	45 ^{±0.15}	30 ^{±0.01}
	–	–	KGBAO 2045 PP AS	0.17		60	45	–	45 ^{±0.15}	30 ^{±0.01}
25	KGBA 2558 PP AS	–	–	0.41	25 ^{+0.011} –0.001	74	58	60	60 ^{±0.2}	37 ^{±0.01}
	–	KGBAS 2558 PP AS	–	0.41		74	58	60	60 ^{±0.2}	37 ^{±0.01}
	–	–	KGBAO 2558 PP AS	0.35		74	58	–	60 ^{±0.2}	37 ^{±0.01}
30	KGBA 3068 PP AS	–	–	0.61	30 ^{+0.011} –0.001	84	68	67	68 ^{±0.2}	42 ^{±0.01}
	–	KGBAS 3068 PP AS	–	0.61		84	68	67	68 ^{±0.2}	42 ^{±0.01}
	–	–	KGBAO 3068 PP AS	0.53		84	68	–	68 ^{±0.2}	42 ^{±0.01}
40	KGBA 4080 PP AS	–	–	1.2	40 ^{+0.013} –0.002	108	80	87	86 ^{±0.2}	54 ^{±0.015}
	–	KGBAS 4080 PP AS	–	1.2		108	80	87	86 ^{±0.2}	54 ^{±0.015}
	–	–	KGBAO 4080 PP AS	1.07		108	80	–	86 ^{±0.2}	54 ^{±0.015}
50	KGBA 50100 PP AS	–	–	1.88	50 ^{+0.013} –0.002	130	100	98	108 ^{±0.2}	65 ^{±0.015}
	–	KGBAS 50100 PP AS	–	1.88		130	100	98	108 ^{±0.2}	65 ^{±0.015}
	–	–	KGBAO 50100 PP AS	1.65		130	100	–	108 ^{±0.2}	65 ^{±0.015}

1) The tolerances are valid for series KGBA..PP AS only.

2) Dimension A₆ on diameter d.

3) For fixing screws to DIN 912-8.8 and spring washer to DIN 7 980.

5) The basic load ratings are only valid for hardened (670 to 840 HV) and ground shaft raceways.

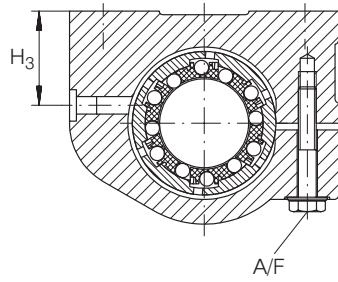

KGBAS.PP AS

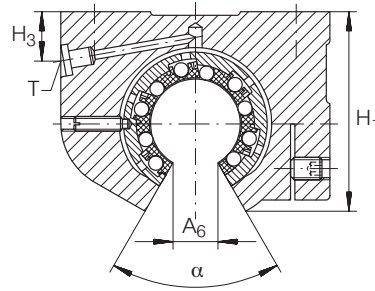

KGBAO..PP AS

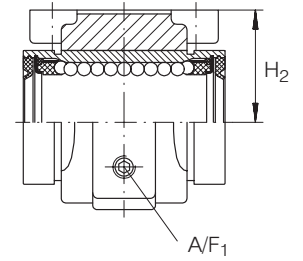

KGBAO..PP AS

A ₆ ²⁾	C ₁	C ₂	C ₃	D ₁ ¹⁾ h5	H ₁	H ₂ ¹⁾	H ₃	H ₈	K ₃ ³⁾	K ₅ ³⁾	α	A/F	A/F ₁	INA LUBRICATION NIPPLE T	BALL ROWS NUMBER	BASIC LOAD RATINGS ⁵⁾		SHAFT DIAMETER
																dyn. C N	stat. C ₀ N	
-	32	23±0.15	20	22	-	18±0.01	15	4.8	4.7	8	-	-	-	NIP A1	5	540	385	12
-	32	23±0.15	20	22	-	18±0.01	15	4.8	4.7	8	-	7	-	NIP A1	5	540	385	12
7.7	32	23±0.15	20	22	30.5	18±0.01	7.8	4.8	4.7	8	78	-	2	NIP A1	4	600	445	16
-	35	26±0.15	22	26	-	22±0.01	15	5.4	4.7	8	-	-	-	NIP A1	5	710	530	16
-	35	26±0.15	22	26	-	22±0.01	15	5.4	4.7	8	-	7	-	NIP A1	5	710	530	16
10.1	35	26±0.15	22	26	37	22±0.01	10	5.4	4.7	8	78	-	2.5	NIP A1	4	800	620	16
-	42	32±0.15	28	32	-	25±0.01	21	6.7	4.7	8	-	-	-	NIP A1	6	1,570	1,230	20
-	42	32±0.15	28	32	-	25±0.01	21	6.7	4.7	8	-	7	-	NIP A1	6	1,570	1,230	20
10	42	32±0.15	28	32	44.5	25±0.01	11	6.7	4.7	8	60	-	2.5	NIP A1	5	1,600	1,280	20
-	54	40±0.2	40	40	-	30±0.01	23	7.8	5.7	10	-	-	-	NIP A1	6	2,800	2,220	25
-	54	40±0.2	40	40	-	30±0.01	23	7.8	5.7	10	-	8	-	NIP A1	6	2,800	2,220	25
12.5	54	40±0.2	40	40	56	30±0.01	13	7.8	5.7	10	60	-	3	NIP A1	5	2,850	2,330	25
-	60	45±0.2	48	47	-	35±0.01	25	8.7	6.8	11	-	-	-	NIP A2	6	3,600	2,850	30
-	60	45±0.2	48	47	-	35±0.01	25	8.7	6.8	11	-	10	-	NIP A2	6	3,600	2,850	30
13.6	60	45±0.2	48	47	63.5	35±0.01	14	8.7	6.8	11	54	-	3	NIP A2	5	3,700	3,000	30
-	78	58±0.2	56	62	-	45±0.01	30	11	9.2	15	-	-	-	NIP A2	6	6,000	4,400	40
-	78	58±0.2	56	62	-	45±0.01	30	11	9.2	15	-	13	-	NIP A2	6	6,000	4,400	40
18.2	78	58±0.2	56	62	82.5	45±0.01	18	11	9.2	15	54	-	4	NIP A2	5	6,100	4,600	40
-	70	50±0.2	72	75	-	50±0.015	34	12.5	9.2	15	-	-	-	NIP A2	6	8,700	6,300	50
-	70	50±0.2	72	75	-	50±0.015	34	12.5	9.2	15	-	13	-	NIP A2	6	8,700	6,300	50
22.7	70	50±0.2	72	75	93	50±0.015	19	12.5	9.2	15	54	-	4	NIP A2	5	8,900	6,600	50

Linear Ball Bearing And Housing Units

KTB..B PP AS, KTBO..PP AS SERIES

- Heavy Range
- Sealed, Greased, With Relubrication Facility

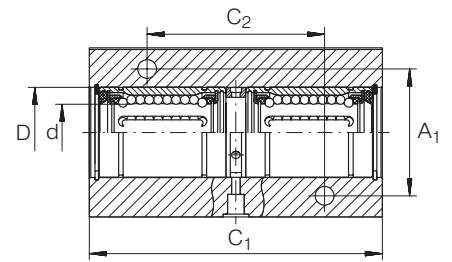
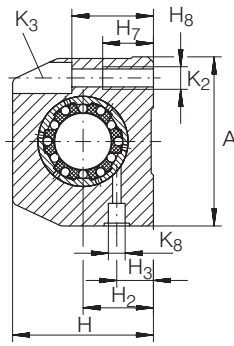

KTB..B PP AS

For details on part numbers, descriptive suffixes and various technical references, please refer to front of this section.

For engineering or technical information contact your local sales representative or call Distributor Sales (800)523-6572 or Linear Sales (800)462-3399.

DIMENSION TABLE - Dimensions in mm

SHAFT DIAMETER	PART NUMBER		MASS kg	DIMENSIONS			MOUNTING DIMENSIONS				
				d Deviations ¹⁾	A	H	A ₁	A ₆ ²⁾	C ₁	C ₂	D
12	KTB 12 B PP AS	–	0.31	12 ^{+0.008}	43	35	30 ^{±0.15}	–	76	40 ^{±0.15}	22
	–	KTBO 12 PP AS	0.26		42	30	30 ^{±0.15}	7.7	76	40 ^{±0.15}	22
16	KTB 16 B PP AS	–	0.46	16 ^{+0.009} –0.001	53	42	36 ^{±0.15}	–	84	45 ^{±0.15}	26
	–	KTBO 16 PP AS	0.36		50	35	36 ^{±0.15}	10.1	84	45 ^{±0.15}	26
20	KTB 20 B PP AS	–	0.8	20 ^{+0.009} –0.001	60	50	45 ^{±0.15}	–	104	55 ^{±0.15}	32
	–	KTBO 20 PP AS	0.62		60	42	45 ^{±0.15}	10	104	55 ^{±0.15}	32
25	KTB 25 B PP AS	–	1.49	25 ^{+0.011} –0.001	78	60	54 ^{±0.15}	–	130	70 ^{±0.2}	40
	–	KTBO 25 PP AS	1.18		74	51	54 ^{±0.15}	12.5	130	70 ^{±0.2}	40
30	KTB 30 B PP AS	–	2.3	30 ^{+0.011} –0.001	87	70	62 ^{±0.15}	–	152	85 ^{±0.2}	47
	–	KTBO 30 PP AS	1.84		84	60	62 ^{±0.15}	13.6	152	85 ^{±0.2}	47

1) The tolerances are valid for series KTB..B PP AS only.

2) Dimension A₆ on diameter d.

3) The basic load ratings are only valid for hardened (670 to 840 HV) and ground shaft raceways and uniform loading on both the linear ball bearings.

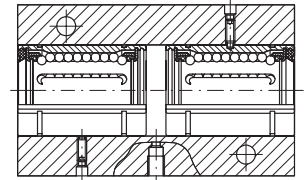
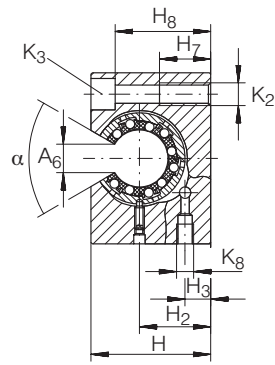

KTBO..PP AS

							K ₃ FOR FIXING SCREWS		BASIC LOAD RATINGS ³⁾		SHAFT DIAMETER
H ₂ ± 0.015	H ₃	H ₇	H ₈	K ₂	K ₈	α Grad	DIN 912	DIN 6 912	dyn. C N	stat. C ₀ N	
18	10	13	28	M6	NIP A1	–	M5	–	880	770	12
18	6	13	24.5	M6	M6	78	–	M5	980	890	16
22	12	13	35	M6	NIP A1	–	M5	–	1,150	1,060	
22	8	13	29.5	M6	M6	78	–	M5	1,290	1,240	
25	13	18	37	M8	NIP A1	–	M6	–	2,550	2,450	
25	9	18	35.5	M8	M6	60	–	M6	2,600	2,550	25
30	15	22	49	M10	NIP A2	–	M8	–	4,550	4,450	
30	9	22	43	M10	M8 × 1	60	–	M8	4,650	4,650	
35	16	26	52	M12	NIP A2	–	M10	–	5,900	5,700	30
35	11	26	50.5	M12	M8 × 1	54	–	M10	6,000	6,000	

Permaglide® Linear Plain Bearings

PAB..PP AS, PABO..PP AS SERIES

- Plain Bearing Range
- Sealed, Greased, With Relubrication Facility

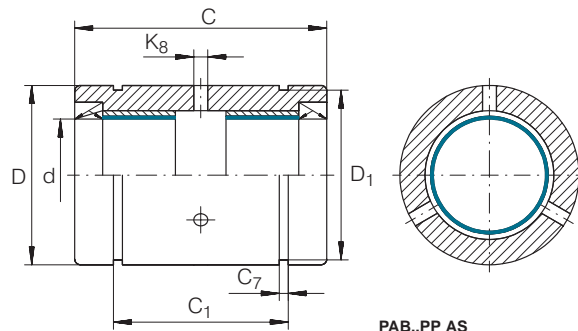

PAB..PP AS

For details on part numbers, descriptive suffixes and various technical references, please refer to front of this section.

For engineering or technical information contact your local sales representative or call Distributor Sales (800)523-6572 or Linear Sales (800)462-3399.

DIMENSION TABLE · Dimensions in mm

SHAFT DIAMETER	PART NUMBER		MASS kg	DIMENSIONS		
				d	D ¹⁾ h7	C h12
12	PAB 1232 PP AS	PABO 1232 PP AS	0.026	12	22	32
		PABO 1232 PP AS	0.021	12	22	32
16	PAB 1636 PP AS	PABO 1636 PP AS	0.034	16	26	36
		PABO 1636 PP AS	0.028	16	26	36
20	PAB 2045 PP AS	PABO 2045 PP AS	0.068	20	32	45
		PABO 2045 PP AS	0.058	20	32	45
25	PAB 2558 PP AS	PABO 2558 PP AS	0.132	25	40	58
		PABO 2558 PP AS	0.113	25	40	58
30	PAB 3068 PP AS	PABO 3068 PP AS	0.169	30	47	68
		PABO 3068 PP AS	0.143	30	47	68
40	PAB 4080 PP AS	PABO 4080 PP AS	0.426	40	62	80
		PABO 4080 PP AS	0.362	40	62	80
50	PAB 50100 PP AS	PABO 50100 PP AS	0.773	50	75	100
		PABO 50100 PP AS	0.657	50	75	100

- 1) The tolerances are valid for series PAB..PP AS only.
- 2) Bores and grooves centered on bearing width C.
- 3) Groove dimensions suitable for circlips to DIN 471.
- 4) Dimension A₆ on diameter d.
- 5) The basic static load ratings stated here are not valid if the above elements are fitted in housings – as shown on the following pages.

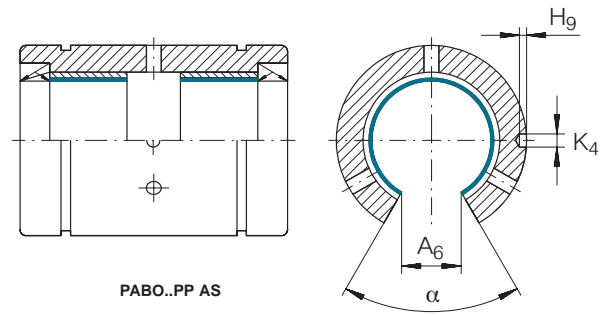

MOUNTING DIMENSIONS								BASIC LOAD RATINGS ⁵⁾	SHAFT DIAMETER
C ₁ ²⁾ H13	C ₇ ³⁾ H13	D ₁	A ₆ ⁴⁾	H ₉	K ₄ ³⁾	K ₈ ³⁾ H13	α Grad	stat. C ₀ N	
22.6	1.3	21	–	–	–	2.5	–	60,000	12
22.6	1.3	21	7.7	1.2	2.2	2.5	78	60,000	
24.6	1.3	24.9	–	–	–	2.5	–	96,000	16
24.6	1.3	24.9	10.1	1.2	2.2	2.5	78	96,000	
31.2	1.6	30.3	–	–	–	2.5	–	150,000	20
31.2	1.6	30.3	10	1.2	2.2	2.5	60	150,000	
43.7	1.85	37.5	–	–	–	2.5	–	250,000	25
43.7	1.85	37.5	12.5	1.5	3	2.5	60	250,000	
51.7	1.85	44.5	–	–	–	3	–	375,000	30
51.7	1.85	44.5	13.6	1.5	3	3	54	375,000	
60.3	2.15	59	–	–	–	3	–	600,000	40
60.3	2.15	59	18.2	1.5	3	3	54	600,000	
77.3	2.65	72	–	–	–	4	–	1,000,000	50
77.3	2.65	72	22.7	1.5	3	4	54	1,000,000	

Permaglide® Linear Plain Bearing Units

PAGBA..PP AS, PAGBAO..PP AS SERIES

- Plain Bearing Range
- Sealed, Greased, With Relubrication Facility

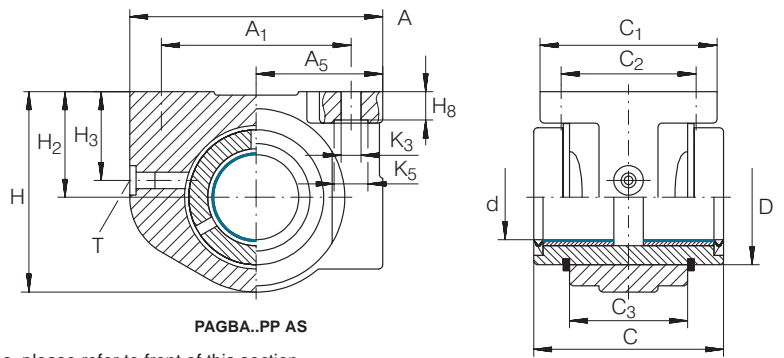

PAGBA..PP AS

For details on part numbers, descriptive suffixes and various technical references, please refer to front of this section.

For engineering or technical information contact your local sales representative or call Distributor Sales (800)523-6572 or Linear Sales (800)462-3399.

DIMENSION TABLE · Dimensions in mm

SHAFT DIAMETER	PART NUMBER		MASS	DIMENSIONS				MOUNTING DIMENSIONS		
				d	A	C	H	A ₁	A ₅	A ₆ ¹⁾
			kg			h12				
12	PAGBA 1232 PP AS	–	0.07	12	42	32	34	32 ^{±0.15}	21 ^{±0.01}	–
	–	PAGBAO 1232 PP AS	0.06	12	42	32	–	32 ^{±0.15}	21	7.7
16	PAGBA 1636 PP AS	–	0.1	16	50	36	41	40 ^{±0.15}	25 ^{±0.01}	–
	–	PAGBAO 1636 PP AS	0.09	16	50	36	–	40 ^{±0.15}	25	10.1
20	PAGBA 2045 PP AS	–	0.18	20	60	45	47.5	45 ^{±0.15}	30 ^{±0.01}	–
	–	PAGBAO 2045 PP AS	0.16	20	60	45	–	45 ^{±0.15}	30	10
25	PAGBA 2558 PP AS	–	0.35	25	74	58	60	60 ^{±0.2}	37 ^{±0.01}	–
	–	PAGBAO 2558 PP AS	0.31	25	74	58	–	60 ^{±0.2}	37	12.5
30	PAGBA 3068 PP AS	–	0.48	30	84	68	67	68 ^{±0.2}	42 ^{±0.01}	–
	–	PAGBAO 3068 PP AS	0.43	30	84	68	–	68 ^{±0.2}	42	13.6
40	PAGBA 4080 PP AS	–	1.07	40	108	80	87	86 ^{±0.2}	54 ^{±0.015}	–
	–	PAGBAO 4080 PP AS	0.91	40	108	80	–	86 ^{±0.2}	54	18.2
50	PAGBA 50100 PP AS	–	1.65	50	130	100	98	108 ^{±0.2}	65 ^{±0.015}	–
	–	PAGBAO 50100 PP AS	1.46	50	130	100	–	108 ^{±0.2}	65	22.7

1) Dimension A₆ on diameter d.

2) The tolerances are valid for series PAGBA..PP AS only.

3) For fixing screws to DIN 912-8.8 and spring washer to DIN 7 980.

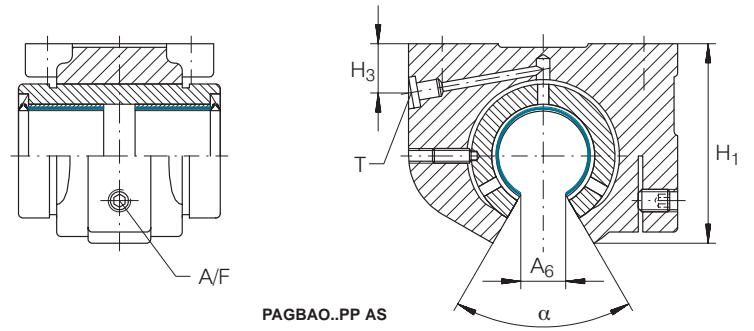

												INA LUBRICATION NIPPLE ⁴⁾	SHAFT DIAMETER
C ₁	C ₂	C ₃	D ²⁾ h7	H ₁	H ₂	H ₃	H ₈ -0.5	K ₃ ³⁾	K ₅ ³⁾	A/F	α Grad	T	
32	23±0.15	20	22	–	18±0.01	15	4.8	4.7	8	–	–	NIP A1	12
32	23±0.15	20	22	30.5	18	7.8	4.8	4.7	8	2	78	NIP A1	
35	26±0.15	22	26	–	22±0.01	15	5.4	4.7	8	–	–	NIP A1	16
35	26±0.15	22	26	36.8	22	10	5.4	4.7	8	2.5	78	NIP A1	
42	32±0.15	28	32	–	25±0.01	21	6.7	4.7	8	–	–	NIP A1	20
42	32±0.15	28	32	44.5	25	11	6.7	4.7	8	2.5	60	NIP A1	
54	40±0.2	40	40	–	30±0.01	23	7.8	5.7	10	–	–	NIP A1	25
54	40±0.2	40	40	56	30	13	7.8	5.7	10	3	60	NIP A1	
60	45±0.2	48	47	–	35±0.01	25	8.7	6.8	11	–	–	NIP A2	30
60	45±0.2	48	47	63.5	35	14	8.7	6.8	11	3	54	NIP A2	
78	58±0.2	56	62	–	45±0.01	30	11	9.2	15	–	–	NIP A2	40
78	58±0.2	56	62	82.4	45	18	11	9.2	15	4	54	NIP A2	
70	50±0.2	72	75	–	50±0.015	34	12.5	9.2	15	–	–	NIP A2	50
70	50±0.2	72	75	92.8	50	19	12.5	9.2	15	4	54	NIP A2	

Shafts W SERIES

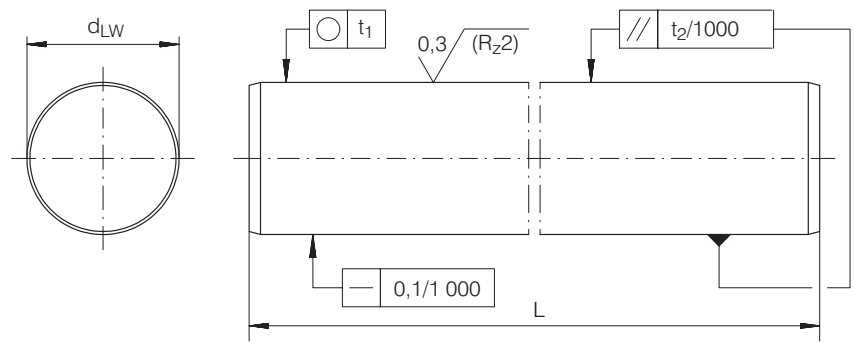

For details on part numbers, descriptive suffixes and various technical references, please refer to front of this section.

For engineering or technical information contact your local sales representative or call Distributor Sales (800)523-6572 or Linear Sales (800)462-3399.

DIMENSION TABLE - Dimensions in mm

SHAFT DIAMETER d_{LW}	PART NUMBER	MASS kg/m	LENGTH L_{max}	TOLERANCES IN μm			ROUNDNESS t_1 μm	PARALLELISM $t_2^2)$ μm	SURFACE HARDNESS DEPTH RHT ³⁾ min.
				STANDARD TOLERANCE h6	SPECIAL TOLERANCES ¹⁾				
					j5	f7			
5	W 5	0.15	3,600	0-8	-	-	4	5	0.4
6	W 6	0.22	4,000	0-8	-	-	4	5	0.4
8	W 8	0.39	4,000	0-9	-	-	4	6	0.4
10	W 10	0.61	6,000	0-9	-	-	4	6	0.4
12	W 12	0.89	6,000	0-11	+5-3	-16-34	5	8	0.6
14	W 14	1.21	6,000	0-11	+5-3	-16-34	5	8	0.6
15	W 15	1.37	6,000	0-11	-	-16-34	5	8	0.6
16	W 16	1.57	6,000	0-11	+5-3	-16-34	5	8	0.6
18	W 18	1.98	6,000	0-11	-	-16-34	5	8	0.6
20	W 20	2.45	6,000	0-13	+5-4	-20-41	6	9	0.9
24	W 24	3.55	6,000	0-13	-	-	6	9	0.9
25	W 25	3.83	6,000	0-13	+5-4	-20-41	6	9	0.9
30	W 30	5.51	6,000	0-13	+5-4	-20-41	6	9	0.9
32	W 32	6.3	6,000	0-16	-	-25-50	7	11	1.5
40	W 40	9.8	6,000	0-16	+6-5	-	7	11	1.5
50	W 50	15.3	6,000	0-16	+6-5	-	7	11	1.5
60	W 60	22.1	6,000	0-19	-	-	8	13	2.2
80	W 80	39.2	6,000	0-19	-	-	8	13	2.2

1) Only for shafts made from quenched and tempered steel.

2) Measured diameter variation.

3) According to DIN 6 773, Part 3.

Recommended Threaded Holes

Recommended threaded holes for shafts W

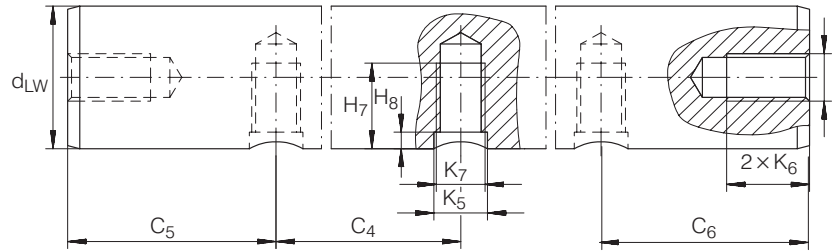

For details on part numbers, descriptive suffixes and various technical references, please refer to front of this section.

For engineering or technical information contact your local sales representative or call Distributor Sales (800)523-6572 or Linear Sales (800)462-3399.

DIMENSION TABLE - Dimensions in mm																	
PART NUMBER ¹⁾	AXIAL THREAD									RADIAL THREAD							
	K ₆									DIMENSIONS							
										C ₄		C _{5min} , C _{6min} ²⁾ HOLE PATTERN		H ₇	H ₈	K ₅	K ₇
								03	04-05								
W 5																	
W 6																	
W 8	M3																
W 10	M3	M4															
W 12		M4	M5					75	120	10			8	2	5	M4	
W 14		M4	M5	M6													
W 15			M5	M6	M8												
W 16			M5	M6	M8			75	100	150	10			9	2.5	6	M5
W 18				M6	M8	M10											
W 20										150	10			9	2.5	6	M5
W 24				M6	M8	M10	M12	75	100	150	15			11	3	7	M6
W 25										150	15	3 x K ₆ + K ₇					
				M8	M10	M12		75	120	200	15			11	3	7	M6
										150	15			15	3	9	M8
W 30										150	15			11	3	7	M6
					M10	M12	M16	100	150	200	20			17	3.5	11	M10
W 32					M10	M12	M16										
W 40					M10	M12	M16	150	200	300	20			19	4	11	M10
					M10	M12	M16	100			20			21	4	13	M12
W 50										150	20			19	4	11	M10
						M12	M16	M20			20			21	4	13	M12
						M12	M16	M20	100	200	300	20		25	4	15	M14
W 60																	
W 80																	

²⁾ The dimensions C₅ and C₆ are dependent on the length of the shaft.
The axial threaded holes should be taken into consideration when using hole patterns 04 and 05.

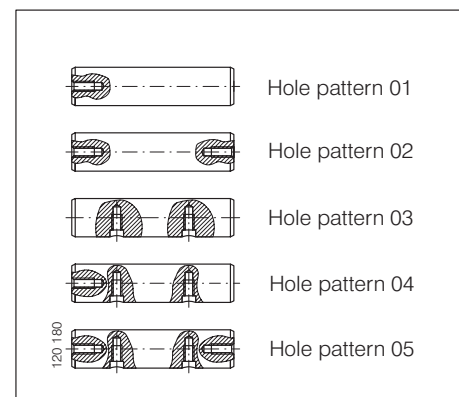

Shafts

WH SERIES

- Hollow shafts

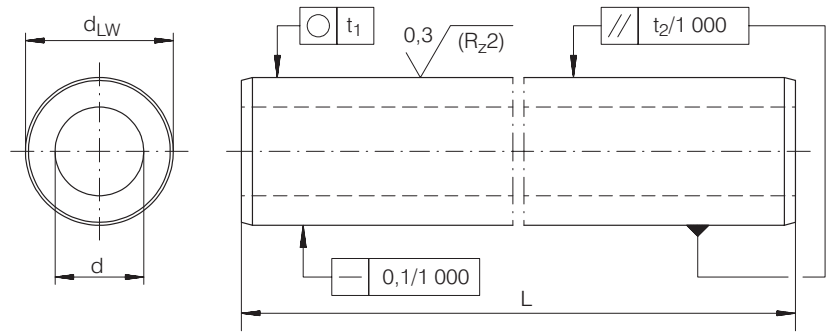

For details on part numbers, descriptive suffixes and various technical references, please refer to front of this section.

For engineering or technical information contact your local sales representative or call Distributor Sales (800)523-6572 or Linear Sales (800)462-3399.

DIMENSION TABLE - Dimensions in mm

SHAFT DIAMETER d_{LW}	PART NUMBER	MASS kg/m	Length L	INSIDE DIAMETER $d^1)$	TOLERANCES IN MM D h7	ROUNDNESS t_1 μm	PARALLELISM $t_2^2)$ μm	SURFACE HARDNESS DEPTH $R_{ht}^3)$ min.
20	WH 20	1.25	6,000	14	0-21	6	9	0.9
25	WH 25	2.35	6,000	15.6	0-21	6	9	0.9
30	WH 30	3.5	6,000	18.2	0-21	6	9	0.9
40	WH 40	4.99	6,000	28.1	0-25	7	11	1.5
50	WH 50	9.97	6,000	29.7	0-25	7	11	1.5
60	WH 60	14.2	6,000	36	0-30	8	13	2.2
80	WH 80	19.5	6,000	56.9	0-30	8	13	2.2

1) Wall thickness tolerance of initial material: $\pm 4\%$.

2) Measured diameter variation.

3) According to DIN 6 773. Part 3.

Shaft And Support Rail Units

TSWW, TSNW SERIES

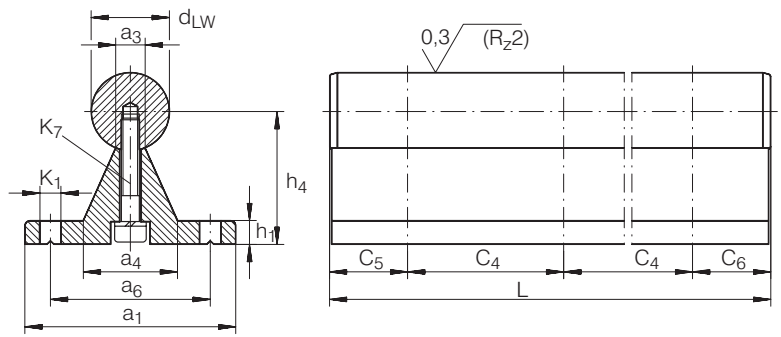

For details on part numbers, descriptive suffixes and various technical references, please refer to front of this section.

For engineering or technical information contact your local sales representative or call Distributor Sales (800)523-6572 or Linear Sales (800)462-3399.

DIMENSION TABLE - Dimensions in mm														
SHAFT DIAMETER d_{LW}	PART NUMBER	MASS kg/m	DIMENSIONS			MOUNTING DIMENSIONS								
			a_1	$h_4^{1)}$ ± 0.02	$L^2)$ ± 3	a_3	a_4	a_6	C_4	$C_5/C_6^3)$ min.	$C_5/C_6^3)$ max.	h_1	$K_1^4)$	K_7 DIN 6 912
12	TSWW 12	1.67	40	22	6,000	6	19.5	29	120	20	114	5	4.5	M4 × 20
	TSNW 12	1.67	40	22	6,000	5.4	15	29	75	20	69	5	4.5	M4 × 20
16	TSWW 16	3.15	54	32	6,000	7.5	24.2	41	150	20	143	6	5.5	M5 × 30
	TSNW 16	2.95	45	26	6,000	7	19	33	100	20	93	5	5.5	M5 × 20
20	TSWW 20	4.03	54	34.02	6,000	7.5	24.2	41	150	20	143	6	5.5	M5 × 30
	TSNW 20	3.95	52	32	6,000	8.1	23	37	100	20	92	6	6.6	M6 × 25
25	TSWW 25	5.9	65	39.66	6,000	10	29.8	51	150	20	142	6	6.6	M6 × 35
	TSNW 25	5.6	57	36	6,000	10.3	26	42	120	20	110	6	6.6	M8 × 30
30	TSWW 30	7.58	65	42.19	6,000	10	29.8	51	150	20	142	6	6.6	M6 × 35
	TSNW 30	7.88	69	42	6,000	11	29	51	150	20	139	7	9	M10 × 35
40	TSWW 40	14.25	85	60	6,000	17	46	65	150	20	139	10	9	M10 × 50
	TSNW 40	12.83	73	50	6,000	15	36	55	200	20	189	8	9	M10 × 40
50	TSWW 50	19.75	85	65.05	6,000	17	46	65	150	20	139	10	9	M10 × 50
	TSNW 50	19.38	84	60	6,000	19	40	63	200	20	188	9	11	M12 × 45

- 1) With reference to the nominal shaft diameter. measured while clamped.
- 2) Maximum length of single piece shaft and support rail units:
Depending on the length of the shaft and support rail unit,
the rail is composed of several individual sections.
- 3) The dimensions C_5 and C_6 are dependent on the length of the shaft and support rail unit.
- 4) TSWW: for fixing screws to DIN 912 or DIN 933 (TSWW 12, DIN 6 912)
and spring washer or washer to DIN 7 980 or DIN 125.
TSNW: for fixing screws to DIN 6 912 and spring washer to DIN 7 980.

Shaft And Support Rail Unit

TSUW SERIES

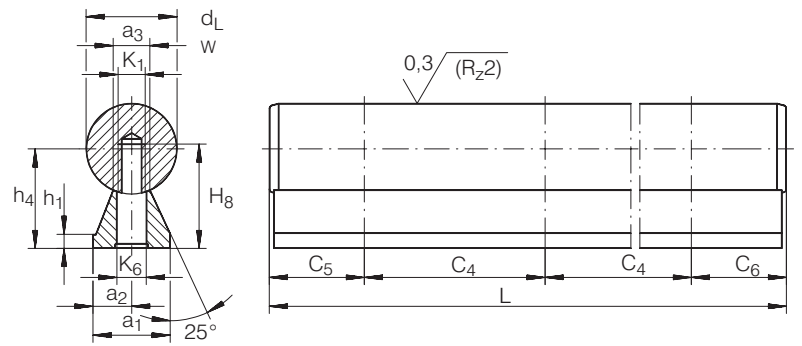

For details on part numbers, descriptive suffixes and various technical references, please refer to front of this section.

For engineering or technical information contact your local sales representative or call Distributor Sales (800)523-6572 or Linear Sales (800)462-3399.

DIMENSION TABLE - Dimensions in mm

SHAFT DIAMETER d_{LW}	PART NUMBER	MASS kg/m	DIMENSIONS			MOUNTING DIMENSIONS								
			a_1	$h_4^{1)}$ ± 0.02	$L^2)$ ± 3	$a_2^{3)}$	a_3	C_4	$C_5/C_6^4)$ min.	$C_5/C_6^4)$ max.	h_1	K_1	K_6	H_8
12	TSUW 12	1.1	11	14.5	6,000	5.5	5.4	75	20	70	3	M4	4.5	16
16	TSUW 16	1.88	14	18	6,000	7	7	75	20	70	3	M5	5.5	19
20	TSUW 20	2.92	17	22	6,000	8.5	8.1	75	20	69	3	M6	6.6	23
25	TSUW 25	4.42	21	26	6,000	10.5	10.3	75	20	68	3	M8	9	28.5
30	TSUW 30	6.22	23	30	6,000	11.5	11	100	20	92	3	M10	11	32
40	TSUW 40	11.03	30	39	6,000	15	15	100	20	91	4	M12	13.5	39.5
50	TSUW 50	16.98	35	46	6,000	17.5	19	100	20	90	5	M14	15.5	46

1) With reference to the nominal shaft diameter, measured while clamped.

2) Maximum length of single piece shaft and support rail units (TSUW 12: $L = 1,600 \pm 1.2$ mm);
Depending on the length of the shaft and support rail unit,
the rail is composed of several individual sections.

3) Available on request with $a_2 \pm 0.02$.

4) The dimensions C_5 and C_6 are dependent on the length of the shaft and support rail unit.

Shaft And Support Rail Units

TSNW..G4 $d \leq 25$ mm,
TSNW..G5 $d > 25$ mm SERIES

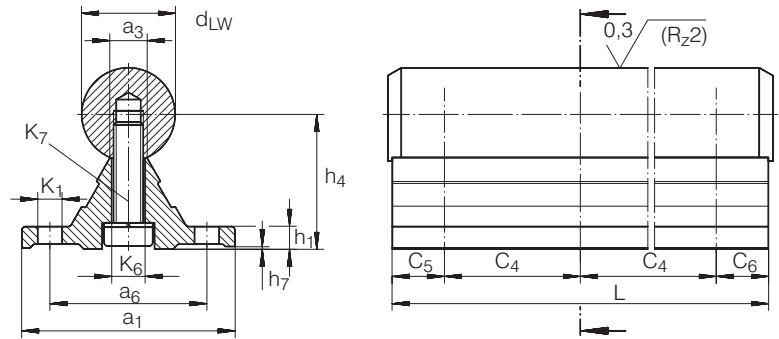

For details on part numbers, descriptive suffixes and various technical references, please refer to front of this section.

For engineering or technical information contact your local sales representative or call Distributor Sales (800)523-6572 or Linear Sales (800)462-3399.

DIMENSION TABLE - Dimensions in mm																
SHAFT DIAMETER d_{LW}	PART NUMBER	MASS kg/m	DIMENSIONS			MOUNTING DIMENSIONS										
			a_1	$h_4^{1)}$	$L^{2)}$ ± 2	a_3	a_6	C_4	$C_5/C_6^{3)}$ min.	$C_5/C_6^{3)}$ max.	h_1	h_7	$K_1^{4)}$	K_6	K_7 DIN 6 912	ACCURACY CLASS ⁵⁾
12	TSNW 12 G4	1.6	40	22 ± 0.1	4,000	5	29	75	20	69	5	0.2	4.5	4.5	M4 × 18	G4 0.03
16	TSNW 16 G4	2.5	45	26 ± 0.1	4,000	6.8	33	100	20	93	5	0.2	5.5	5.5	M5 × 20	G4 0.03
20	TSNW 20 G4	3.8	52	32 ± 0.1	4,000	7.8	37	100	20	92	6	0.2	6.6	6.6	M6 × 25	G4 0.03
25	TSNW 25 G4	5.3	57	36 ± 0.1	4,000	9.8	42	120	20	110	6	0.3	6.6	9	M8 × 30	G4 0.03
30	TSNW 30 G5	7.5	69	42 ± 0.15	4,000	11	51	150	20	139	7	0.3	9	11	M10 × 35	G5 0.04
40	TSNW 40 G5	12.4	73	50 ± 0.15	4,000	14.5	55	200	20	189	8	0.3	9	11	M10 × 40	G5 0.04
50	TSNW 50 G5	18.9	84	60 ± 0.15	4,000	18.5	63	200	20	188	9	0.3	11	13.5	M12 × 45	G5 0.05

- 1) With reference to the nominal shaft diameter, measured while clamped.
- 2) Maximum length of single piece shaft and support rail units:
the shaft is longer than the support rail by 2.5 mm at each end.
- 3) The dimensions C_5 and C_6 are dependent on the length of the shaft and support rail unit.
- 4) For fixing screws to DIN 6 912 and spring washer to DIN 7 980.
- 5) Maximum variation of dimension h_4 , measured on the same rail over a distance of 1,000 mm.

Shaft And Support Rail Unit

TSSW SERIES

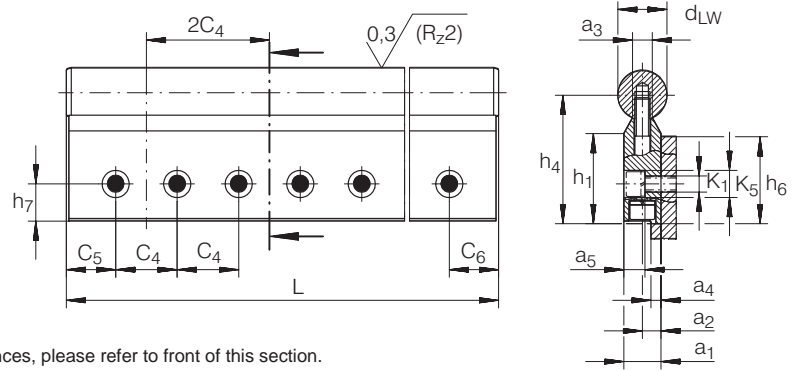

For details on part numbers, descriptive suffixes and various technical references, please refer to front of this section.

For engineering or technical information contact your local sales representative or call Distributor Sales (800)523-6572 or Linear Sales (800)462-3399.

DIMENSION TABLE - Dimensions in mm

SHAFT DIAMETER d_{LW}	PART NUMBER	MASS kg/m	DIMENSIONS			MOUNTING DIMENSIONS											
			a_1	$h_4^{1)}$ ± 0.01	$L^{2)}$ ± 3	$a_2^{1)}$ ± 0.012	a_3	a_4	$a_5^{3)}$	C_4	$C_5/C_6^{4)}$ min.	$C_5/C_6^{4)}$ max.	h_1	h_6	h_7 ± 0.15	$K_1^{3)}$	$K_5^{3)}$
20	TSSW 20	4.12	15	52	6,000	7.5	8.1	4	8.5	50	20	42	36.5	30	15	6.6	11
25	TSSW 25	5.98	20	62	6,000	10	10.3	5.5	11	60	20	50	38.5	36	18	9	15
30	TSSW 30	8.68	25	72	6,000	12.5	11	7	13.5	75	20	64	43	42	21	11	18
40	TSSW 40	14.3	30	88	6,000	15	15	8.5	16	100	20	88	53	50	25	13.5	20
50	TSSW 50	21.47	35	105	6,000	17.5	19	9	18.5	100	20	86	64.5	60	30	15.5	24

- 1) With reference to the nominal shaft diameter, measured while clamped.
- 2) Maximum length of single piece shaft and support rail units.
Depending on the length of the shaft and support rail unit, the rail is composed of several individual sections.
- 3) For fixing screws to DIN 912-8.8 and spring washer to DIN 7 980.
- 4) The dimensions C_5 and C_6 are dependent on the length of the shaft and support rail unit.

Shaft And Support Rail Unit

TSWWA SERIES

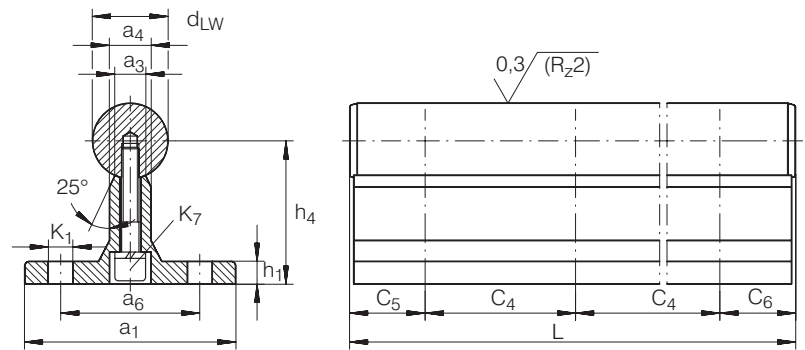

For details on part numbers, descriptive suffixes and various technical references, please refer to front of this section.

For engineering or technical information contact your local sales representative or call Distributor Sales (800)523-6572 or Linear Sales (800)462-3399.

DIMENSION TABLE - Dimensions in mm													
SHAFT DIAMETER d_{LW}	PART NUMBER	MASS kg/m	DIMENSIONS			MOUNTING DIMENSIONS							
			a_1	$h_4^{1)}$ ± 0.02	$L^{2)}$ ± 3	a_3	a_4	a_6	C_4	$C_5/C_6^{3)}$ min.	$C_5/C_6^{3)}$ max.	h_1	$K_1^{4)}$
12	TSWWA 12	1.93	43	28	6,000	5.4	9	29	75	20	69	5	4.5
16	TSWWA 16	2.8	48	30	6,000	7	10	33	100	20	93	5	5.5
20	TSWWA 20	4.12	56	38	6,000	8.1	11	37	100	20	92	6	6.6
25	TSWWA 25	5.83	60	42	6,000	10.3	14	42	120	20	110	6	6.6
30	TSWWA 30	8.5	74	53	6,000	11	14	51	150	20	139	8	9
40	TSWWA 40	13.33	78	60	6,000	15	18	55	200	20	189	8	9
50	TSWWA 50	20.33	90	75	6,000	19	22	63	200	20	188	10	11

- 1) With reference to the nominal shaft diameter, measured while clamped.
- 2) Maximum length of single piece shaft and support rail units.
Depending on the length of the shaft and support rail unit, the rail is composed of several individual sections.
- 3) The dimensions C_5 and C_6 are dependent on the length of the shaft and support rail unit.
- 4) For fixing screws to DIN 912 or DIN 933
and spring washer or washer to DIN 7 980 or DIN 125.

Shaft Support Blocks

GWH..B SERIES

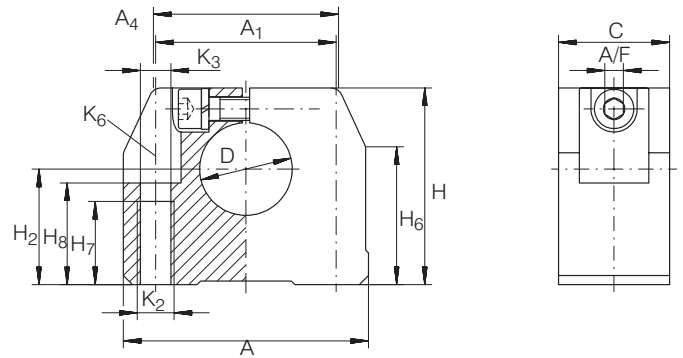

For details on part numbers, descriptive suffixes and various technical references, please refer to front of this section.

For engineering or technical information contact your local sales representative or call Distributor Sales (800)523-6572 or Linear Sales (800)462-3399.

DIMENSION TABLE - Dimensions in mm

SHAFT DIAMETER	PART NUMBER	MASS kg	DIMENSIONS				MOUNTING DIMENSIONS									
			D H8	A	C	H	A ₁ ±0.15	A ₄	H ₂ ±0.01	H ₆	H ₇	H ₈	K ₂	K ₃ ¹⁾	K ₆ ¹⁾	A/F
6	GWH 06 B	0.03	6	32	16	27	22	25	15	19.5	11	13	M5	4.3	M4	2.5
8	GWH 08 B	0.03	8	32	16	27	22	25	16	19.5	11	13	M5	4.3	M4	2.5
10	GWH 10 B	0.05	10	40	18	33	27	32	18	24	13	16	M6	5.3	M5	3
12	GWH 12 B	0.05	12	40	18	33	27	32	19	24	13	16	M6	5.3	M5	3
14	GWH 14 B	0.07	14	43	20	36.5	32	34	20	25.5	13	18	M6	5.3	M5	3
16	GWH 16 B	0.07	16	43	20	36.5	32	34	22	25.5	13	18	M6	5.3	M5	3
20	GWH 20 B	0.12	20	53	24	42.5	39	40	25	28	18	22	M8	6.6	M6	4
25	GWH 25 B	0.17	25	60	28	52.5	44	44	31	33	22	26	M10	8.4	M8	5
30	GWH 30 B	0.22	30	67	30	60	49	49.5	34	41.5	22	29	M10	8.4	M8	5
40	GWH 40 B	0.48	40	87	40	79.5	66	63	42	44.5	26	38	M12	10.5	M10	6
50	GWH 50 B	0.82	50	103	50	92	80	74	50	61	34	46	M16	13.5	M12	8

In the interim, shaft support blocks GWH..B with profile grooves will still be supplied.

1) For fixing screws to DIN 912-8.8 and spring washer to DIN 7980.

Shaft Support Blocks GWN..B SERIES

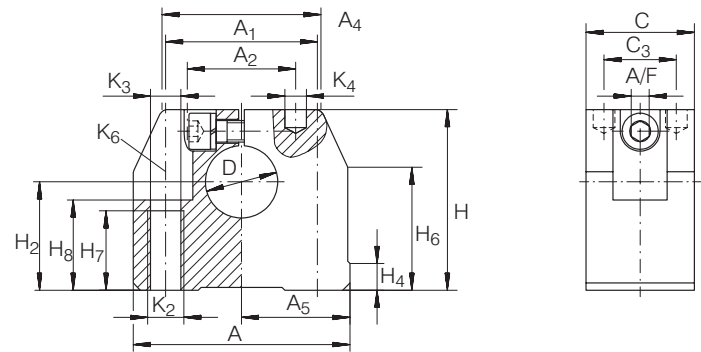

For details on part numbers, descriptive suffixes and various technical references, please refer to front of this section.

For engineering or technical information contact your local sales representative or call Distributor Sales (800)523-6572 or Linear Sales (800)462-3399.

DIMENSION TABLE - Dimensions in mm																					
SHAFT DIAMETER	PART NUMBER	MASS kg	DIMENSIONS				MOUNTING DIMENSIONS														
			D H8	A	C	H	A ₁	A ₂	A ₄	A ₅ ±0.01	C ₃	H ₂ ±0.01	H ₄	H ₆	H ₇	H ₈	K ₂	K ₃	K ₄	K ₆ ¹⁾	A/F
12	GWN 12 B	0.06	12	43	20	35	30±0.15	20	34	21.5	13	20	5.5	26.5	13	16.5	M6	5.3	4	M5	3
16	GWN 16 B	0.1	16	53	24	42	38±0.15	26	40	26.5	16	25	7	29.5	18	21	M8	6.6	5	M6	4
20	GWN 20 B	0.17	20	60	30	50	42±0.15	30	44	30	20	30	7.5	34	22	25	M10	8.4	6	M8	5
25	GWN 25 B	0.33	25	78	38	60	56±0.15	40	59.5	39	25	35	8.5	41.5	26	30	M12	10.5	8	M10	6
30	GWN 30 B	0.45	30	87	40	70	64±0.15	45	63	43.5	26	40	9.5	46	26	34	M12	10.5	8	M10	6
40	GWN 40 B	0.85	40	108	48	90	82±0.15	65	76	54	32	50	11	57.5	34	44	M16	13.5	10	M12	8
50	GWN 50 B	1.4	50	132	58	105	100±0.2	70	90	66	36	60	11	62	43	49	M20	17.5	12	M16	10

In the interim, shaft support blocks GWN..B with profile grooves will still be supplied.

1) For fixing screws to DIN 912-8.8 and spring washer to DIN 7980.

Shaft Support Blocks

GW, GWA SERIES

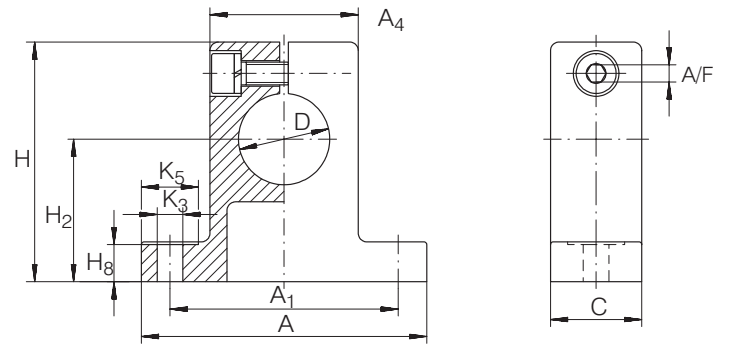

For details on part numbers, descriptive suffixes and various technical references, please refer to front of this section.

For engineering or technical information contact your local sales representative or call Distributor Sales (800)523-6572 or Linear Sales (800)462-3399.

DIMENSION TABLE - Dimensions in mm

SHAFT DIAMETER	PART NUMBER	MASS kg	DIMENSIONS				MOUNTING DIMENSIONS						
			D	A	C	H	A ₁	A ₄	H ₂ ± 0.015	H ₈	K ₃ ¹⁾	K ₅ ¹⁾	A/F
10	GW 10	0.03	10	37	11	30	28 ^{±0.15}	18	17	5	3.4	8	2.5
	GWA 10	0.03	10	37	11	30	28 ^{±0.15}	18	17	5	4.5	9	2.5
12	GW 12	0.04	12	42	12	35	32 ^{±0.15}	20	20	5.5	4.5	10	3
	GWA 12	0.04	12	42	12	35	32 ^{±0.15}	20	20	5.5	5.5	11	3
14	GW 14	0.06	14	46	14	38	36 ^{±0.15}	23	22	6	4.5	10	3
	GWA 14	0.06	14	46	14	38	36 ^{±0.15}	23	22	6	5.5	11	3
16	GW 16	0.08	16	50	16	42	40 ^{±0.15}	26	25	6.5	4.5	10	3
	GWA 16	0.08	16	50	16	42	40 ^{±0.15}	26	25	6.5	5.5	11	3
20	GW 20	0.15	20	60	20	50	45 ^{±0.15}	32	30	7.5	4.5	10	3
	GWA 20	0.15	20	60	20	50	45 ^{±0.15}	32	30	8	5.5	11	3
25	GW 25	0.26	25	74	25	58	60 ^{±0.15}	38	35	8.5	5.5	11	4
	GWA 25	0.26	25	74	25	58	60 ^{±0.15}	38	35	9	6.6	13	4
30	GW 30	0.38	30	84	28	68	68 ^{±0.2}	45	40	9.5	6.6	13	5
	GWA 30	0.38	30	84	28	68	68 ^{±0.2}	45	40	10	9	18	5
40	GW 40	0.67	40	108	32	86	86 ^{±0.2}	56	50	12	9	18	6
	GWA 40	0.67	40	108	32	86	86 ^{±0.2}	56	50	12	11	22	6
50	GW 50	1.38	50	130	40	100	108 ^{±0.2}	80	60	14	9	18	6
	GWA 50	1.38	50	130	40	100	108 ^{±0.2}	80	60	14	11	22	6

1) For fixing screws to DIN 912-8.8 and spring washer to DIN 7980.

Support Rails

TSN..G G4 $d \leq 25$ mm,

TSN..G G5 $d > 25$ mm,

TSN..G4 $d \leq 25$ mm,

TSN..G5 $d > 25$ mm SERIES

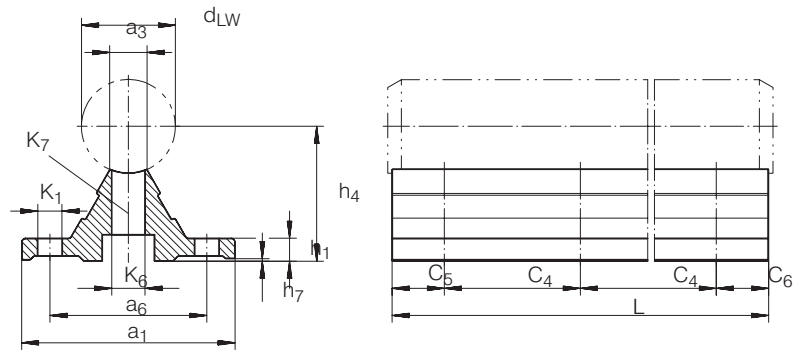

For details on part numbers, descriptive suffixes and various technical references, please refer to front of this section.

For engineering or technical information contact your local sales representative or call Distributor Sales (800)523-6572 or Linear Sales (800)462-3399.

DIMENSION TABLE - Dimensions in mm																
SHAFT DIAMETER d_{LW}	PART NUMBER	MASS kg/m	DIMENSIONS			MOUNTING DIMENSIONS										ACCURACY CLASS ⁵⁾
			a_1	h_4 ¹⁾	L ²⁾ ± 2	a_3	a_6	C_4	C_5/C_6 ³⁾ min. max.		h_1	h_7	K_1 ⁴⁾	K_6	K_7 DIN 6912	
12	TSN 12 G G4	0.72	40	22 ± 0.1	4,000	5	29	75	20	69	5	0.2	4.5	4.5	M4 × 18	G4 0.03
	TSN 12 G4	0.72	40	22 ± 0.1	4,000	5	-	-	-	-	5	0.2	-	-	M4 × 18	G4 0.03
16	TSN 16 G G4	0.88	45	26 ± 0.1	4,000	6.8	33	100	20	93	5	0.2	5.5	5.5	M5 × 20	G4 0.03
	TSN 16 G4	0.93	45	26 ± 0.1	4,000	6.8	-	-	-	-	5	0.2	-	-	M5 × 20	G4 0.03
20	TSN 20 G G4	1.28	52	32 ± 0.1	4,000	7.8	37	100	20	92	6	0.2	6.6	6.6	M6 × 25	G4 0.03
	TSN 20 G4	1.35	52	32 ± 0.1	4,000	7.8	-	-	-	-	6	0.2	-	-	M6 × 25	G4 0.03
25	TSN 25 G G4	1.43	57	36 ± 0.1	4,000	9.8	42	120	20	110	6	0.3	6.6	9	M8 × 30	G4 0.03
	TSN 25 G4	1.47	57	36 ± 0.1	4,000	9.8	-	-	-	-	6	0.3	-	-	M8 × 30	G4 0.03
30	TSN 30 G G5	1.9	69	42 ± 0.15	4,000	11	51	150	20	119	7	0.3	9	11	M10 × 35	G5 0.04
	TSN 30 G5	1.99	69	42 ± 0.15	4,000	11	-	-	-	-	7	0.3	-	-	M10 × 35	G5 0.04
40	TSN 40 G G5	2.53	73	50 ± 0.15	4,000	14.5	55	200	20	189	8	0.3	9	11	M10 × 40	G5 0.04
	TSN 40 G5	2.6	73	50 ± 0.15	4,000	14.5	-	-	-	-	8	0.3	-	-	M10 × 40	G5 0.04
50	TSN 50 G G5	3.46	84	60 ± 0.15	4,000	18.5	63	200	20	188	9	0.3	11	13.5	M12 × 45	G5 0.05
	TSN 50 G5	3.6	84	60 ± 0.15	4,000	18.5	-	-	-	-	9	0.3	-	-	M12 × 45	G5 0.05

1) With reference to the nominal shaft diameter, measured while clamped.

2) Maximum length of support rail.

3) The dimensions C_5 and C_6 are dependent on the length of the shaft and support rail unit.

4) For fixing screws to DIN 6 912 and spring washer to DIN 7 980.

5) Maximum variation of dimension h_4 , measured on the same rail over a distance of 1,000 mm.

Support Rails

TSN..G SERIES

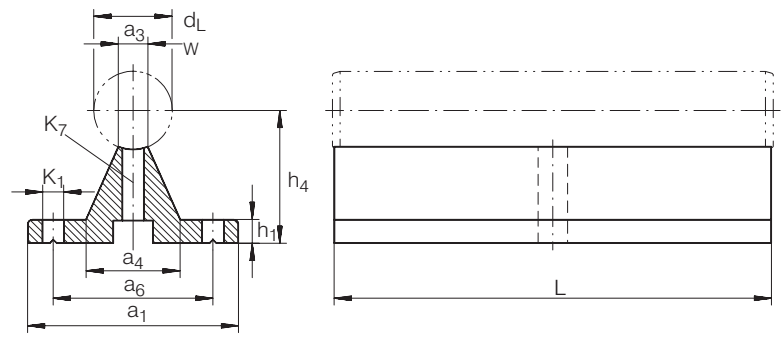

For details on part numbers, descriptive suffixes and various technical references, please refer to front of this section.

For engineering or technical information contact your local sales representative or call Distributor Sales (800)523-6572 or Linear Sales (800)462-3399.

DIMENSION TABLE - Dimensions in mm

SHAFT DIAMETER d_{LW}	PART NUMBER	MASS kg	DIMENSIONS		MOUNTING DIMENSIONS						
			a_1	$h_4^{1)}$	a_3	a_6	L	h_1	$K_1^{2)}$	K_7 DIN 6 912	
h6											
12	TSN 1250 G	0.04	40	22 ± 0.02	5.4	29	50	5	4.5	M4 × 20	
16	TSN 1660 G	0.07	45	26 ± 0.02	7	33	60	5	5.5	M5 × 20	
20	TSN 2070 G	0.1	52	32 ± 0.02	8.1	37	70	6	6.6	M6 × 25	
25	TSN 2580 G	0.15	57	36 ± 0.02	10.3	42	80	6	6.6	M8 × 30	
30	TSN 3090 G	0.19	69	42 ± 0.02	11	51	90	7	9	M10 × 35	
40	TSN 40120 G	0.3	73	50 ± 0.02	15	55	120	8	9	M10 × 40	
50	TSN 50150 G	0.6	84	60 ± 0.02	19	63	150	9	11	M12 × 45	

1) With reference to the nominal shaft diameter, measured while clamped.

2) For fixing screws to DIN 6 912 and spring washer to DIN 7 980.

Linear Ball Bearings

KBZ..(PP) SERIES

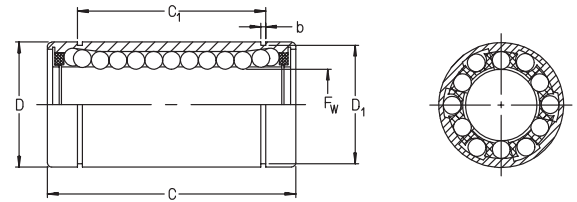

For details on part numbers, descriptive suffixes and various technical references, please refer to front of this section.

For engineering or technical information contact your local sales representative or call Distributor Sales (800)523-6572 or Linear Sales (800)462-3399.

PART NUMBER ⁵⁷⁶	SEAL SUFFIX	SHAFT DIA. inch	WGT. lbs.	F _w inch	D inch	C inch	D ₁ inch	b inch	C ₁ inch	NO. BALL ROWS	LOAD RATINGS dyn. lbf.
KBZ 04	PP	1/4	0.02	0.250	0.500	0.750	0.469	0.039	0.511	4	48
KBZ 06	PP	3/8	0.03	0.375	0.625	0.875	0.588	0.039	0.636	4	54
KBZ 08	PP	1/2	0.08	0.500	0.875	1.250	0.821	0.046	0.963	4	158
KBZ 10	PP	5/8	0.17	0.625	1.125	1.500	1.059	0.056	1.104	4	231
KBZ 12	PP	3/4	0.21	0.750	1.250	1.625	1.176	0.056	1.166	5	287
KBZ 16	PP	1	0.66	1.000	1.563	2.250	1.469	0.068	1.755	6	417
KBZ 20	PP	1-1/4	0.97	1.250	2.000	2.625	1.886	0.068	2.005	6	668
KBZ 24	PP	1-1/2	1.48	1.500	2.375	3.000	2.239	0.086	2.412	6	972
KBZ 32	PP	2	2.51	2.000	3.000	4.000	2.838	0.103	3.192	6	1800

The dynamic load rating is based on a travel life expectancy of 2×10^6 inches.

Linear Ball Bearings

KBZ..OP (PP) SERIES

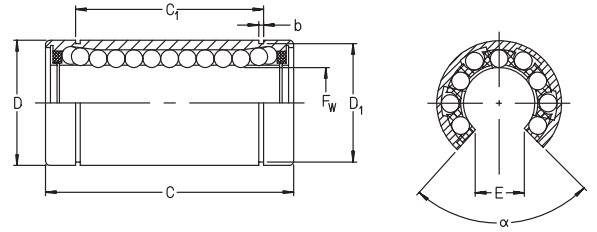

For details on part numbers, descriptive suffixes and various technical references, please refer to front of this section.

For engineering or technical information contact your local sales representative or call Distributor Sales (800)523-6572 or Linear Sales (800)462-3399.

PART NUMBER	SEAL SUFFIX	SHAFT DIA. inch	WGT. lbs.	F _w Nom. Dim. inch	D Nom. Dim. inch	C Nom. Dim. inch	D ₁ inch	b inch	C ₁ Nom. Dim. inch	E inch	a deg	NO. BALL ROWS	LOAD RATINGS dyn. lbf.
KBZ 08 OP	PP	1/2	0.06	0.500	0.875	1.250	0.821	0.046	0.963	0.313	80	3	158
KBZ 10 OP	PP	5/8	0.13	0.625	1.125	1.500	1.059	0.056	1.104	0.375	80	3	231
KBZ 12 OP	PP	3/4	0.17	0.750	1.250	1.625	1.176	0.056	1.166	0.438	60	4	259
KBZ 16 OP	PP	1	0.37	1.000	1.563	2.250	1.469	0.068	1.755	0.563	50	5	346
KBZ 20 OP	PP	1-1/4	1.26	1.250	2.000	2.625	1.886	0.068	2.005	0.625	50	5	555
KBZ 24 OP	PP	1-1/2	1.26	1.500	2.375	3.000	2.239	0.086	2.412	0.750	50	5	817
KBZ 32 OP	PP	2	2.16	2.000	3.000	4.000	2.838	0.103	3.192	1.000	50	5	1490

The dynamic load rating is based on a travel life expectancy of 2×10^6 inches.

Self Aligning Linear Ball Bearings KNZ..(PP) SERIES

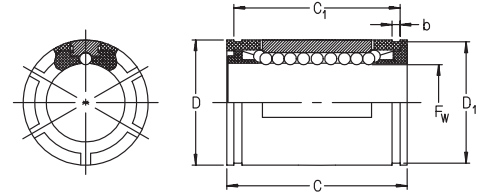

For details on part numbers, descriptive suffixes and various technical references, please refer to front of this section.

For engineering or technical information contact your local sales representative or call Distributor Sales (800)523-6572 or Linear Sales (800)462-3399.

PART NUMBER	SEAL SUFFIX	SHAFT DIA. inch	WGT. lbs.	F _w inch	D inch	C inch	D ₁ inch	b inch	C ₁ inch	NO. BALL ROWS	LOAD RATINGS dyn. lbf.	LOAD RATINGS stat. lbf.
KNZ 04	PP	1/4	0.008	0.250	0.500	0.750	0.469	0.039	0.515	4	50	30
KNZ 06	PP	3/8	0.013	0.375	0.625	0.875	0.588	0.039	0.703	4	80	40
KNZ 08	PP	1/2	0.042	0.500	0.875	1.250	0.821	0.046	1.032	4	200	110
KNZ 10	PP	5/8	0.101	0.625	1.125	1.500	1.059	0.056	1.112	5	340	190
KNZ 12	PP	3/4	0.123	0.750	1.250	1.625	1.176	0.056	1.272	6	480	270
KNZ 16	PP	1	0.265	1.000	1.563	2.250	1.469	0.068	1.886	6	840	490
KNZ 20	PP	1-1/4	0.485	1.250	2.000	2.625	1.886	0.068	2.011	6	1270	710
KNZ 24	PP	1-1/2	0.750	1.500	2.375	3.000	2.239	0.086	2.422	6	1600	850
KNZ 32	PP	2	1.400	2.000	3.000	4.000	2.838	0.103	3.206	6	2600	1460

The dynamic load rating is based on a travel life expectancy of 2×10^6 inches.



Self Aligning Linear Ball Bearings

KNZ..OP (PP) SERIES

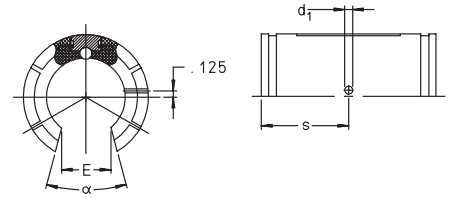

KNZ 08 OP

For details on part numbers, descriptive suffixes and various technical references, please refer to front of this section.

For engineering or technical information contact your local sales representative or call Distributor Sales (800)523-6572 or Linear Sales (800)462-3399.

PART NUMBER	SEAL SUFFIX	SHAFT DIA. inch	WGT. lbs.	F _w inch	D inch	C inch	D ₁ inch	b inch	C ₁ inch	C ₂ inch	E inch	a deg	d ₁ inch	t inch	s inch	NO. BALL ROWS	LOAD RTGS. dyn. lbf.	LOAD RTGS. stat. lbf.
KNZ 08 OP	PP	1/2	0.033	0.500	0.875	1.250	0.821	0.046	1.032	0.063	0.313	30	0.136	—	0.625	3	200	110
KNZ 10 OP	PP	5/8	0.082	0.625	1.125	1.500	1.059	0.056	1.112	0.125	0.375	30	0.105	0.039	0.125	4	390	230
KNZ 12 OP	PP	3/4	0.101	0.750	1.250	1.625	1.176	0.056	1.272	0.125	0.438	30	0.136	0.059	0.125	5	480	280
KNZ 16 OP	PP	1	0.220	1.000	1.563	2.250	1.469	0.068	1.886	0.125	0.563	30	0.136	0.047	0.125	5	870	500
KNZ 20 OP	PP	1-1/4	0.400	1.250	2.000	2.625	1.886	0.068	2.011	0.188	0.625	30	0.201	0.090	0.188	5	1300	730
KNZ 24 OP	PP	1-1/2	0.620	1.500	2.375	3.000	2.239	0.086	2.422	0.188	0.750	30	0.201	0.090	0.188	5	1630	870
KNZ 32 OP	PP	2	1.158	2.000	3.000	4.000	2.838	0.103	3.206	0.312	1.000	30	0.265	—	0.312	5	2650	1490

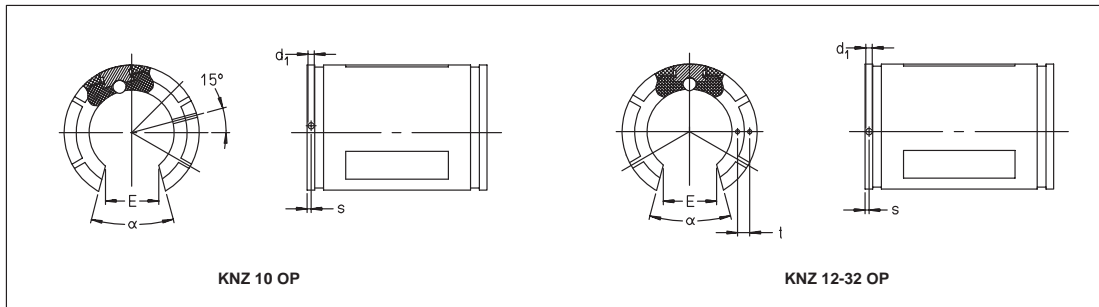

KNZ 10 OP

KNZ 12-32 OP

Self Aligning Mounted Units

KGNZ..PP SERIES

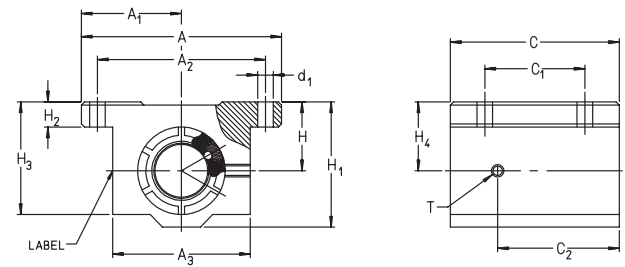

For details on part numbers, descriptive suffixes and various technical references, please refer to front of this section.

For engineering or technical information contact your local sales representative or call Distributor Sales (800)523-6572 or Linear Sales (800)462-3399.

PART NUMBER	SEAL SUFFIX	SHAFT DIA. inch	WGT. lbs.	d inch	A inch	C inch	A ₁ ±.001 inch	H ±.001 inch	A ₃ inch	H ₁ inch	H ₂ inch
KGNZ 04	PP	1/4	0.1	0.25	1.63	1.188	0.813	0.437	1.000	0.813	0.188
KGNZ 06	PP	3/8	0.14	0.375	1.75	1.313	0.875	0.500	1.125	0.938	0.188
KGNZ 08	PP	1/2	0.29	0.500	2.00	1.688	1.000	0.687	1.375	1.250	0.250
KGNZ 10	PP	5/8	0.53	0.625	2.50	1.938	1.250	0.875	1.750	1.625	0.281
KGNZ 12	PP	3/4	0.64	0.750	2.75	2.063	1.375	0.937	1.875	1.750	0.313
KGNZ 16	PP	1	1.36	1.000	3.25	2.813	1.625	1.187	2.375	2.188	0.375
KGNZ 20	PP	1-1/4	2.86	1.250	4.00	3.625	2.000	1.500	3.000	2.813	0.437
KGNZ 24	PP	1-1/2	4.19	1.500	4.75	4.000	2.375	1.750	3.500	3.250	0.500
KGNZ 32	PP	2	7.92	2.000	6.00	5.000	3.000	2.125	4.500	4.063	0.625

PART NUMBER	SEAL SUFFIX	SHAFT DIA. inch	H ₃ inch	C ₂ inch	H ₄ inch	T inch	A ₂ ±.01 inch	C ₁ ±.01 inch	d ₁ inch	DYN. LOAD C lbf	STAT. LOAD C ₀ lbf
KGNZ 04	PP	1/4	0.750	0.590	0.437	NIP A1	1.312	0.750	0.156	50	30
KGNZ 06	PP	3/8	0.875	0.660	0.500	NIP A1	1.437	0.875	0.156	80	40
KGNZ 08	PP	1/2	1.125	0.844	0.690	NIP A1	1.688	1.000	0.156	200	110
KGNZ 10	PP	5/8	1.437	1.260	0.700	1/4-28	2.125	1.125	0.188	340	190
KGNZ 12	PP	3/4	1.563	1.340	0.937	1/4-28	2.375	1.250	0.188	480	270
KGNZ 16	PP	1	1.938	1.950	1.187	1/4-28	2.875	1.750	0.218	840	490
KGNZ 20	PP	1-1/4	2.500	2.430	1.500	1/4-28	3.500	2.000	0.218	1270	710
KGNZ 24	PP	1-1/2	2.875	2.750	1.750	1/4-28	4.125	2.500	0.281	1600	850
KGNZ 32	PP	2	3.625	3.420	2.125	1/4-28	5.250	3.250	0.406	2600	1460

Self Aligning Mounted Units

KGZ..OP PP SERIES

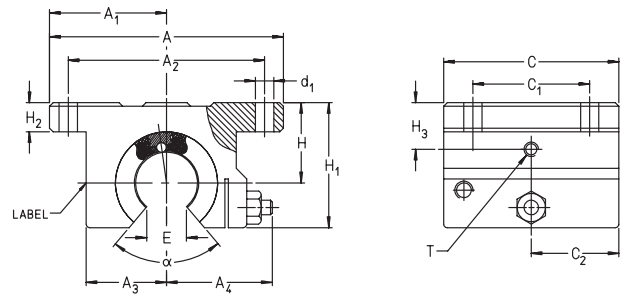

For details on part numbers, descriptive suffixes and various technical references, please refer to front of this section.

For engineering or technical information contact your local sales representative or call Distributor Sales (800)523-6572 or Linear Sales (800)462-3399.

PART NUMBER	SEAL SUFFIX	SHAFT DIA. inch	WGT. lbs.	d inch	A inch	C inch	A ₁ ±.001 inch	H ±.001 inch	A ₃ inch	A ₄ inch	H ₁ inch	H ₂ inch
KGZ OP 08	PP	1/2	0.22	0.500	2.000	1.500	1.000	0.687	0.688	0.905	1.100	0.250
KGZ OP 10	PP	5/8	0.41	0.625	2.500	1.750	1.250	0.875	0.875	1.095	1.375	0.281
KGZ OP 12	PP	3/4	0.52	0.750	2.750	1.875	1.375	0.937	0.937	1.161	1.535	0.313
KGZ OP 16	PP	1	1.17	1.000	3.250	2.625	1.625	1.187	1.188	1.457	1.975	0.375
KGZ OP 20	PP	1-1/4	2.38	1.250	4.000	3.375	2.000	1.500	1.500	1.831	2.485	0.437
KGZ OP 24	PP	1-1/2	3.57	1.500	4.750	3.750	2.375	1.750	1.750	2.087	2.910	0.500
KGZ OP 32	PP	2	6.38	2.000	6.000	4.750	3.000	2.125	2.250	2.638	3.660	0.625

PART NUMBER	SEAL SUFFIX	SHAFT DIA. inch	H ₃ inch	C ₂ inch	T inch	E inch	∞ deg	A ₂ ±.01 inch	C ₁ ±.01 inch	d ₁ inch	DYN. LOAD C lbf	STAT. LOAD C ₀ lbf
KGZ OP 08	PP	1/2	0.370	0.520	NIP A1	0.313	30	1.688	1.00	0.156	200	110
KGZ OP 10	PP	5/8	0.450	0.875	1/4-28	0.375	30	2.125	1.13	0.188	390	230
KGZ OP 12	PP	3/4	0.510	0.937	1/4-28	0.438	30	2.375	1.25	0.188	480	280
KGZ OP 16	PP	1	0.730	1.312	1/4-28	0.563	30	2.875	1.75	0.218	870	500
KGZ OP 20	PP	1-1/4	0.800	1.688	1/4-28	0.625	30	3.500	2.00	0.218	1300	730
KGZ OP 24	PP	1-1/2	0.840	1.875	1/4-28	0.750	30	4.125	2.50	0.281	1630	870
KGZ OP 32	PP	2	1.100	2.375	1/4-28	1.000	30	5.250	3.25	0.406	2650	1490

Self Aligning Tandem Mounted Units KTNZ..PP SERIES

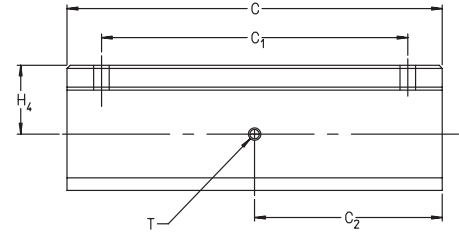
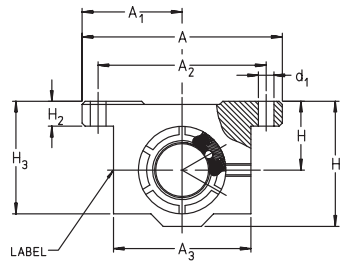

For details on part numbers, descriptive suffixes and various technical references, please refer to front of this section.

For engineering or technical information contact your local sales representative or call Distributor Sales (800)523-6572 or Linear Sales (800)462-3399.

PART NUMBER	SEAL SUFFIX	SHAFT DIA. inch	WGT. lbs.	d inch	A inch	C inch	A ₁ ±.001 inch	H ±.001 inch	A ₃ inch	H ₁ inch	H ₂ inch
KTNZ 04	PP	1/4	0.21	0.250	1.63	2.50	0.813	0.437	1.000	0.813	0.188
KTNZ 06	PP	3/8	0.27	0.375	1.75	2.75	0.875	0.500	1.125	0.938	0.188
KTNZ 08	PP	1/2	0.51	0.500	2.00	3.50	1.000	0.687	1.375	1.250	0.250
KTNZ 10	PP	5/8	0.97	0.625	2.50	4.00	1.250	0.875	1.750	1.625	0.281
KTNZ 12	PP	3/4	1.25	0.750	2.75	4.50	1.375	0.937	1.875	1.750	0.313
KTNZ 16	PP	1	2.58	1.000	3.25	6.00	1.625	1.187	2.375	2.188	0.375
KTNZ 20	PP	1-1/4	4.94	1.250	4.00	7.50	2.000	1.500	3.000	2.813	0.437
KTNZ 24	PP	1-1/2	7.73	1.500	4.75	9.00	2.375	1.750	3.500	3.250	0.500

PART NUMBER	SEAL SUFFIX	SHAFT DIA. inch	H ₃ inch	C ₂ inch	H ₄ inch	T inch	A ₂ ±.01 inch	C ₁ ±.01 inch	d ₁ inch	DYN. LOAD C lbf	STAT. LOAD C ₀ lbf
KTNZ 04	PP	1/4	0.750	1.250	0.437	NIP A1	1.312	2.000	0.156	80	60
KTNZ 06	PP	3/8	0.875	1.375	0.500	NIP A1	1.437	2.250	0.156	130	80
KTNZ 08	PP	1/2	1.125	1.750	0.687	NIP A1	1.688	2.500	0.156	320	220
KTNZ 10	PP	5/8	1.437	2.000	0.875	1/4-28	2.125	3.000	0.188	550	380
KTNZ 12	PP	3/4	1.563	2.250	0.937	1/4-28	2.375	3.500	0.188	780	540
KTNZ 16	PP	1	1.938	3.000	1.187	1/4-28	2.875	4.500	0.218	1360	980
KTNZ 20	PP	1-1/4	2.500	3.750	1.500	1/4-28	3.500	5.500	0.218	2060	1420
KTNZ 24	PP	1-1/2	2.875	4.500	1.750	1/4-28	4.125	6.500	0.281	2600	1700



Self Aligning Tandem Mounted Units KTNZ..OP PP SERIES

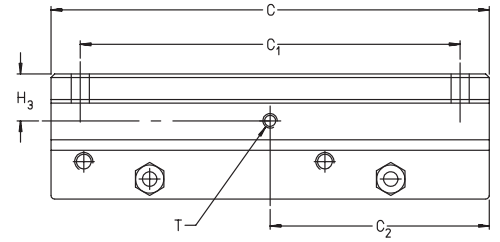
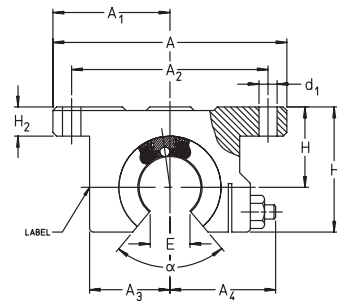

For details on part numbers, descriptive suffixes and various technical references, please refer to front of this section.

For engineering or technical information contact your local sales representative or call Distributor Sales (800)523-6572 or Linear Sales (800)462-3399.

PART NUMBER	SEAL SUFFIX	SHAFT DIA. inch	WGT. lbs.	d inch	A inch	C inch	A ₁ ±.001 inch	H ±.001 inch	A ₃ inch	A ₄ inch	H ₁ inch	H ₂ inch
KTNZ 08 OP	PP	1/2	0.49	0.500	2.000	3.50	1.000	0.687	0.688	0.905	1.100	0.250
KTNZ 10 OP	PP	5/8	0.90	0.625	2.500	4.00	1.250	0.875	0.875	1.095	1.375	0.281
KTNZ 12 OP	PP	3/4	1.15	0.750	2.750	4.50	1.375	0.937	0.937	1.161	1.535	0.313
KTNZ 16 OP	PP	1	2.38	1.000	3.250	6.00	1.625	1.187	1.188	1.457	1.975	0.375
KTNZ 20 OP	PP	1-1/4	4.61	1.250	4.000	7.50	2.000	1.500	1.500	1.831	2.485	0.437
KTNZ 24 OP	PP	1-1/2	7.28	1.500	4.750	9.00	2.375	1.750	1.750	2.087	2.910	0.500

PART NUMBER	SEAL SUFFIX	SHAFT DIA. inch	H ₃ inch	C ₂ inch	T inch	E inch	∞ deg	A ₂ ±.01 inch	C ₁ ±.01 inch	d ₁ inch	DYN. LOAD C lbf	STAT. LOAD C ₀ lbf
KTNZ 08 OP	PP	1/2	0.370	1.75	NIP A1	0.313	30	1.688	2.50	0.156	320	220
KTNZ 10 OP	PP	5/8	0.450	2.00	1/4-28	0.375	30	2.125	3.00	0.188	630	460
KTNZ 12 OP	PP	3/4	0.510	2.25	1/4-28	0.438	30	2.375	3.50	0.188	780	560
KTNZ 16 OP	PP	1	0.730	3.00	1/4-28	0.563	30	2.875	4.50	0.218	1410	1000
KTNZ 20 OP	PP	1-1/4	0.800	3.75	1/4-28	0.625	30	3.500	5.50	0.218	2110	1460
KTNZ 24 OP	PP	1-1/2	0.800	4.50	1/4-28	0.750	30	4.125	6.50	0.281	2650	1740



Precision Ground Shafts

WZ, WZ..X46CR13 SERIES

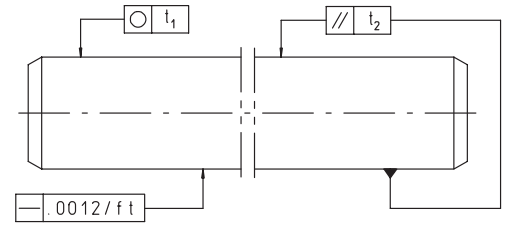
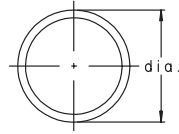

For details on part numbers, descriptive suffixes and various technical references, please refer to front of this section.

For engineering or technical information contact your local sales representative or call Distributor Sales (800)523-6572 or Linear Sales (800)462-3399.

PART NUMBER STANDARD "L" CLASS	PART NUMBER STANDARD "S" CLASS	PART NUMBER STAINLESS STEEL	SHAFT DIA. nom inch	ROUNDNESS t_1 inch	TAPER t_2 ¹⁾ inch	HARDNESS DEPTH min inch	SURFACE FINISHING max
WZ1/4"L	WZ1/4"S	—	1/4	0.0002	0.0002	0.016	RMS 12
WZ3/8"L	WZ3/8"S	WZ3/8"X46CR13L	3/8	0.0002	0.0002	0.016	RMS 12
WZ1/2"L	WZ1/2"S	WZ1/2"X46CR13L	1/2	0.0002	0.0002	0.024	RMS 12
WZ5/8"L	WZ5/8"S	WZ5/8"X46CR13L	5/8	0.0002	0.0003	0.024	RMS 12
WZ3/4"L	WZ3/4"S	WZ3/4"X46CR13L	3/4	0.0002	0.0004	0.035	RMS 12
WZ1"L	WZ1"S	WZ1"X46CR13L	1	0.0002	0.0004	0.035	RMS 12
WZ1-1/8"L	—	—	1-1/8	0.0002	0.0004	0.035	RMS 12
WZ1-1/4"L	WZ1-1/4"S	—	1-1/4	0.0002	0.0004	0.059	RMS 12
WZ1-1/2"L	WZ1-1/2"S	WZ1-1/2"X46CR13L	1-1/2	0.0002	0.0004	0.059	RMS 12
WZ2"L	WZ2"S	—	2	0.0003	0.0004	0.087	RMS 12

1) Measurement of diameter difference



Precision Ground Shafts

WZ..PDT, WZ..X46CR13 PDT SERIES

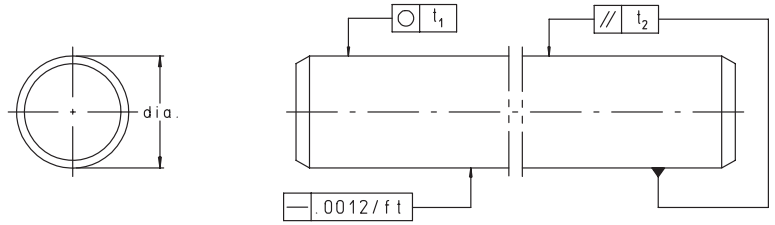

For details on part numbers, descriptive suffixes and various technical references, please refer to front of this section.

For engineering or technical information contact your local sales representative or call Distributor Sales (800)523-6572 or Linear Sales (800)462-3399.

PART NUMBER STANDARD	PART NUMBER STAINLESS STEEL	SHAFT DIA. nom inch	HOLE SPACING X	THREAD SIZE d
WZ1/2" PDT	WZ1/2" X46CR13PDT	1/2	4	6-32
WZ5/8" PDT	—	5/8	4	8-32
WZ3/4" PDT	WZ0-3/4" X46CR13PDT	3/4	6	10-32
WZ1" PDT	WZ1-0/0" X46CR13PDT	1	6	1/4-20
WZ1-1/4" PDT	—	1-1/4	6	5/16-18
WZ1-1/2" PDT	WZ1-1/2" X46CR13PDT	1-1/2	8	3/8-16
WZ2" PDT	—	2	8	1/2-13

Please specify distance from shaft end to first hole with order

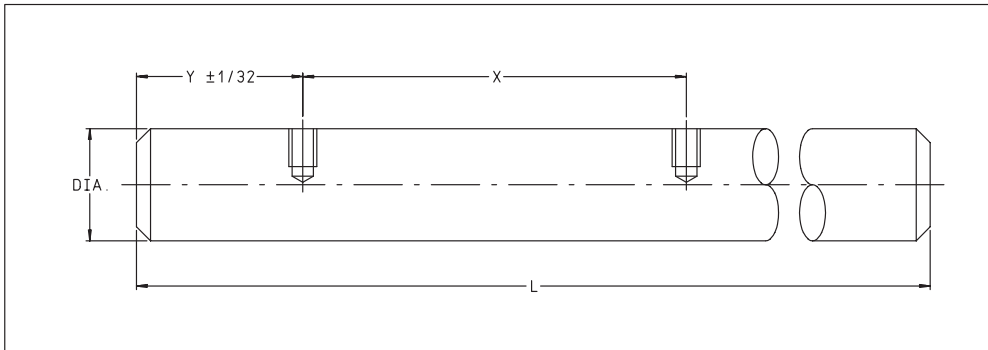

Shaft Support Rails

TSWZ SERIES

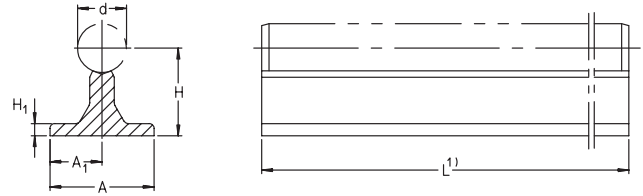

For details on part numbers, descriptive suffixes and various technical references, please refer to front of this section.

For engineering or technical information contact your local sales representative or call Distributor Sales (800)523-6572 or Linear Sales (800)462-3399.

PART NUMBER	SHAFT DIA. inch	WGT. lbsft	A inch	H ²⁾ ± .002 inch	H ₁ inch	A ₁ ³⁾ ± .002 inch
TSWZ 08	1/2	0.60	1.50	1.125	0.188	0.750
TSWZ 10	5/8	0.78	1.63	1.125	0.250	0.813
TSWZ 12	3/4	1.01	1.75	1.500	0.250	0.875
TSWZ 16	1	1.37	2.13	1.750	0.250	1.063
TSWZ 20	1-1/4	1.98	2.50	2.125	0.313	1.250
TSWZ 24	1-1/2	3.03	3.00	2.500	0.375	1.500
TSWZ 32	2	4.80	3.75	3.250	0.500	1.875

1) Maximum length L = 48 inches

2) With reference to the nominal shaft diameter, measured while clamped.

Shaft Support Rails

TSWZ..PD SERIES

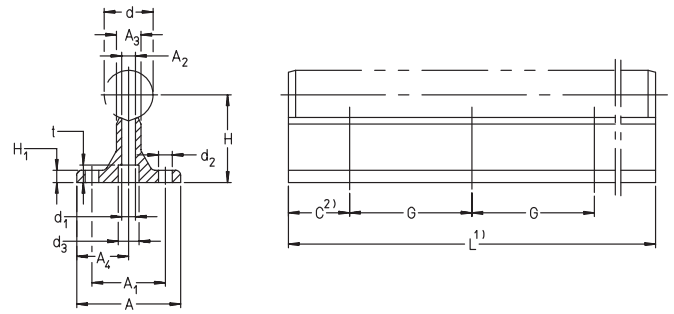

For details on part numbers, descriptive suffixes and various technical references, please refer to front of this section.

For engineering or technical information contact your local sales representative or call Distributor Sales (800)523-6572 or Linear Sales (800)462-3399.

PART NUMBER	SHAFT DIA. inch	WGT. lbs.	A inch	H ³⁾ inch	H ₁ inch	A ₂ inch	A ₃ inch	A ₁ inch	d ₃ inch	t inch	d ₁ inch	d ₂ inch	A ₄ inch	G inch
TSWZ 08 PD	1/2	0.60	1.50	1.125	0.188	0.208	0.250	0.750	0.281	0.150	0.169	0.169	1.000	4
TSWZ 10 PD	5/8	0.78	1.63	1.125	0.250	0.251	0.313	0.813	0.312	0.180	0.193	0.193	1.125	4
TSWZ 12 PD	3/4	1.01	1.75	1.500	0.250	0.294	0.375	0.875	0.375	0.220	0.221	0.221	1.250	6
TSWZ 16 PD	1	1.37	2.13	1.750	0.250	0.379	0.500	1.063	0.437	0.272	0.281	0.281	1.500	6
TSWZ 20 PD	1-1/4	1.98	2.50	2.125	0.313	0.465	0.563	1.250	0.531	0.325	0.343	0.343	1.875	6
TSWZ 24 PD	1-1/2	3.03	3.00	2.500	0.375	0.550	0.688	1.500	0.625	0.390	0.406	0.343	2.250	8
TSWZ 32 PD	2	4.80	3.75	3.250	0.500	0.721	0.875	1.875	0.812	0.540	0.531	0.406	2.750	8

1) Maximum length L = 48 inches

2) The dimension C is dependent on the length of the support rail. It should always be equal at both ends.

3) With reference to the nominal shaft diameter, measured while clamped.



Shaft Support Rails TSUZ SERIES

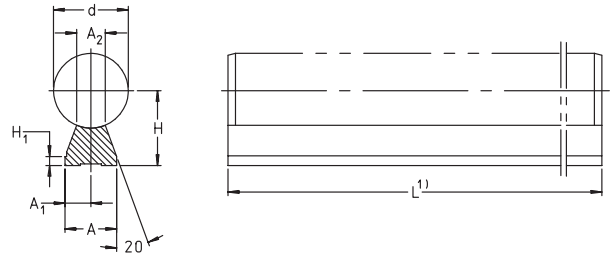

For details on part numbers, descriptive suffixes and various technical references, please refer to front of this section.

For engineering or technical information contact your local sales representative or call Distributor Sales (800)523-6572 or Linear Sales (800)462-3399.

PART NUMBER	SHAFT DIA. inch	WGT. lbsft	d inch	A inch	H ²⁾ ± .002 inch	H ₁ inch	A ₁ ³⁾ ± .002 inch	A ₂ inch
TSUZ 08	1/2	0.11	0.50	0.37	0.562	0.120	0.185	0.216
TSUZ 10	5/8	0.17	0.63	0.45	0.687	0.120	0.225	0.269
TSUZ 12	3/4	0.20	0.75	0.51	0.750	0.120	0.225	0.317
TSUZ 16	1	0.35	1.00	0.69	1.000	0.120	0.345	0.422
TSUZ 20	1-1/4	0.44	1.25	0.78	1.187	0.200	0.390	0.523
TSUZ 24	1-1/2	0.58	1.50	0.93	1.375	0.200	0.465	0.625
TSUZ 32	2	0.89	2.00	1.18	1.750	0.250	0.590	0.824

1) Maximum length L = 48 inches.

2) With reference to the nominal shaft diameter, measured while clamped.



Shaft Support Rails

TSUZ..PD SERIES

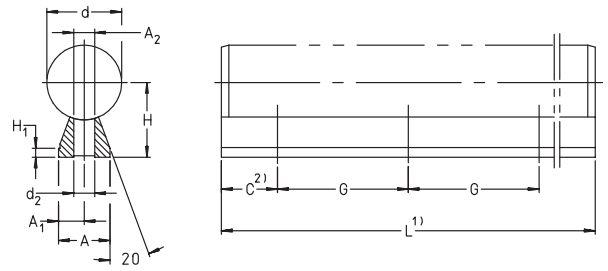

For details on part numbers, descriptive suffixes and various technical references, please refer to front of this section.

For engineering or technical information contact your local sales representative or call Distributor Sales (800)523-6572 or Linear Sales (800)462-3399.

PART NUMBER	SHAFT DIA. inch	WGT. lbs/ft	d inch	A inch	H ₃ inch	H ₁ inch	A ₁ ⁴⁾ inch	A ₂ inch	d ₂ inch	G inch
TSUZ 08 PD	1/2	0.11	0.50	0.37	0.562	0.120	0.185	0.216	0.169	4
TSUZ 10 PD	5/8	0.17	0.63	0.45	0.687	0.120	0.225	0.269	0.193	4
TSUZ 12 PD	3/4	0.20	0.75	0.51	0.750	0.120	0.255	0.317	0.221	6
TSUZ 16 PD	1	0.35	1.00	0.69	1.000	0.120	0.345	0.422	0.281	6
TSUZ 20 PD	1-1/4	0.44	1.25	0.78	1.187	0.200	0.390	0.523	0.343	6
TSUZ 24 PD	1-1/2	0.58	1.50	0.93	1.375	0.200	0.465	0.623	0.406	8
TSUZ 32 PD	2	0.89	2.00	1.18	1.750	0.250	0.590	0.824	0.531	8

1) Maximum length L = 48 inches.

2) The dimension C is dependent on the length of the support rail. It should always be equal at both ends.

3) With reference to the nominal shaft diameter, measured while clamped.

Unitized Compact System

MLFZ SERIES

Rail, Integral Design Carriage

For details on part numbers, descriptive suffixes and various technical references, please refer to front of this section.

For engineering or technical information contact your local sales representative or call Distributor Sales (800)523-6572 or Linear Sales (800)462-3399.

DIMENSION TABLE – Dimensions in mm																			
PART NUMBER	B	B ₁	B ₂	B ₃	D ₁	H	H ₁	H ₂	H ₃	H ₄	H ₅	K ₁	L	L ₁	L ₃	L ₄	L ₅	O	T
MLFZ 20 MI	31.75	19	31.75	19	–	31.8	20.8	–	–	–	–	#6-32	63.5	–	–	–	–	–	–
MLFZ 28 ZR	44.45	31.75	44.45	31.8	26	44.5	33.5	12.7	19.05	9.53	19.05	–	114.3	60	33.88	25.4	8.46	6-32	1.19

PART NUMBER	WEIGHTS			ALLOWABLE LOADS N				ALLOWABLE MOMENTS Nm						MOMENT OF INERTIA		BELT TYPE
	Go g	G100 g	Gc g	Fy	Foy	Fz	Foz	Mx	Mox	My	Moy	Mz	Moz	Iy mm ⁴	Iz mm ⁴	
MLFZ 20 MI	185	121	105	350	350	300	650	2	2.9	3.5	5.8	5.9	5.9	11950	31880	–
MLFZ 28 ZR	720	215	192	350	350	300	650	3.3	4.9	3.5	5.8	5.9	5.9	62300	159900	16T5

1. For maximum lengths please contact factory.
2. Custom carriages can be provided to suit individual requirements.
3. Load ratings valid for fully supported elements.
4. Load ratings not valid for corrosion resistant series.

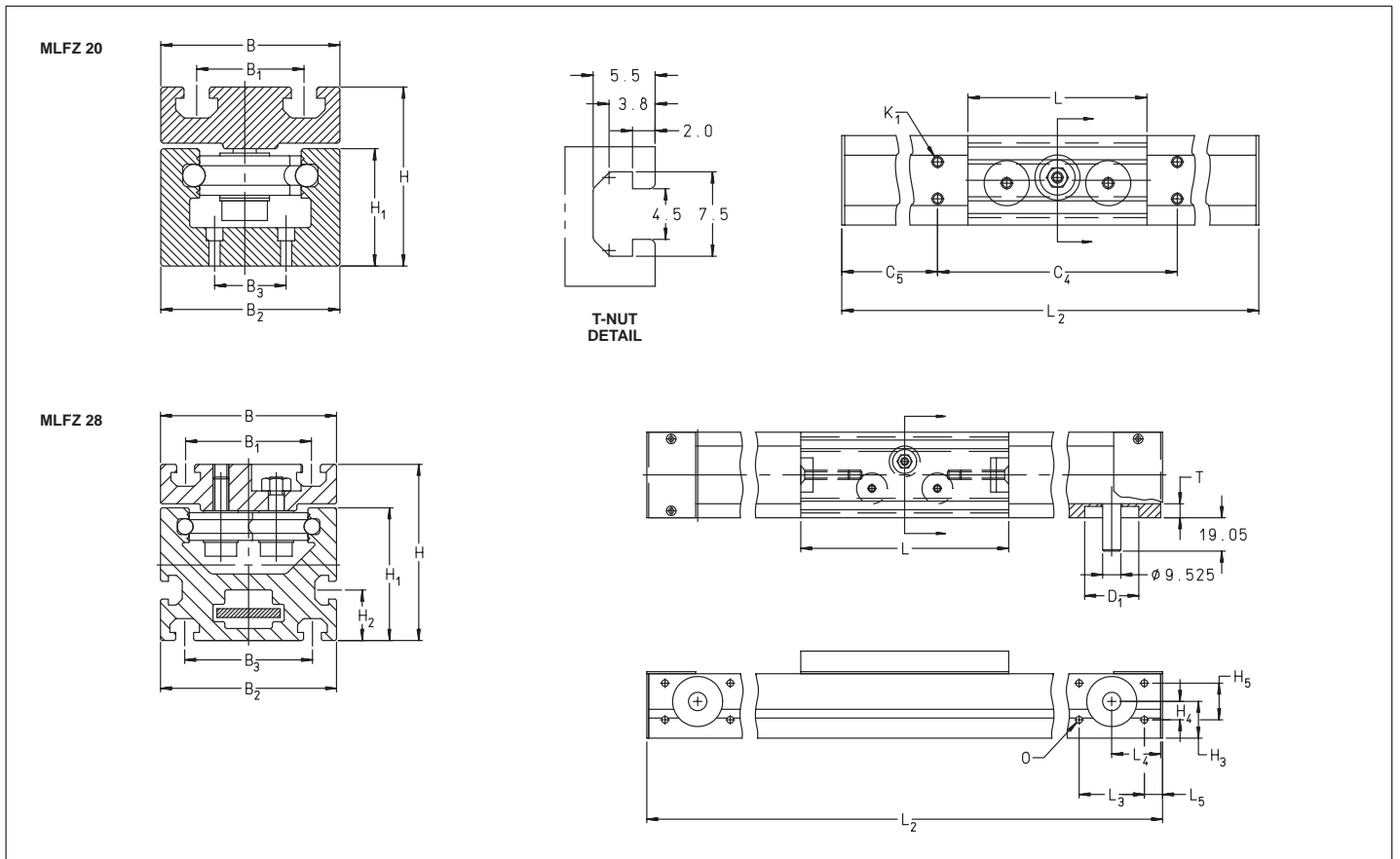

Beam Rail

LFSB SERIES

Standard Carriage

LFL SERIES

For details on part numbers, descriptive suffixes and various technical references, please refer to front of this section.

For engineering or technical information contact your local sales representative or call Distributor Sales (800)523-6572 or Linear Sales (800)462-3399.

DIMENSION TABLE – Dimensions in mm																	
PART NUMBER RAIL	WEIGHT g/m	PART NUMBER CARRIAGE	WEIGHT g	DIMENSIONS						LOAD CALCULATIONS							
				CARRIAGE			RAIL			LOAD CURVE ³⁾	ALLOWABLE LOADS		ALLOWABLE MOMENTS			MOMENT OF INERTIA	
				H	A	C	h	a	L ²⁾		Fy N	Fz N	Mx Nm	My Nm	Mz Nm	Iy mm ⁴	Iz mm ⁴
LFSB 32	9970	LFL 90-80	400	135.6	80	90	120.2	32	4000	2	850	1000	11	30	26	1.485 x 10 ⁶	4.72 x 10 ⁶
LFSB 52	18600	LFL 100-120	1000	177.4	120	100	157.2	52	4000	3	1500	2500	33	75	47	5.25 x 10 ⁶	15.9 x 10 ⁶
LFSB 52	18600	LFL 150-155	1900	183.4	135	150	157.2	52	4000	4	2400	4500	51	105	126	5.25 x 10 ⁶	15.9 x 10 ⁶

MOUNTING DIMENSIONS – Dimensions in mm																	
PART NUMBER RAIL	WEIGHT g/m	PART NUMBER CARRIAGE	A ₁	A ₂	A ₃	a ₁	a ₂	C ₁	C ₂	C ₃	H ₁	H ₂	H ₃	H ₄	h ₅	K ₃	K ₄
LFSB 32	9970	LFL 90-80	59	54	56	63.5	26	7	60	70	35	20.4	14	7	101.6	M6	M8
LFSB 52	18600	LFL 100-120	90	83	65	88.9	42	12	60	70	53.5	29.2	19.5	9.75	127	M6	M10
LFSB 52	18600	LFL 150-135	105	90	65	88.9	42	12	105	110	59	35.2	24	12	127	M6	M10

1. The beam rail is designed as a rigid, light weight beam, suitable for end mounting.
2. Contact factory for longer lengths.
3. Not valid for corrosion resistant series.

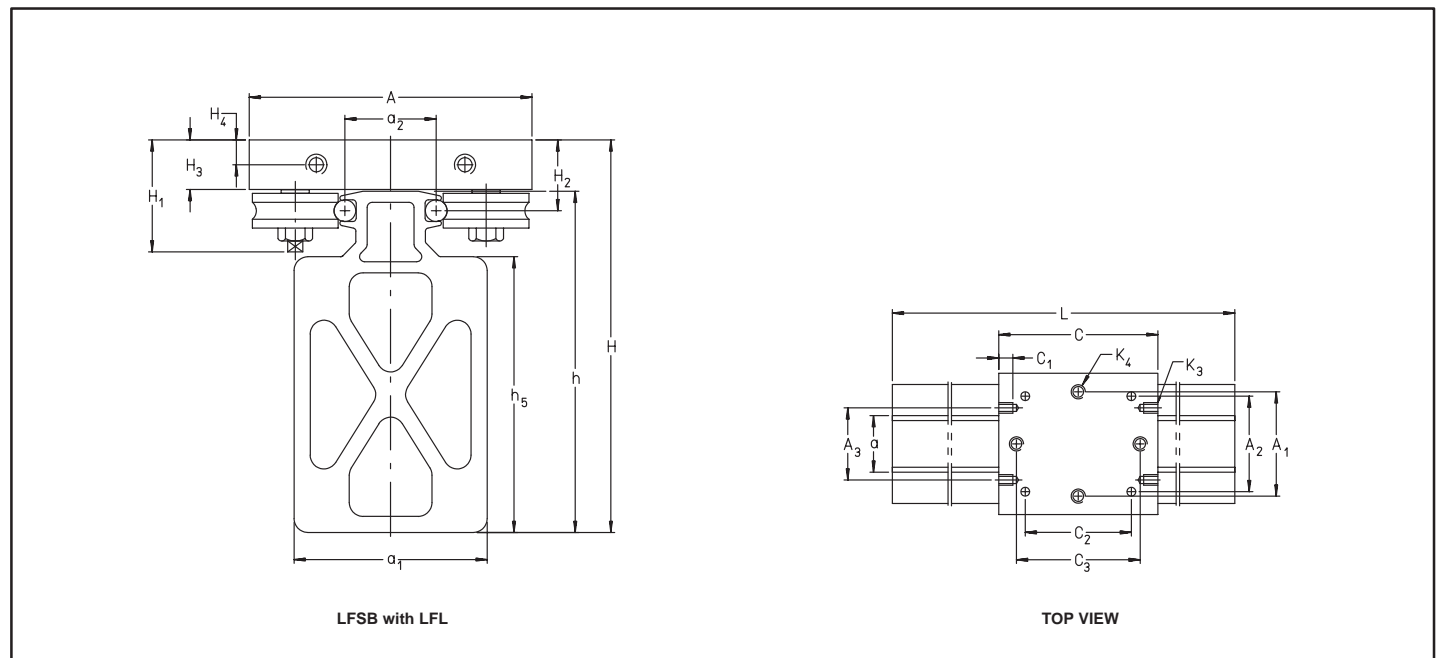

Beam Rail

LFSB SERIES

Enclosed, Sealed Carriage

LFKL SERIES

For details on part numbers, descriptive suffixes and various technical references, please refer to front of this section.

For engineering or technical information contact your local sales representative or call Distributor Sales (800)523-6572 or Linear Sales (800)462-3399.

DIMENSION TABLE – Dimensions in mm																	
PART NUMBER RAIL	WEIGHT g/m	PART NUMBER CARRIAGE	WEIGHT g	DIMENSIONS						LOAD CALCULATIONS							
				CARRIAGE			RAIL			LOAD CURVE 4)	ALLOWABLE LOADS		ALLOWABLE MOMENTS			MOMENT OF INERTIA	
				H	A	C	h	a	L ²⁾		Fy N	Fz N	Mx Nm	My Nm	Mz Nm	ly mm ⁴	lz mm ⁴
LFSB 32	9970	LFKL 112-86	700	135.7	86	112	120.2	32	4000	2	850	1000	11	30	26	1.485 x 10 ⁶	4.72 x 10 ⁶
LFSB 52	18600	LFKL 136-130	1500	177.2	130	136	157.2	52	4000	3	1500	2500	33	75	47	5.25 x 10 ⁶	15.9 x 10 ⁶
LFSB 52	18600	LFKL 186-145	2900	183.5	145	186	157.2	52	4000	4	2400	4500	51	105	126	5.25 x 10 ⁶	15.9 x 10 ⁶
LFSB 52	18600	LFKL 205-155	3900	183.5	155	205	157.2	52	4000	5	4800	8000	101	480	288	5.25 x 10 ⁶	15.9 x 10 ⁶

MOUNTING DIMENSIONS – Dimensions in mm																
PART NUMBER RAIL	WEIGHT g/m	PART NUMBER CARRIAGE	A ₁	A ₂	a ₁	a ₂	C ₁	C ₂	C ₃	H ₁	H ₂	H ₃	h ₅	K ₄	K ₅	
LFSB 32	1000	LFKL 112-86	59	54	63.5	26	7	60	70	32	20.3	14	101.6	M8	18	
LFSB 52	3000	LFKL 136-130	90	83	88.9	42	10	60	70	46.1	29	19.5	127	M10	30	
LFSB 52	3000	LFKL 186-145	105	90	88.9	42	10	105	110	53.8	35.3	24	127	M10	30	
LFSB 52	3000	LFKL 205-155	115	95	112	42	10	120	140	55	35.3	24	127	M12	34	

- Rail end support mounting holes can be provided to suit individual requirements.
- Enclosed carriages are provided with felt shaft wipers with provision for lubrication, and a running bottom sealing element.
- Contact factory for longer lengths.
- Not valid for corrosion resistant series.

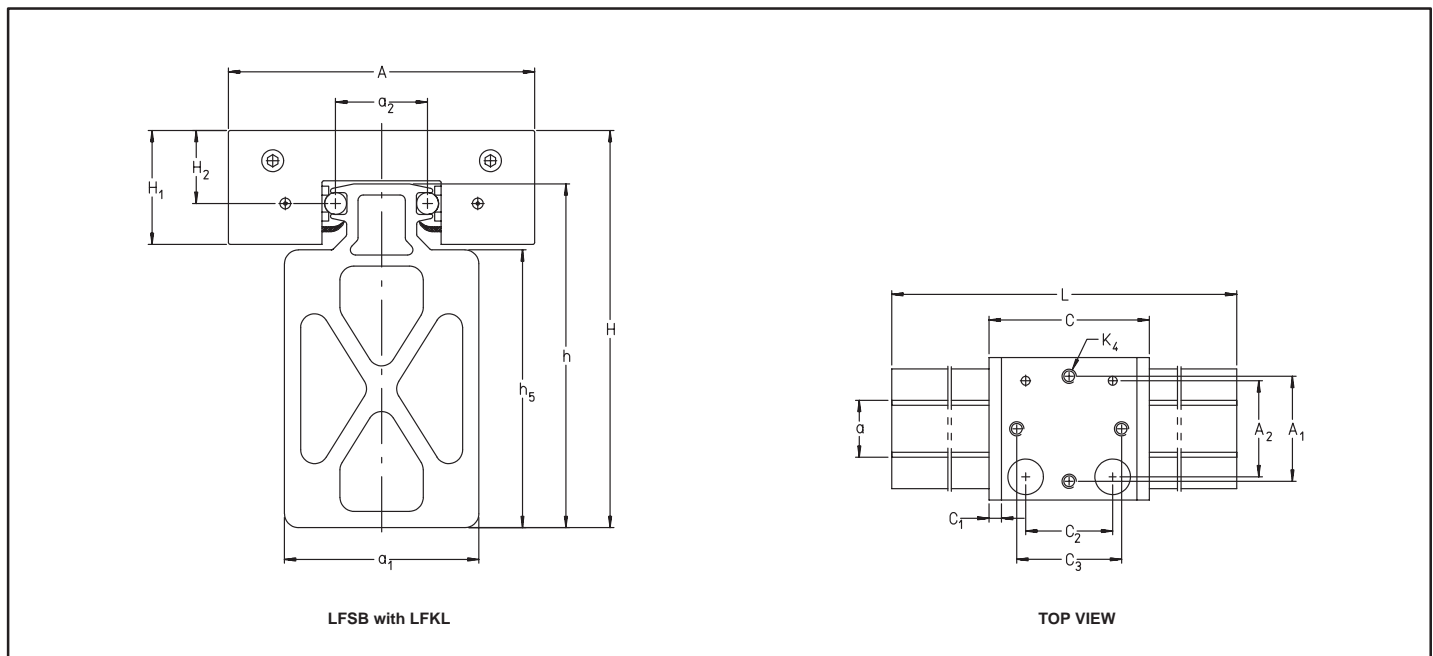

Linear Modular Unit With Track Roller Guidance System And Toothed Belt Drive MLF..ZR SERIES

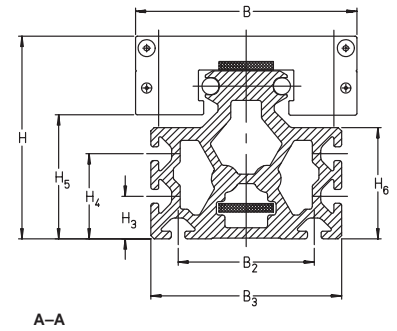

For details on part numbers, descriptive suffixes and various technical references, please refer to front of this section.

For engineering or technical information contact your local sales representative or call Distributor Sales (800)523-6572 or Linear Sales (800)462-3399.

DIMENSION TABLE - Dimensions in mm																					
PART NUMBER	DIMENSIONS																				
	L	B	H	L ₁ ±0.1	B ₁ ±0.1	O	H ₁	H ₂	B ₂	B ₃	H ₃	H ₄	H ₅	H ₆	L ₃	O ₁	D	D ₁ G7	D ₂	T ±0.1	
MLF 32 086 ZR	155	86	82	50	59	M8	40	81.5	43	75	25	-	50	47	80	M6	80	70	61	2.3	
MLF 52 130 ZR	200	130	119	55	90	M10	57.7	117.75	80	112	25	50	72.8	65.4	115.4	M8	115	95	76	3.5	
MLF 52 145 ZR	245	145	125	80	105	M10	57.7	117.75	80	112	25	50	71.2	65.4	115.4	M8	115	95	76	3.5	
MLF 52 155 ZR	260	155	125	90	115	M12	57.7	117.75	80	112	25	50	70	65.4	115.4	M8	115	95	76	3.5	

TOOTHED BELT / GEAR WHEELS					
	TOOTHED BELT TYPE	PERMISSIBLE TOOTHED BELT DRIVE FORCE N	MASS kg/m	DISPLACEMENT mm/rev.	MASS MOMENT OF INERTIA OF BOTH GEAR WHEELS kg·m ²
MLF 32 086 ZR	20 AT 5	640	0.068	175	2.2·10 ⁻⁴
MLF 52 130 ZR	32 AT 10	1750	0.2	270	12.6·10 ⁻⁴
MLF 52 145 ZR	32 AT 10	1750	0.2	270	12.6·10 ⁻⁴
MLF 52 155 ZR	32 AT 10	1750	0.2	270	12.6·10 ⁻⁴

- 1) When using standard brush wipers:
 $L_2 = \text{Stroke} + L + 2 \times S$
 The additional factor S represents a security which is dependent on the specific application and must be at least 85 mm;
 Stroke in mm
 When using bellows: $L_2 = \text{Stroke} \times 1.4 + L + 2 \times S$
 The factor of 1.4 accounts for the compressed length of the bellows.
 Maximum length of profiled support rail $L_2 = 6000$ mm (longer profiled support rails available on request)

2) Total weight $G_{\text{tot}} = G_0 + \frac{G_{100} \times (\text{Stroke} + 2 \times S)}{100}$ [kg]
 When using bellows:
 Total weight $G_{\text{tot}} = G_0 + \frac{G_{100} \times \text{Stroke} \times 1.4}{100}$ [kg]

- 3) G_0 = weight of unit for stroke length 0
 4) G_{100} = weight of unit per 100 mm stroke of the carriage
 5) G_{LFLKL} = weight of moving mass of the carriage
 6) Values for individual loads and with complete support for underside of the unit. These must be reduced for combined loading.

Mounting dimensions

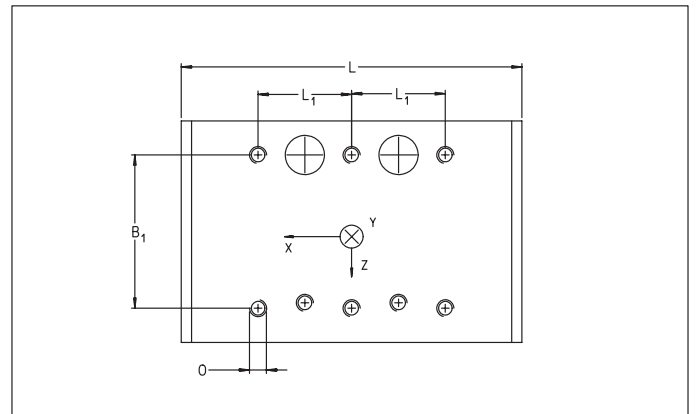

Carriage

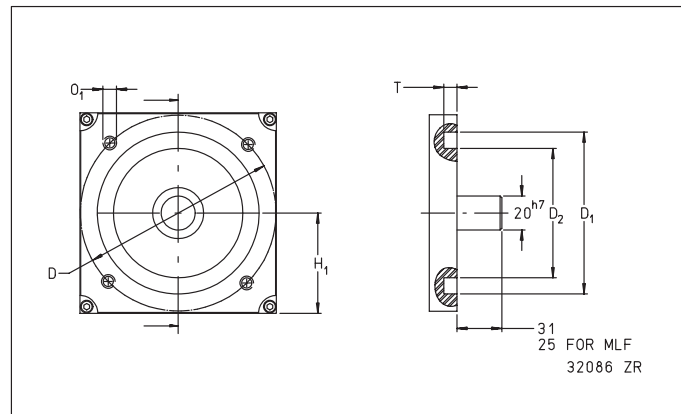

Coupling/Coupling Housing

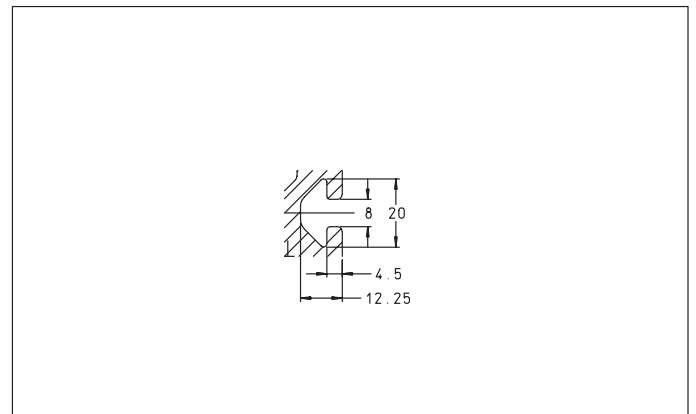

T-grooves



Linear Modular Unit With Track Roller Guidance System And Toothed Belt Drive MLF..ZR SERIES

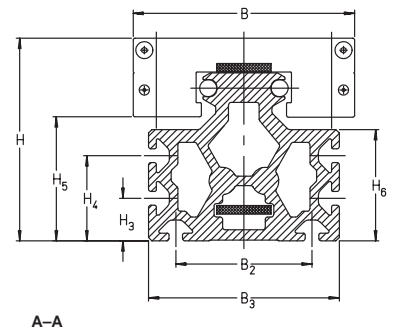

For details on part numbers, descriptive suffixes and various technical references, please refer to front of this section.

For engineering or technical information contact your local sales representative or call Distributor Sales (800)523-6572 or Linear Sales (800)462-3399.

MASS ²⁾			PERMISSIBLE LOADS ⁶⁾				PERMISSIBLE MOMENTS ⁶⁾						GEOMETRICAL MOMENTS OF INERTIA cm ⁴	
G ₀ ³⁾ kg	G ₁₀₀ ⁴⁾ kg	G _{LFLK} ⁵⁾ kg	F _{yperm} N	F _{oyperm} N	F _{zperm} N	F _{ozperm} N	M _{xperm} Nm	M _{oxperm} Nm	M _{yperm} Nm	M _{oyperm} Nm	M _{zperm} Nm	M _{ozperm} Nm	ly	lz
4.8	0.6	0.8	850	1400	1000	1000	11	18	30	30	26	43	100	76
12	1.28	2	1500	2500	3500	3500	33	52	105	105	47	78	392	304
13.9	1.28	3.2	2400	4000	4500	4500	51	84	236	236	126	210	392	304
15.7	1.28	5	4800	7900	8000	8000	101	166	480	480	288	474	392	304

MLF 52130 ZR AR

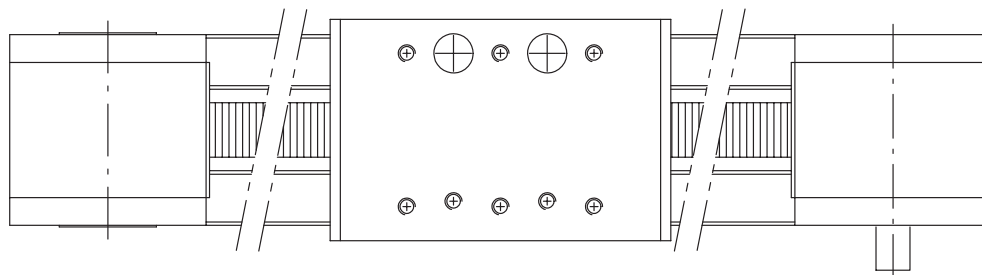
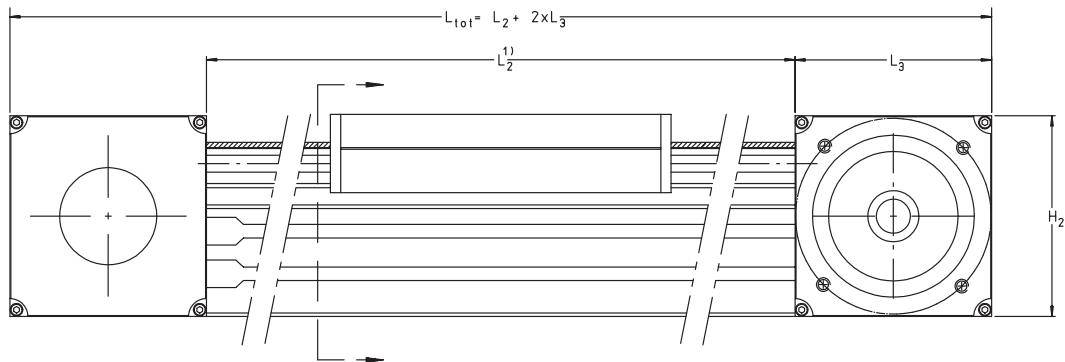

Linear Modular Unit With Recirculating Ball Bearing Guidance System And Toothed Belt Drive

MKUE..ZR..N SERIES

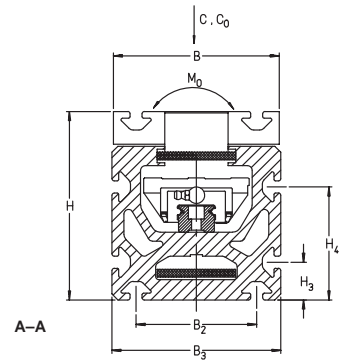

For details on part numbers, descriptive suffixes and various technical references, please refer to front of this section.

For engineering or technical information contact your local sales representative or call Distributor Sales (800)523-6572 or Linear Sales (800)462-3399.

DIMENSION TABLE - Dimensions in mm																
PART NUMBER	DIMENSIONS															
	L	B	H	B ₁ ±0.2	H ₁	H ₂	L ₁ ±0.1	H ₃	H ₄	B ₂	B ₃	O	D	D ₁ G7	D ₂	T ±0.1
MKUE 25 ZR..N	250	110	125	80	57.7	115.5	263	25	75	80	112	M8	115	95	76	3.5

TOOTHED BELT / GEAR WHEELS					
	TOOTHED BELT TYPE	PERMISSIBLE TOOTHED BELT DRIVE FORCE N	MASS kg/m	DISPLACEMENT mm/rev.	MASS MOMENT OF INERTIA OF BOTH GEAR WHEELS kg·m ²
MKUE 25 ZR..N	50 AT 10	1880	0.315	250	30.6·10 ⁻⁴

1) $L_2 = \text{Stroke} + L_1 + 2 \times S$
 The additional factor S represents a security which is dependent on the specific application and must be at least 85 mm;
 Stroke in mm
 Maximum length of profiled support rail $L_2 = 4000$ mm (longer profiled support rails available on request)

2) Total weight $G_{tot} = G_0 + \frac{G_{100} \times (\text{Stroke} + 2 \times S)}{100}$ [kg]

3) G_0 = weight of unit for stroke length 0

4) G_{100} = weight of unit per 100 mm stroke of the carriage

5) G_{MKWE} = weight of moving mass of the carriage

6) Values with complete support for underside of the unit

Mounting dimensions

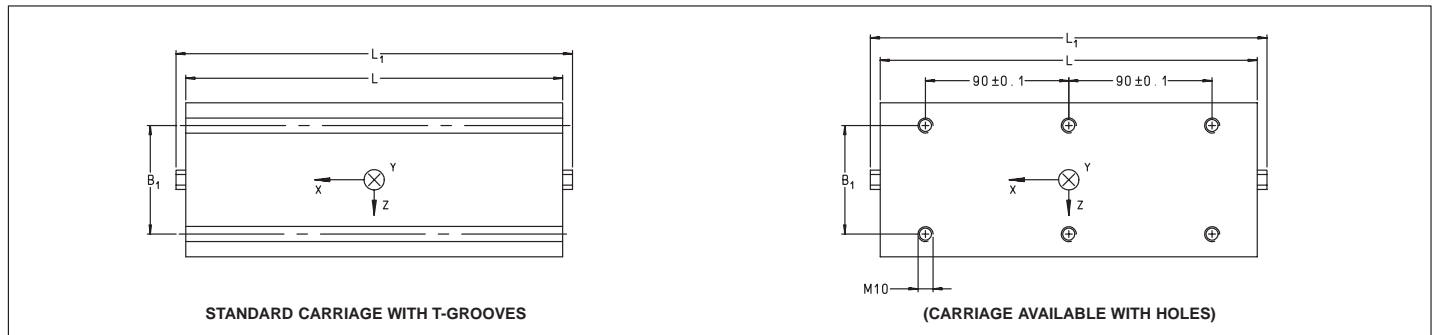

Carriage

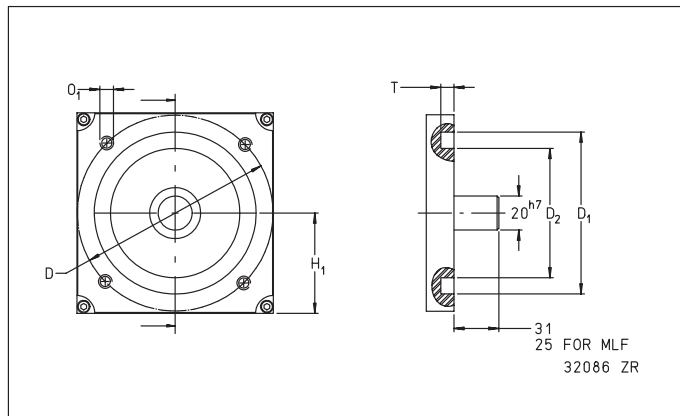

Coupling/Coupling Housing

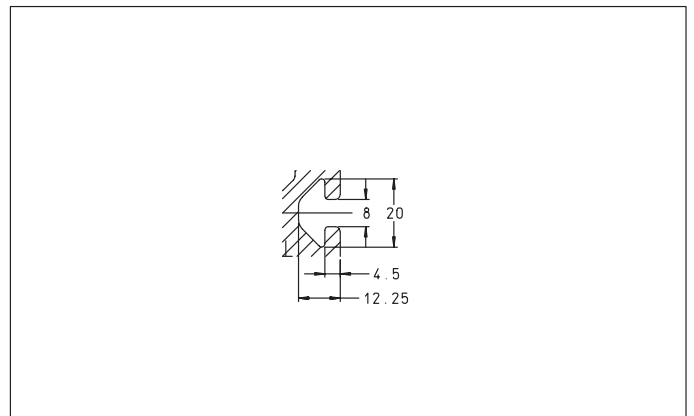

T-grooves



Linear Modular Unit With Recirculating Ball Bearing Guidance System And Toothed Belt Drive MKUE..ZR..N SERIES

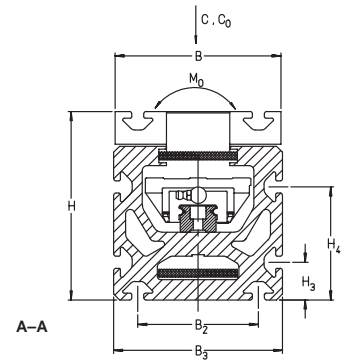

For details on part numbers, descriptive suffixes and various technical references, please refer to front of this section.

For engineering or technical information contact your local sales representative or call Distributor Sales (800)523-6572 or Linear Sales (800)462-3399.

MASS ²⁾			BASIC LOAD RATINGS ⁶⁾		PERMISSIBLE STATIC MOMENT ⁶⁾	GEOMETRICAL MOMENTS OF INERTIA cm ⁴	
G ₀ ³⁾ kg	G ₁₀₀ ⁴⁾ kg	G _{MKWE} ⁵⁾ kg	C kN	C ₀ kN	M ₀ STATIC Nm	l _y	l _z
16.2	1.66	3,8	26.3	41.8	411	733	517

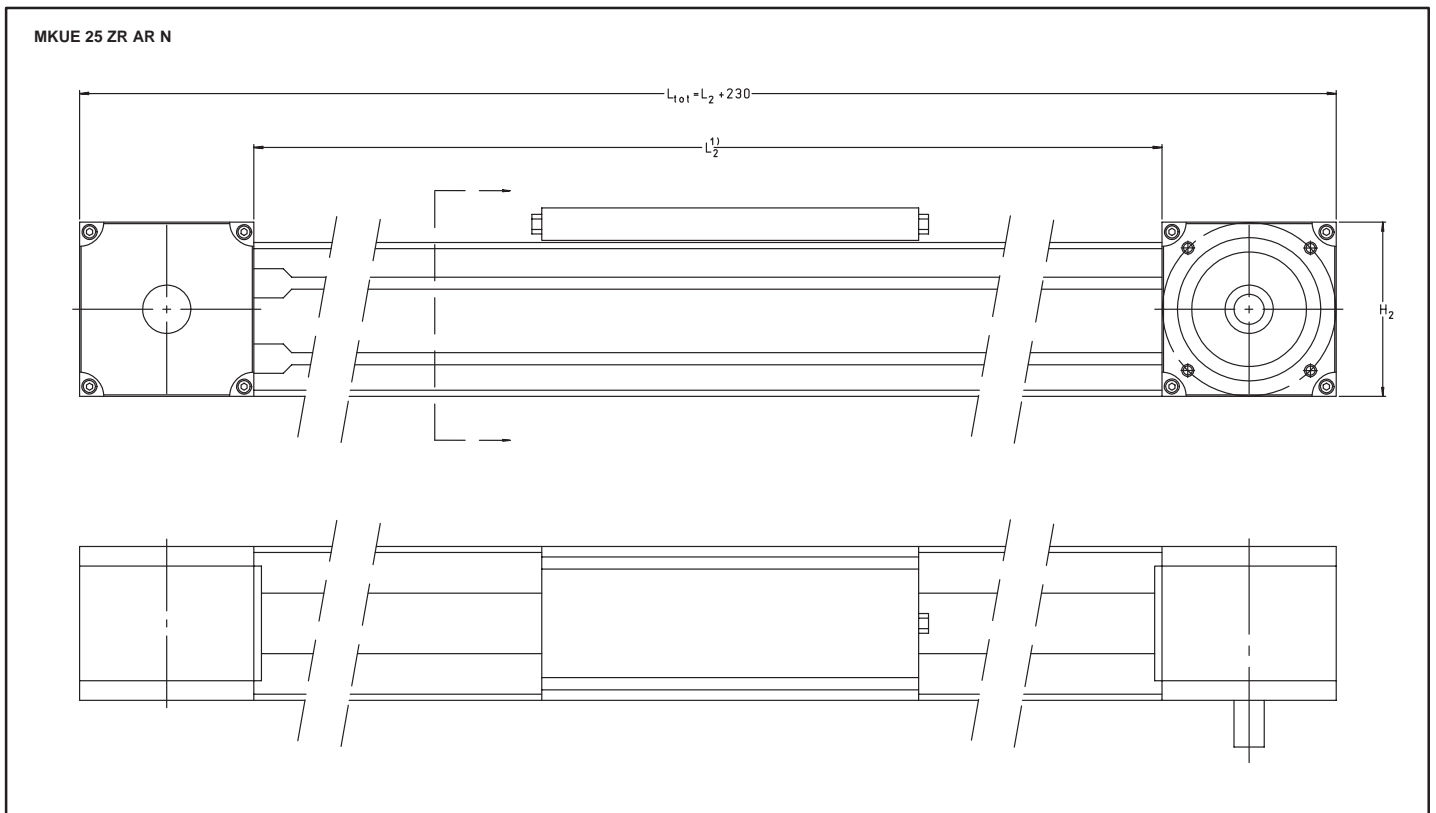

Linear Modular Unit With Recirculating Ball Bearing Guidance System And Ball Screw Drive

MKUE..KGT SERIES

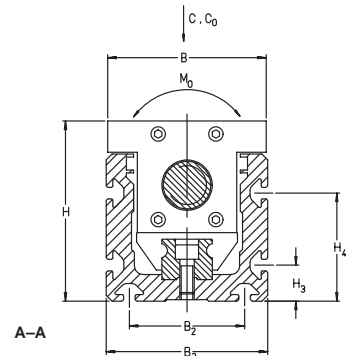

For details on part numbers, descriptive suffixes and various technical references, please refer to front of this section.

For engineering or technical information contact your local sales representative or call Distributor Sales (800)523-6572 or Linear Sales (800)462-3399.

DIMENSION TABLE - Dimensions in mm																
PART NUMBER	SPINDLE $d_0 \times P^7)$	DIMENSIONS														
		L	B	H	L_1 ± 0.1	B_1 ± 0.1	O	d $\varnothing h6$	H_1	H_2	L_3	L_4	H_3	H_4	B_2	
MKUE 25 KGT 5	32X5	200	110	125	55	80	M10	19	80	124.5	39	67	25	75	80	
MKUE 25 KGT 10	32X10	200	110	125	55	80	M10	19	80	124.5	39	67	25	75	80	
MKUE 25 KGT 40	32X40	200	110	125	55	80	M10	19	80	124.5	39	67	25	75	80	

1) $L_2 = \text{Stroke} \times 1.2 + L + 2 \times S$
 $S = \text{spindle lead } P; \text{stroke in mm}$
 Maximum length of profiled Support rail $L_2 = 4000$ mm (longer profiled support rails available on request).
 Modular units with a stroke length over 1200 mm can be fitted with movable spindle supports.

2) Total weight $G_{\text{tot}} = G_0 + \frac{G_{100} \times \text{Stroke} \times 1.2}{100}$ [kg]

- 3) G_0 = weight of unit for stroke length 0
- 4) G_{100} = weight of unit per 100 mm stroke of the carriage
- 5) G_{MKWE} = weight of moving mass of the carriage
- 6) Values with complete support for underside of the unit
- 7) $d_0 \times P$ = nominal spindle diameter \times spindle lead

Mounting dimensions

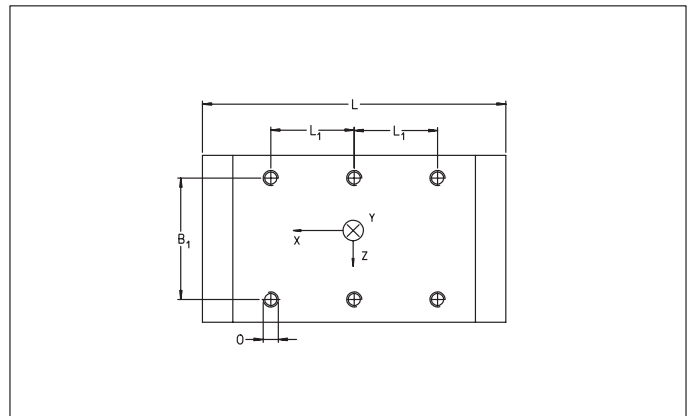

Carriage

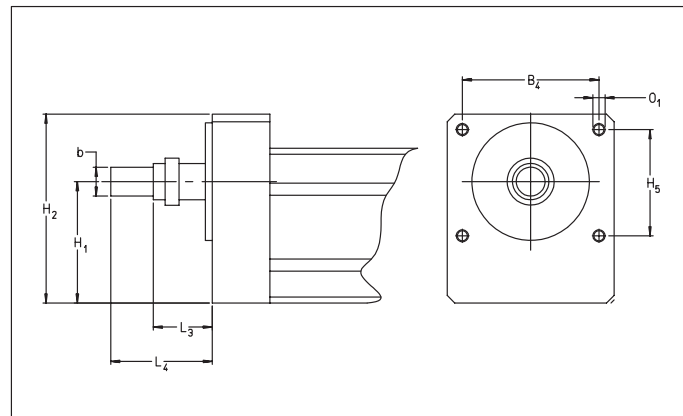

Coupling/Coupling Housing

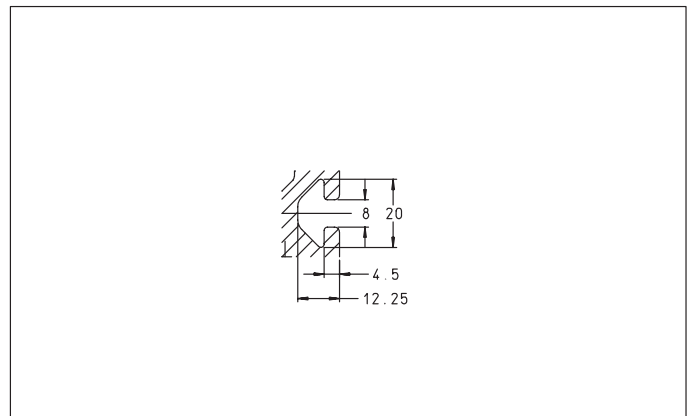

T-grooves



Linear Modular Unit With Recirculating Ball Bearing Guidance System And Ball Screw Drive MKUE..KGT SERIES

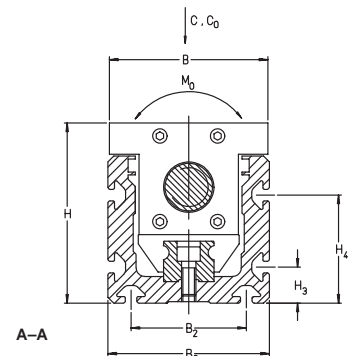

For details on part numbers, descriptive suffixes and various technical references, please refer to front of this section.

For engineering or technical information contact your local sales representative or call Distributor Sales (800)523-6572 or Linear Sales (800)462-3399.

				MASS ²⁾			BASIC LOAD RATINGS ⁶⁾		PERMISSIBLE STATIC MOMENT ⁶⁾	GEOMETRICAL MOMENTS OF INERTIA cm ⁴	
B ₃	H ₅	B ₄	O ₁	G ₀ ³⁾ kg	G ₁₀₀ ⁴⁾ kg	G _{MKWE} ⁵⁾ kg	C kN	C ₀ kN	M ₀ STATIC Nm	ly	lz
112	70	90	M8	17.4	2	4.3	26.3	41.8	411	717	408
112	70	90	M8	17.4	2	4.3	26.3	41.8	411	717	408
112	70	90	M8	17.4	2	4.3	26.3	41.8	411	717	408

MKUE 25 KGT 10

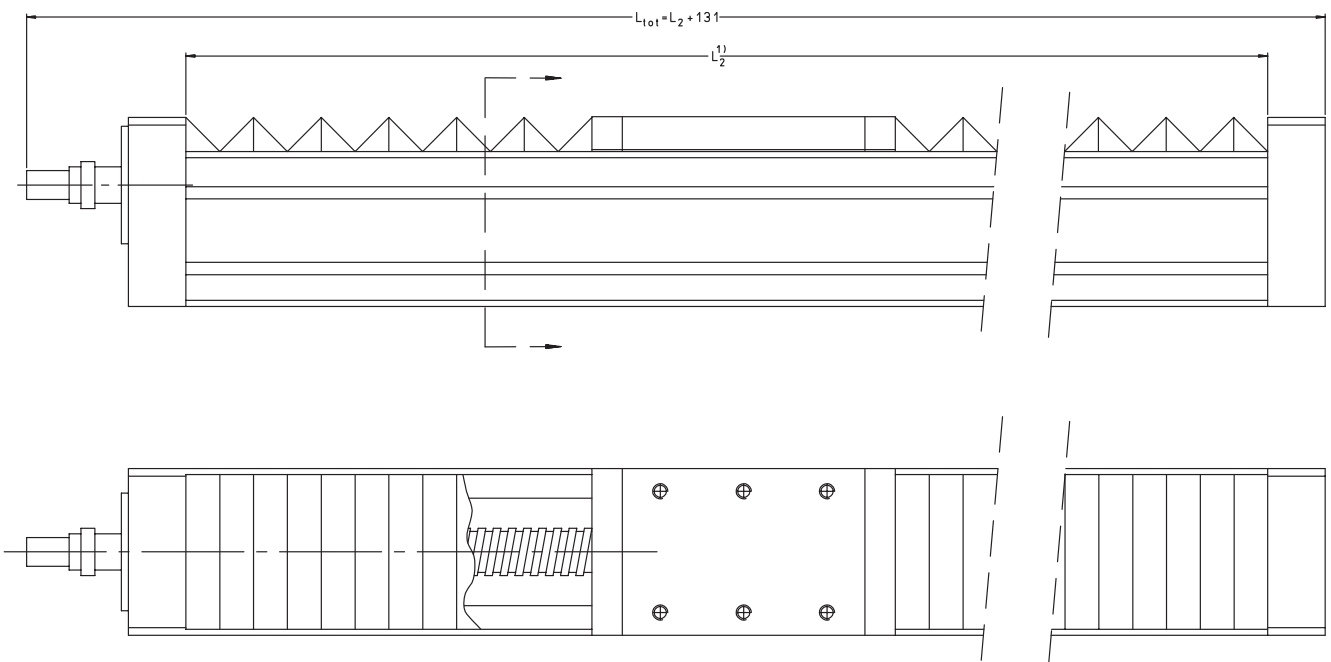

Linear Roller Bearings

RUS, RUS..KS SERIES

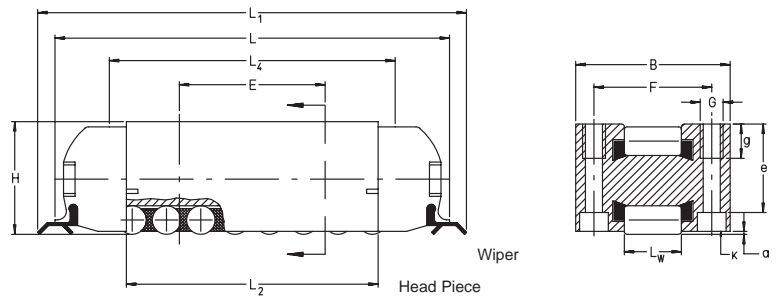

RUS 19 069 to RUS 38 206

For details on part numbers, descriptive suffixes and various technical references, please refer to front of this section.

For engineering or technical information contact your local sales representative or call Distributor Sales (800)523-6572 or Linear Sales (800)462-3399.

DIMENSION TABLE - Dimensions in mm										
PART NUMBER		MASS kg	DIMENSIONS							
			H	L	B	L ₁	L ₂	L ₃	L _w	a
RUS 19 069		0.16	19	69	27	75	44	—	10	0.2
	RUS 19 069 KS	0.19	19	—	27	—	44	76	10	0.2
RUS 19 105		0.27	19	105	27	111	78.5	—	10	0.2
	RUS 19 105 KS	0.29	19	—	27	—	78.5	112	10	0.2
RUS 26 086		0.41	26	86	40	92	53	—	14	0.2
	RUS 26 086 KS	0.49	26	—	40	—	53	92	14	0.2
RUS 26 102		0.53	26	102	40	108	69	—	14	0.2
	RUS 26 102 KS	0.61	26	—	40	—	69	108	14	0.2
RUS 26 126		0.70	26	126	40	132	93	—	14	0.2
	RUS 26 126 KS	0.78	26	—	40	—	93	132	14	0.2
RUS 38 134		1.27	38	133	52	133	85	—	20	0.2
	RUS 38 134 KS	1.53	38	—	52	—	85	136	20	0.2
RUS 38 206		2.28	38	206	52	206	158	—	20	0.2
	RUS 38 206 KS	2.53	38	—	52	—	158	209	20	0.2
RUS 65 210		7.5	65	211	76	234	134	—	30	0.5
RUS 85 280*)		16	85	281	104	303	185	—	40	0.5

- 1) If the lubricating nipple is replaced by tube or pipe connections, the thread length must not exceed 6 mm.
 - 2) Minimum length to be supported
 - 3) UG guideway for RUS 85 280 available on request
- *) Available on request

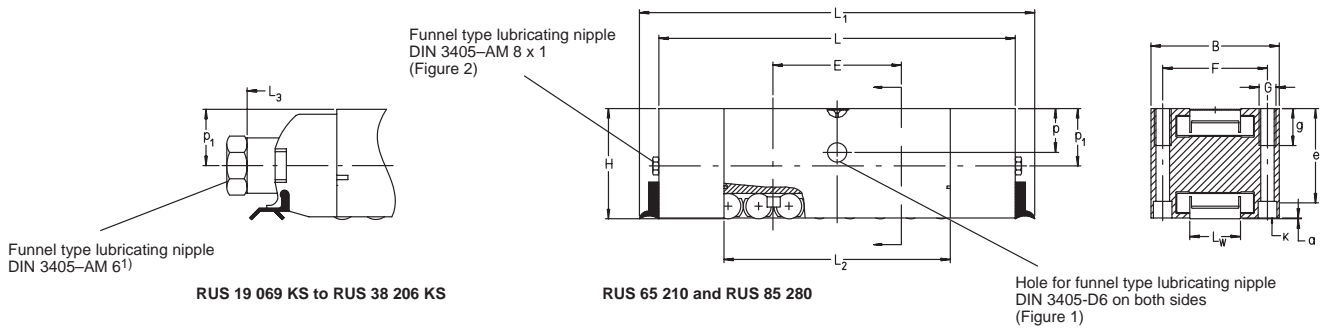

BASIC LOAD RATINGS		MOUNTING DIMENSIONS								K FOR FIXING SCREWS TO DIN 912	MATCHING ADJUSTING GIBS	MATCHING GUIDEWAYS
dyn. C N	stat. C ₀ N	L ₄ ²⁾	E ±0.1	F ±0.1	G	e	g	p	p ₁			
42,000	33,000	50	25.5	20.6	M4	15.5	6	-	-	M3	VUS 19 069	UG 6628 UV 5323 UFA 3210 UFK 3210 UFB 4710
42,000	33,000	50	25.5	20.6	M4	15.5	6	-	10	M3	VUS 19 069	
68,000	61,000	85	50	20.6	M4	15.5	6	-	-	M3	VUS 19 105	
68,000	61,000	85	50	20.6	M4	15.5	6	-	10	M3	VUS 19 105	
76,000	56,000	63	28	30	M6	21	10	-	-	M4	VUS 26 086	UG 9741 UV 7532 UFA 4710 UFK 4710 UFB 6412
76,000	56,000	63	28	30	M6	21	10	-	13.5	M4	VUS 26 086	
95,000	75,000	79	44	30	M6	21	10	-	-	M4	VUS 26 102	
95,000	75,000	79	44	30	M6	21	10	-	13.5	M4	VUS 26 102	
122,000	103,000	103	68	30	M6	21	10	-	-	M4	VUS 26 126	
122,000	103,000	103	68	30	M6	21	10	-	13.5	M4	VUS 26 126	
179,000	133,000	100	51	41	M8	31	14	-	-	M6	VUS 38 134	UG 12 553 UV 9542 UFA 6412 UFK 6412 UFB 7812
179,000	133,000	100	51	41	M8	31	14	-	19.5	M6	VUS 38 134	
305,000	265,000	172	102	41	M8	31	14	-	-	M6	VUS 38 206	
305,000	265,000	172	102	41	M8	31	14	-	19.5	M6	VUS 38 206	
465,000	345,000	-	76	62	M10	55	22	26	34	M8	VUS 65 210	UG 16 260 UV 13 863 UFA 8815 UFK 8815 UFB 10 615
840,000	620,000	-	101.5	82.5	M14	73	30	33	45	M10	VUS 85 280	UG... ³⁾ UV 16 977 UFA 11 518 UFK 11 518 UFB 14 0185

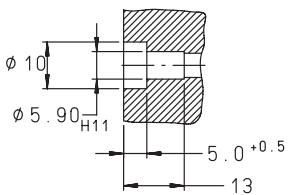

Figure 1

Lubrication holes are provided on both sides for funnel type grease nipples DIN 3405-D6 (supplied with the bearing) or either tube or pipe connection. If no lubrication connection is to be provided the holes should be plugged with the lubricating nipples.

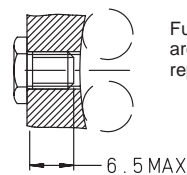
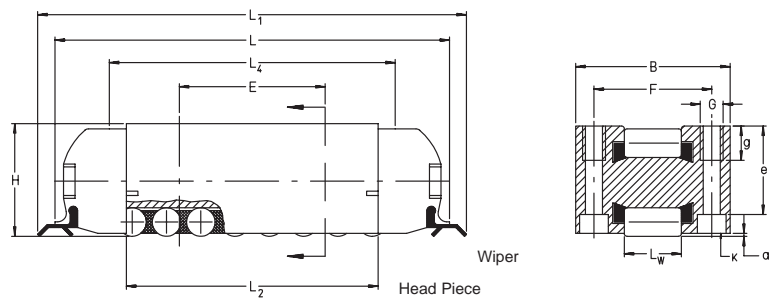

Figure 2

Funnel type lubricating nipples DIN 3405-AM 8x1 are mounted in the head pieces. They can be replaced by tube or pipe connections.

Linear Roller Bearings

RUSZ, RUSZ..KS SERIES



RUS 19 069 to RUS 38 206

For details on part numbers, descriptive suffixes and various technical references, please refer to front of this section.

For engineering or technical information contact your local sales representative or call Distributor Sales (800)523-6572 or Linear Sales (800)462-3399.

DIMENSION TABLE - Dimensions in mm

PART NUMBER	DIMENSIONS							
	H	L	B	L ₁	L ₂	L ₃	L _w	a
RUSZ 12044	19.05	69	25.4	75	44	—	10	0.2
RUSZ 18059	28.57	94	38.1	100	60	—	14	0.2
RUSZ 24084	38.1	133	50.8	133	85	—	20	0.2
RUSZ 12044 KS	19.05	69	25.4	75	44	76	10	0.2
RUSZ 18059 KS	28.57	94	38.1	100	60	132	14	0.2
RUSZ 24084 KS	38.1	133	50.8	133	85	136	20	0.2

- 1) If the lubricating nipple is replaced by tube or pipe connections, the thread length must not exceed 6 mm.
- 2) Minimum length to be supported



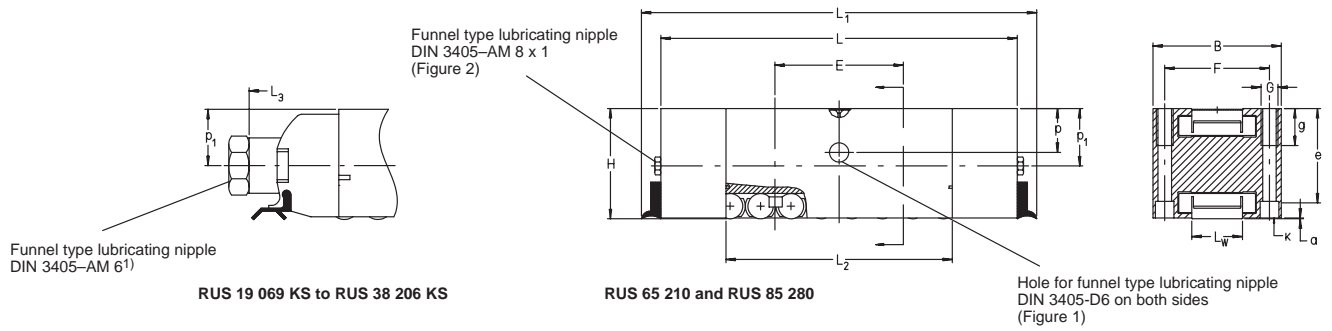

BASIC LOAD RATINGS		MOUNTING DIMENSIONS								K FOR FIXING SCREWS TO DIN 912	MATCHING ADJUSTING GIBS	MATCHING GUIDEWAYS
dyn. C N	stat. C ₀ N	L ₄ ²⁾	E ±0.1	F ±0.1	G	e	g	p	p ₁			
42000	33000	50	25.5	20.6	-	15.5	-	-	-	M3x22	VUSZ 12044	UG6628 UV5323 UFA/UFK3210 UFB4710
86000	65000	71	38	31	-	23.6	-	-	-	M4x30	VUSZ 18059	UG9745 UV7532 UFA/UFK4710 UFB6412
179000	133000	100	51	41	-	32.1	-	-	-	M5x45	VUSZ 24084	UG12553 UV9542 UFA/UFK6412 UFB7812
42000	33000	50	25.5	20.6	-	15.5	-	-	-	M3x22	VUSZ 12044	UG6628 UV5323 UFA/UFK3210 UFB4710
86000	65000	71	38	31	-	23.6	-	-	-	M4x30	VUSZ 18059	UG9745 UV7532 UFA/UFK4710 UFB6412
179000	133000	100	51	41	-	32.1	-	-	-	M5x45	VUSZ 24084	UG12553 UV9542 UFA/UFK6412 UFB7812

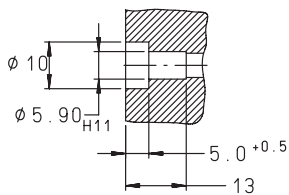

Figure 1

Lubrication holes are provided on both sides for funnel type grease nipples DIN 3405-D6 (supplied with the bearing) or either tube or pipe connection. If no lubrication connection is to be provided the holes should be plugged with the lubricating nipples.

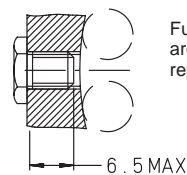
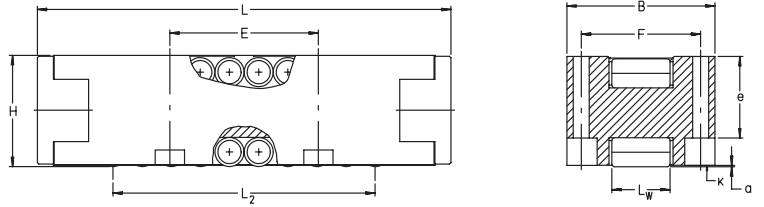

Figure 2

Funnel type lubricating nipples DIN 3405-AM 8x1 are mounted in the head pieces. They can be replaced by tube or pipe connections.

Linear Roller Bearings

PR SERIES



For details on part numbers, descriptive suffixes and various technical references, please refer to front of this section.

For engineering or technical information contact your local sales representative or call Distributor Sales (800)523-6572 or Linear Sales (800)462-3399.

DIMENSION TABLE - Dimensions in mm

PART NUMBER	MASS kg	DIMENSIONS					
		H	L	B	L ₂	L _w	a
PR 14 032	0.095	14.285	51	22.23	31	9	0.2
PR 14 044	0.2	19.05	69	25.4	42	10	0.35
PR 14 061	0.65	28.57	96	38.1	58.5	16	0.35
PR 14 089	1.75	38.1	142	50.8	90	20	0.4
PR 14 135	5.65	57.15	196	76.2	126	30	0.5
PR 14 182	13.25	76.2	264	101.6	167	40	0.6

- 1) UG guideway for PR 14 182 available on request
- 2) Not available from stock. Please check delivery time.

Ordering examples:

Linear roller bearing PR 14 061
with a tolerance for the nominal height H of -10 to -15 μm:
PR 14 061 -10 -15

Linear roller bearing PR 14 135
with a tolerance for the nominal height H of -10 to -20 μm:
PR 14 135 -10 -20

Linear Roller Bearings

PR SERIES

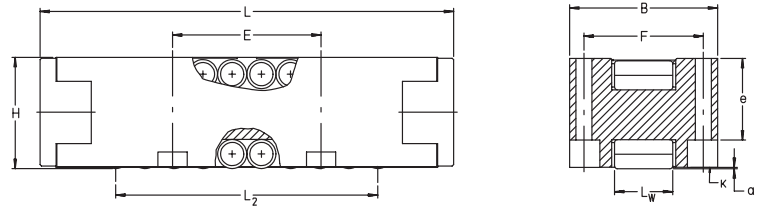

For details on part numbers, descriptive suffixes and various technical references, please refer to front of this section.

For engineering or technical information contact your local sales representative or call Distributor Sales (800)523-6572 or Linear Sales (800)462-3399.

BASIC LOAD RATINGS		MOUNTING DIMENSIONS			K FOR FIXING SCREWS TO DIN 912	MATCHING ADJUSTING GIBS	MATCHING GUIDEWAYS	
dyn. C N	stat. C ₀ N	E ±0.1	F ±0.1	e				
21,700	17,600	19	17.1	10	M2.5	–	UG 6628 UV 5323	UFA 3210 UFK 3210
44,000	37,500	25.5	20.6	14	M3	VUSZ 12 044	UG 6628 UV 5323	UFA 3210 UFK 3210 UFB 4710
107,000	86,000	38	31	20.8	M4	VUSZ 18 059	UG 9741 UV 7532	UFA 4710 UFK 4710 UFB 6412
205,000	171,000	51	41	28	M5	VUSZ 24 084	UG 12 553 UV 9542	UFA 6412 UFK 6412 UFB 7812
435,000	345,000	76.2	62	42	M6	VUSZ 36 135 ²⁾	UG 16 260 UV 13 863	UFA 8815 UFK 8815 UFB 10 615
790,000	620,000	101.6	82.5	56	M8	VUSZ 48 182 ²⁾	UG.... ¹⁾ UV 16 977	UFA 11 518 UFK 11 518 UFB 14 018

Adjusting Gibs

VUS, METRIC SIZES SERIES

VUSZ, INCH SIZES SERIES

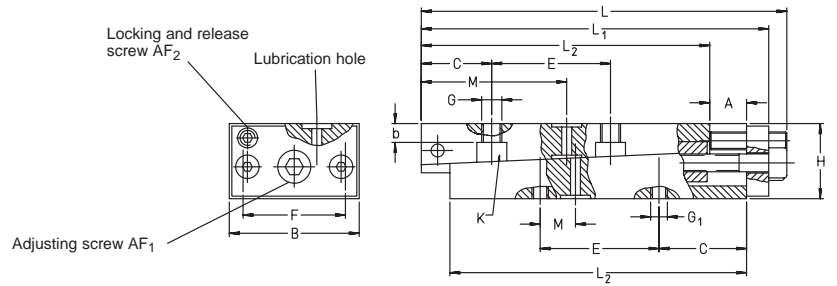

For details on part numbers, descriptive suffixes and various technical references, please refer to front of this section.

For engineering or technical information contact your local sales representative or call Distributor Sales (800)523-6572 or Linear Sales (800)462-3399.

DIMENSION TABLE - Dimensions in mm										
PART NUMBER	MASS kg	DIMENSIONS			MOUNTING DIMENSIONS					
		B	H min.	L max.	L ₁ max.	L ₂	E ± 0.1	F ± 0.1	b	C
VUS 19 069	0.24	26.5	16	78	73	62	25.5	20.6	4	16.5
VUS 19 105	0.32	26.5	16	123	119	100	50	20.6	3.5	25
VUS 26 086	0.6	39.5	25	97	89	75	28	30	6	20.5
VUS 26 102	0.71	39.5	25	113	105	91	44	30	6	20.5
VUS 26 126	0.9	39.5	25	137	129	115	68	30	6	20.5
VUS 38 134	1.47	51.5	30	141	131	115	51	41	7	28
VUS 38 206	2.1	51.5	25	250	240	200	102	41	5	49

DIMENSION TABLE - Dimensions in mm										
PART NUMBER	MASS kg	DIMENSIONS			MOUNTING DIMENSIONS					
		B	H min.	L max.	L ₁ max.	L ₂	E ± 0.1	F ± 0.1	b	C
VUSZ 12 044	0.19	25	16	78	73	62	25.5	19 ¹⁾	4	16.5
VUSZ 18 059	0.63	37.6	25	107	99	85	38	31	6	20.5
VUSZ 24 084	1.38	50	30	141	131	115	51	41	7	28

1) Distance between the mounting holes in the top wedge of the gib; deviates from the bottom wedge

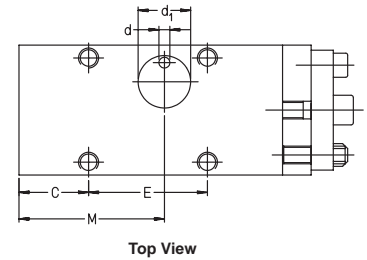

DIMENSION TABLE - Dimensions in mm										
M	d	d ₁	A max.	G	G ₁ , K FOR FIXING SCREW TO DIN 912	HEIGHT CHANGE		ADJUSTING SCREW AF ₁	LOCKING AND RELEASE SCREW AF ₂	MATCHING LINEAR ROLLER BEARINGS
						ΔH max.	PER SCREW ROTATION			
16.5	3.5	12	7	M 4	M 3	0.35	0.035	3	2	RUS 19 069
29	3.5	12	15	M 4	M 3	0.5	0.023	3	2.5	RUS 19 105
19.5	5	16	8	M 6	M 4	0.4	0.05	6	3	RUS 26 086
27.5	5	16	8	M 6	M 4	0.4	0.05	6	3	RUS 26 102
39.5	5	16	8	M 6	M 4	0.4	0.05	6	3	RUS 26 126
30.5	5	22	8	M 8	M 6	0.4	0.062	8	4	RUS 38 134
61	5	22	30	-	M 6	1	0.05	8	5	RUS 38 206

DIMENSION TABLE - Dimensions in mm										
M	d	d ₁	A max.	G	G ₁ , K FOR FIXING SCREW TO DIN 912	HEIGHT CHANGE		ADJUSTING SCREW AF ₁	LOCKING AND RELEASE SCREW AF ₂	MATCHING LINEAR ROLLER BEARINGS
						ΔH max.	PER SCREW ROTATION			
16.5	3.5	12	7	-	M 3	0.35	0.035	3	2	PR 14 044
20	5	16	8	-	M 4	0.4	0.05	6	3	PR 14 061
30.5	5	22	8	-	M 5	0.4	0.062	8	4	PR 14 089

Linear Roller Bearings With Integral Adjusting Gib RUSV..KS SERIES

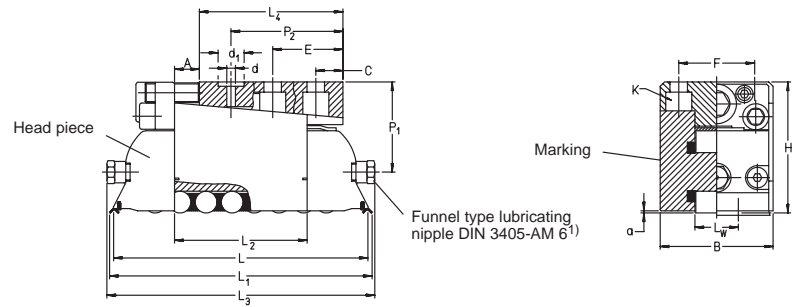

For details on part numbers, descriptive suffixes and various technical references, please refer to front of this section.

For engineering or technical information contact your local sales representative or call Distributor Sales (800)523-6572 or Linear Sales (800)462-3399.

DIMENSION TABLE - Dimensions in mm

PART NUMBER	MASS kg	DIMENSIONS										BASIC LOAD RATINGS	
		H	L	B	L _w	a	L ₁ ≈	L ₂	L ₃	L ₄	d ₁	dyn. C N	stat. C ₀ N
RUSV 30 069 KS	0.32	30	69	27	10	0.3	75	43.5	82	45	12	42,000	33,000
RUSV 30 105 KS	0.46	30	105	27	10	0.3	111	78.5	117	79	12	68,000	61,000
RUSV 42 086 KS	0.81	42	86	40	14	0.3	92	52.4	98	54	16	76,000	56,000
RUSV 42 102 KS	0.99	42	102	40	14	0.3	108	68.4	114	70	16	95,000	75,000
RUSV 42 126 KS	1.26	42	126	40	14	0.3	132	92.4	138	94	16	122,000	103,000
RUSV 60 134 KS	2.25	60	134	52	20	0.3	133	85	143	86	22	179,000	133,000
RUSV 60 206 KS	3.47	60	206	52	20	0.3	206	158	216	159	22	305,000	265,000

1) If the lubricating nipple is replaced by tube or pipe connections, the thread length must not exceed 6mm.

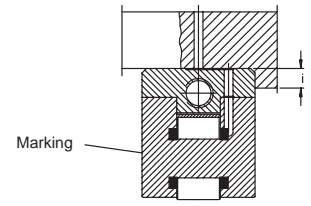
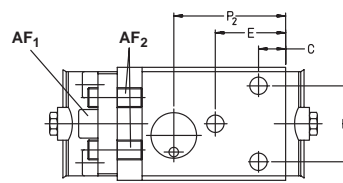

TOP VIEW

DIMENSION TABLE - Dimensions in mm															
MOUNTING DIMENSIONS									ADJUSTING SCREW AF ₁	LOCKING AND RELEASE SCREW AF ₂	HEIGHT CHANGE			MATCHING LINEAR ROLLER BEARINGS	MATCHING GUIDEWAY
C	E	F	i	P ₁	P ₂	P ₃	d	K			A	ΔH	PER SCREW ROTATION		
											max.	max.			
5	25	19	4	21	33	9	2.5	M 4	3	2	7	0.37	0.035	RUS 19 069 KS	UG 6628
5	45	19	4	21	53	9	2.5	M 4	3	2	7	0.37	0.023	RUS 19 105 KS	UV 5323 UFA 3210 UFK 3210 UFB 4710
8	23	26	6	29.5	38	14.5	3	M 6	6	3	10	0.52	0.05	RUS 26 086 KS	UG 9741
8	38	26	6	29.5	53	14.5	3	M 6	6	3	10	0.52	0.05	RUS 26 102 KS	UV 7532
8	58	26	6	29.5	73	14.5	3	M 6	6	3	10	0.52	0.05	RUS 26 126 KS	UFA 4710 UFK 4710 UFB 6412
10	45	35	8	41.5	65	18	4	M 8	8	4	15	0.78	0.062	RUS 38 134 KS	UG 12 553
10	115	35	8	41.5	145	18	4	M 8	8	4	15	0.78	0.05	RUS 38 206 KS	UV 9542 UFA 6412 UFK 6412 UFB 7812

Planetary Roller Screw

RGT SERIES

- Split roller nut, preloaded
- Standard ends configuration

For details on part numbers, descriptive suffixes and various technical references, please refer to front of this section.

For engineering or technical information contact your local sales representative or call Distributor Sales (800)523-6572 or Linear Sales (800)462-3399.

DIMENSION TABLE - Dimensions in mm															
NOMINAL DIAMETER d_0	PART NUMBER d_0	PITCH P	STROKE H	MASS kg	DIMENSIONS - SCREW SHAFT										
					d_1 ISO h6	d_2	d_3 -0.005	d_4	d_5 ISO h6	l_0	l_1	l_2	l_3	l_4	l_5
5	RGT 5.	1.	25	0.084	5	M6X0.5	6	10	4	113	11	22	34	75	14
	RGT 5.	1.	50	0.088	5	M6X0.5	6	10	4	138	11	22	34	100	14
	RGT 5.	1.	75	0.092	5	M6X0.5	6	10	4	163	11	22	34	125	14
	RGT 5.	1.	100	0.096	5	M6X0.5	6	10	4	188	11	22	34	150	14
8	RGT 8.	1.	25	0.11	5	M6X0.5	6	10	6	120	11	22	34	82	16
	RGT 8.	1.	50	0.121	5	M6X0.5	6	10	6	145	11	22	34	107	16
	RGT 8.	1.	100	0.141	5	M6X0.5	6	10	6	195	11	22	34	157	16
	RGT 8.	1.	150	0.16	5	M6X0.5	6	10	6	245	11	22	34	207	16
	RGT 8.	1.	200	0.18	5	M6X0.5	6	10	6	295	11	22	34	257	16
	RGT 8.	2.	25	0.11	5	M6X0.5	6	10	6	120	11	22	34	82	16
	RGT 8.	2.	50	0.121	5	M6X0.5	6	10	6	145	11	22	34	107	16
	RGT 8.	2.	100	0.141	5	M6X0.5	6	10	6	195	11	22	34	157	16
	RGT 8.	2.	150	0.16	5	M6X0.5	6	10	6	245	11	22	34	207	16
	RGT 8.	2.	200	0.18	5	M6X0.5	6	10	6	295	11	22	34	257	16
	RGT 8.	4.	25	0.11	5	M6X0.5	6	10	6	120	11	22	34	82	16
	RGT 8.	4.	50	0.121	5	M6X0.5	6	10	6	145	11	22	34	107	16
	RGT 8.	4.	100	0.141	5	M6X0.5	6	10	6	195	11	22	34	157	16
	RGT 8.	4.	150	0.16	5	M6X0.5	6	10	6	245	11	22	34	207	16
	RGT 8.	4.	200	0.18	5	M6X0.5	6	10	6	295	11	22	34	257	16
	RGT 8.	5.	25	0.11	5	M6X0.5	6	10	6	120	11	22	34	82	16
	RGT 8.	5.	50	0.121	5	M6X0.5	6	10	6	145	11	22	34	107	16
	RGT 8.	5.	100	0.141	5	M6X0.5	6	10	6	195	11	22	34	157	16
	RGT 8.	5.	150	0.16	5	M6X0.5	6	10	6	245	11	22	34	207	16
	RGT 8.	5.	200	0.18	5	M6X0.5	6	10	6	295	11	22	34	257	16

1) Limiting speed of the planetary roller screw. Critical speed n_{max} and limiting speed of the rolling bearings should be considered.



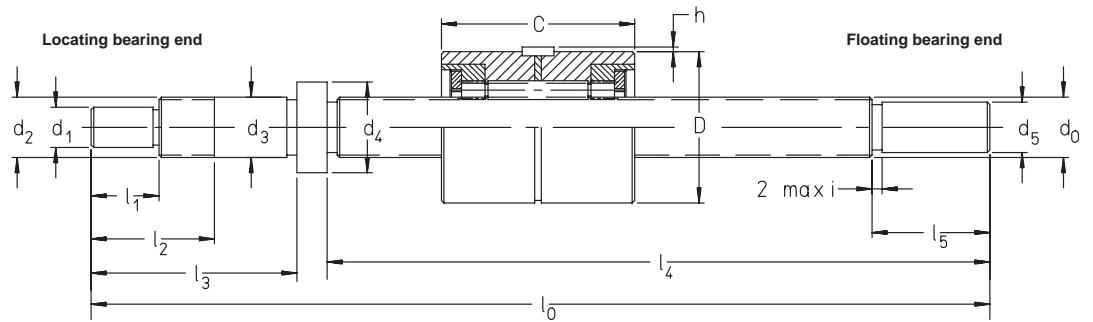

NUT			KEY TO DIN 6885	LOAD RATINGS		SPRINGS RATIO	LIMITING SPEED ¹⁾	LOCATING BEARING	FLOATING BEARING	SEAL	LOCK NUT
D ISO g6	h	C h12		dyn. C N	stat. C ₀ N	C _K N ^{2/3} / μm	n _g grease rpm				
19	1.3	31	3X3X10	5,300	5,400	27	6,000	ZKLN0624.2RS	HK0408TN	G4X8X2	ZM06
19	1.3	31	3X3X10	5,300	5,400	27	6,000	ZKLN0624.2RS	HK0408TN	G4X8X2	ZM06
19	1.3	31	3X3X10	5,300	5,400	27	6,000	ZKLN0624.2RS	HK0408TN	G4X8X2	ZM06
19	1.3	31	3X3X10	5,300	5,400	27	6,000	ZKLN0624.2RS	HK0408TN	G4X8X2	ZM06
21	1.3	31	3X3X10	3,100	3,950	31	5,800	ZKLN0624.2RS	NK6/10TN	G6X12X2	ZM06
21	1.3	31	3X3X10	3,100	3,950	31	5,800	ZKLN0624.2RS	NK6/10TN	G6X12X2	ZM06
21	1.3	31	3X3X10	3,100	3,950	31	5,800	ZKLN0624.2RS	NK6/10TN	G6X12X2	ZM06
21	1.3	31	3X3X10	3,100	3,950	31	5,800	ZKLN0624.2RS	NK6/10TN	G6X12X2	ZM06
21	1.3	31	3X3X10	3,100	3,950	31	5,800	ZKLN0624.2RS	NK6/10TN	G6X12X2	ZM06
21	1.3	31	3X3X10	6,200	4,550	21	5,800	ZKLN0624.2RS	NK6/10TN	G6X12X2	ZM06
21	1.3	31	3X3X10	6,200	4,550	21	5,800	ZKLN0624.2RS	NK6/10TN	G6X12X2	ZM06
21	1.3	31	3X3X10	6,200	4,550	21	5,800	ZKLN0624.2RS	NK6/10TN	G6X12X2	ZM06
21	1.3	31	3X3X10	6,200	4,550	21	5,800	ZKLN0624.2RS	NK6/10TN	G6X12X2	ZM06
21	1.3	31	3X3X10	6,200	4,550	21	5,800	ZKLN0624.2RS	NK6/10TN	G6X12X2	ZM06
21	1.3	31	3X3X10	12,200	4,800	15	5,800	ZKLN0624.2RS	NK6/10TN	G6X12X2	ZM06
21	1.3	31	3X3X10	12,200	4,800	15	5,800	ZKLN0624.2RS	NK6/10TN	G6X12X2	ZM06
21	1.3	31	3X3X10	12,200	4,800	15	5,800	ZKLN0624.2RS	NK6/10TN	G6X12X2	ZM06
21	1.3	31	3X3X10	12,200	4,800	15	5,800	ZKLN0624.2RS	NK6/10TN	G6X12X2	ZM06
21	1.3	31	3X3X10	12,200	4,800	15	5,800	ZKLN0624.2RS	NK6/10TN	G6X12X2	ZM06
21	1.3	31	3X3X10	15,200	4,800	13	5,800	ZKLN0624.2RS	NK6/10TN	G6X12X2	ZM06
21	1.3	31	3X3X10	15,200	4,800	13	5,800	ZKLN0624.2RS	NK6/10TN	G6X12X2	ZM06
21	1.3	31	3X3X10	15,200	4,800	13	5,800	ZKLN0624.2RS	NK6/10TN	G6X12X2	ZM06
21	1.3	31	3X3X10	15,200	4,800	13	5,800	ZKLN0624.2RS	NK6/10TN	G6X12X2	ZM06
21	1.3	31	3X3X10	15,200	4,800	13	5,800	ZKLN0624.2RS	NK6/10TN	G6X12X2	ZM06

Planetary Roller Screw

RGT SERIES

- Split roller nut, preloaded
- Standard ends configuration

For details on part numbers, descriptive suffixes and various technical references, please refer to front of this section.

For engineering or technical information contact your local sales representative or call Distributor Sales (800)523-6572 or Linear Sales (800)462-3399.

DIMENSION TABLE (Contd.) - Dimensions in mm																
NOMINAL DIAMETER d_0	PART NUMBER d_0	PITCH P	STROKE H	MASS kg	DIMENSIONS - SCREW SHAFT											
					d_1 ISO h6	d_2	d_3 -0.005	d_4	d_5 ISO h6	l_0	l_1	l_2	l_3	l_4	l_5	
12	RGT 12.	1.	100	0.293	10	M12X1	12	18	10	220	20	33	53	161	20	
	RGT 12.	1.	200	0.382	10	M12X1	12	18	10	320	20	33	53	261	20	
	RGT 12.	1.	300	0.47	10	M12X1	12	18	10	420	20	33	53	361	20	
	RGT 12.	1.	400	0.559	10	M12X1	12	18	10	520	20	33	53	461	20	
	RGT 12.	1.	500	0.648	10	M12X1	12	18	10	620	20	33	53	561	20	
	RGT 12.	2.	100	0.293	10	M12X1	12	18	10	220	20	33	53	161	20	
	RGT 12.	2.	200	0.382	10	M12X1	12	18	10	320	20	33	53	261	20	
	RGT 12.	2.	300	0.47	10	M12X1	12	18	10	420	20	33	53	361	20	
	RGT 12.	2.	400	0.559	10	M12X1	12	18	10	520	20	33	53	461	20	
	RGT 12.	2.	500	0.648	10	M12X1	12	18	10	620	20	33	53	561	20	
	RGT 12.	4.	100	0.293	10	M12X1	12	18	10	220	20	33	53	161	20	
	RGT 12.	4.	200	0.382	10	M12X1	12	18	10	320	20	33	53	261	20	
	RGT 12.	4.	300	0.47	10	M12X1	12	18	10	420	20	33	53	361	20	
	RGT 12.	4.	400	0.559	10	M12X1	12	18	10	520	20	33	53	461	20	
	RGT 12.	4.	500	0.648	10	M12X1	12	18	10	620	20	33	53	561	20	
	RGT 12.	5.	100	0.293	10	M12X1	12	18	10	220	20	33	53	161	20	
	RGT 12.	5.	200	0.382	10	M12X1	12	18	10	320	20	33	53	261	20	
	RGT 12.	5.	300	0.47	10	M12X1	12	18	10	420	20	33	53	361	20	
	RGT 12.	5.	400	0.559	10	M12X1	12	18	10	520	20	33	53	461	20	
	RGT 12.	5.	500	0.648	10	M12X1	12	18	10	620	20	33	53	561	20	

1) Limiting speed of the planetary roller screw. Critical speed n_{max} and limiting speed of the rolling bearings should be considered.



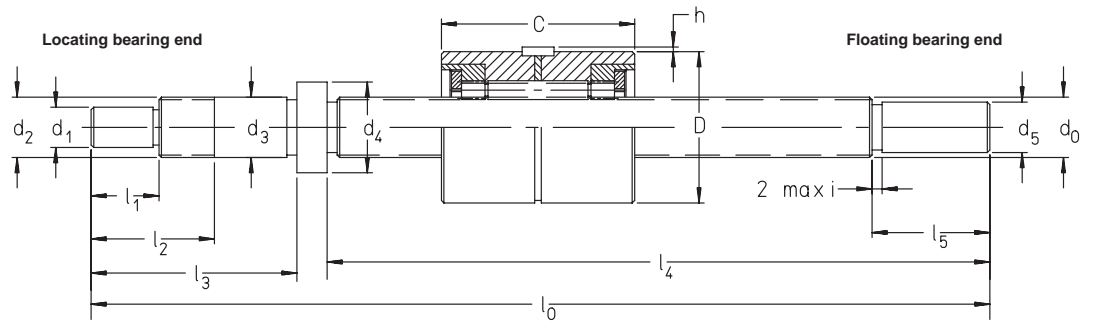

NUT			KEY TO DIN 6885	LOAD RATINGS		SPRING RATIO	LIMITING SPEED ¹⁾	LOCATING BEARING		FLOATING BEARING	SEAL	LOCK NUT
D ISO g6	h	C h12		dyn. C N	stat. C ₀ N	C _k N ^{2/3} / μm	n _g grease rpm	ZKLN1242.2RS	ZKLF1255.2RS	NK10/12TN	G10X17X3	ZM12
32	1.7	31	4X4X14	3,700	6,400	38	5,600	ZKLN1242.2RS	ZKLF1255.2RS	NK10/12TN	G10X17X3	ZM12
32	1.7	31	4X4X14	3,700	6,400	38	5,600	ZKLN1242.2RS	ZKLF1255.2RS	NK10/12TN	G10X17X3	ZM12
32	1.7	31	4X4X14	3,700	6,400	38	5,600	ZKLN1242.2RS	ZKLF1255.2RS	NK10/12TN	G10X17X3	ZM12
32	1.7	31	4X4X14	3,700	6,400	38	5,600	ZKLN1242.2RS	ZKLF1255.2RS	NK10/12TN	G10X17X3	ZM12
32	1.7	31	4X4X14	3,700	6,400	38	5,600	ZKLN1242.2RS	ZKLF1255.2RS	NK10/12TN	G10X17X3	ZM12
26	2	31	4X4X14	4,900	5,000	27	5,600	ZKLN1242.2RS	ZKLF1255.2RS	NK10/12TN	G10X17X3	ZM12
26	2	31	4X4X14	4,900	5,000	27	5,600	ZKLN1242.2RS	ZKLF1255.2RS	NK10/12TN	G10X17X3	ZM12
26	2	31	4X4X14	4,900	5,000	27	5,600	ZKLN1242.2RS	ZKLF1255.2RS	NK10/12TN	G10X17X3	ZM12
26	2	31	4X4X14	4,900	5,000	27	5,600	ZKLN1242.2RS	ZKLF1255.2RS	NK10/12TN	G10X17X3	ZM12
26	2	31	4X4X14	4,900	5,000	27	5,600	ZKLN1242.2RS	ZKLF1255.2RS	NK10/12TN	G10X17X3	ZM12
26	2	31	4X4X14	9,700	5,500	19	5,600	ZKLN1242.2RS	ZKLF1255.2RS	NK10/12TN	G10X17X3	ZM12
26	2	31	4X4X14	9,700	5,500	19	5,600	ZKLN1242.2RS	ZKLF1255.2RS	NK10/12TN	G10X17X3	ZM12
26	2	31	4X4X14	9,700	5,500	19	5,600	ZKLN1242.2RS	ZKLF1255.2RS	NK10/12TN	G10X17X3	ZM12
26	2	31	4X4X14	9,700	5,500	19	5,600	ZKLN1242.2RS	ZKLF1255.2RS	NK10/12TN	G10X17X3	ZM12
26	2	31	4X4X14	9,700	5,500	19	5,600	ZKLN1242.2RS	ZKLF1255.2RS	NK10/12TN	G10X17X3	ZM12
26	2	31	4X4X14	12,100	5,500	17	5,600	ZKLN1242.2RS	ZKLF1255.2RS	NK10/12TN	G10X17X3	ZM12
26	2	31	4X4X14	12,100	5,500	17	5,600	ZKLN1242.2RS	ZKLF1255.2RS	NK10/12TN	G10X17X3	ZM12
26	2	31	4X4X14	12,100	5,500	17	5,600	ZKLN1242.2RS	ZKLF1255.2RS	NK10/12TN	G10X17X3	ZM12
26	2	31	4X4X14	12,100	5,500	17	5,600	ZKLN1242.2RS	ZKLF1255.2RS	NK10/12TN	G10X17X3	ZM12
26	2	31	4X4X14	12,100	5,500	17	5,600	ZKLN1242.2RS	ZKLF1255.2RS	NK10/12TN	G10X17X3	ZM12

Planetary Roller Screw

RGT SERIES

- Split roller nut, preloaded
- Standard ends configuration

For details on part numbers, descriptive suffixes and various technical references, please refer to front of this section.

For engineering or technical information contact your local sales representative or call Distributor Sales (800)523-6572 or Linear Sales (800)462-3399.

DIMENSION TABLE (Contd.) · Dimensions in mm																
NOMINAL DIAMETER d_0	PART NUMBER d_0	PITCH P	STROKE H	MASS kg	DIMENSIONS – SCREW SHAFT											
					d_1 ISO h6	d_2	d_3 -0.005	d_4	d_5 ISO h6	l_0	l_1	l_2	l_3	l_4	l_5	
15	RGT 15.	2.	100	0.501	12	M15X1	15	22	12	224	20	31	53	165	20	
	RGT 15.	2.	200	0.64	12	M15X1	15	22	12	324	20	31	53	265	20	
	RGT 15.	2.	300	0.779	12	M15X1	15	22	12	424	20	31	53	365	20	
	RGT 15.	2.	400	0.917	12	M15X1	15	22	12	524	20	31	53	465	20	
	RGT 15.	2.	500	1.056	12	M15X1	15	22	12	624	20	31	53	565	20	
	RGT 15.	2.	600	1.195	12	M15X1	15	22	12	724	20	31	53	665	20	
	RGT 15.	4.	100	0.501	12	M15X1	15	22	12	224	20	31	53	165	20	
	RGT 15.	4.	200	0.64	12	M15X1	15	22	12	324	20	31	53	265	20	
	RGT 15.	4.	300	0.779	12	M15X1	15	22	12	424	20	31	53	365	20	
	RGT 15.	4.	400	0.917	12	M15X1	15	22	12	524	20	31	53	465	20	
	RGT 15.	4.	500	1.056	12	M15X1	15	22	12	624	20	31	53	565	20	
	RGT 15.	4.	600	1.195	12	M15X1	15	22	12	724	20	31	53	665	20	
	RGT 15.	5.	100	0.501	12	M15X1	15	22	12	224	20	31	53	165	20	
	RGT 15.	5.	200	0.64	12	M15X1	15	22	12	324	20	31	53	265	20	
	RGT 15.	5.	300	0.779	12	M15X1	15	22	12	424	20	31	53	365	20	
	RGT 15.	5.	400	0.917	12	M15X1	15	22	12	524	20	31	53	465	20	
	RGT 15.	5.	500	1.056	12	M15X1	15	22	12	624	20	31	53	565	20	
	RGT 15.	5.	600	1.195	12	M15X1	15	22	12	724	20	31	53	665	20	

1) Limiting speed of the planetary roller screw. Critical speed n_{max} and limiting speed of the rolling bearings should be considered.



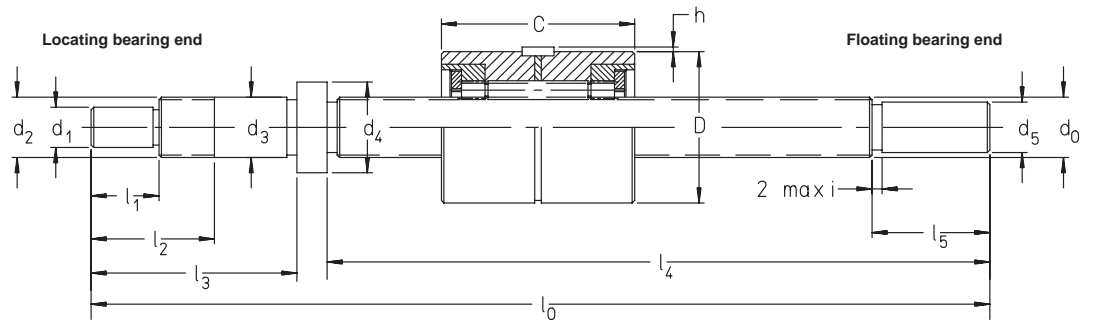

NUT			KEY TO DIN 6885	BASIC LOAD RATINGS		SPRING RATIO	LIMITING SPEED ¹⁾	LOCATING BEARING		FLOATING BEARING	SEAL	LOCK NUT
D ISO g6	h	C h12		dyn. C N	stat. C ₀ N	C _K N ^{2/3} / μm	n _g grease rpm					
34	1.7	35	4X4X14	6,100	8,000	34	5,500	ZKLN1545.2RS	ZKLF1560.2RS	NK12/12TN	G12X19X3	ZM15
34	1.7	35	4X4X14	6,100	8,000	34	5,500	ZKLN1545.2RS	ZKLF1560.2RS	NK12/12TN	G12X19X3	ZM15
34	1.7	35	4X4X14	6,100	8,000	34	5,500	ZKLN1545.2RS	ZKLF1560.2RS	NK12/12TN	G12X19X3	ZM15
34	1.7	35	4X4X14	6,100	8,000	34	5,500	ZKLN1545.2RS	ZKLF1560.2RS	NK12/12TN	G12X19X3	ZM15
34	1.7	35	4X4X14	6,100	8,000	34	5,500	ZKLN1545.2RS	ZKLF1560.2RS	NK12/12TN	G12X19X3	ZM15
34	1.7	35	4X4X14	6,100	8,000	34	5,500	ZKLN1545.2RS	ZKLF1560.2RS	NK12/12TN	G12X19X3	ZM15
34	1.7	35	4X4X14	12,200	8,900	24	5,500	ZKLN1545.2RS	ZKLF1560.2RS	NK12/12TN	G12X19X3	ZM15
34	1.7	35	4X4X14	12,200	8,900	24	5,500	ZKLN1545.2RS	ZKLF1560.2RS	NK12/12TN	G12X19X3	ZM15
34	1.7	35	4X4X14	12,200	8,900	24	5,500	ZKLN1545.2RS	ZKLF1560.2RS	NK12/12TN	G12X19X3	ZM15
34	1.7	35	4X4X14	12,200	8,900	24	5,500	ZKLN1545.2RS	ZKLF1560.2RS	NK12/12TN	G12X19X3	ZM15
34	1.7	35	4X4X14	12,200	8,900	24	5,500	ZKLN1545.2RS	ZKLF1560.2RS	NK12/12TN	G12X19X3	ZM15
34	1.7	35	4X4X14	15,200	9,100	21	5,500	ZKLN1545.2RS	ZKLF1560.2RS	NK12/12TN	G12X19X3	ZM15
34	1.7	35	4X4X14	15,200	9,100	21	5,500	ZKLN1545.2RS	ZKLF1560.2RS	NK12/12TN	G12X19X3	ZM15
34	1.7	35	4X4X14	15,200	9,100	21	5,500	ZKLN1545.2RS	ZKLF1560.2RS	NK12/12TN	G12X19X3	ZM15
34	1.7	35	4X4X14	15,200	9,100	21	5,500	ZKLN1545.2RS	ZKLF1560.2RS	NK12/12TN	G12X19X3	ZM15
34	1.7	35	4X4X14	15,200	9,100	21	5,500	ZKLN1545.2RS	ZKLF1560.2RS	NK12/12TN	G12X19X3	ZM15
34	1.7	35	4X4X14	15,200	9,100	21	5,500	ZKLN1545.2RS	ZKLF1560.2RS	NK12/12TN	G12X19X3	ZM15



Planetary Roller Screw

RGT SERIES

- Split roller nut, preloaded
- Standard ends configuration

For details on part numbers, descriptive suffixes and various technical references, please refer to front of this section.

For engineering or technical information contact your local sales representative or call Distributor Sales (800)523-6572 or Linear Sales (800)462-3399.

DIMENSION TABLE (Contd.) - Dimensions in mm																
NOMINAL DIAMETER d_0	PART NUMBER d_0	PITCH P	STROKE H	MASS kg	DIMENSIONS – SCREW SHAFT											
					d_1 ISO h6	d_2	d_3 -0.005	d_4	d_5 ISO h6	l_0	l_1	l_2	l_3	l_4	l_5	
20	RGT 20.	2.	400	1.713	12	M15X1	15	22	12	546	20	31	53	487	20	
	RGT 20.	2.	500	1.96	12	M15X1	15	22	12	646	20	31	53	587	20	
	RGT 20.	2.	600	2.207	12	M15X1	15	22	12	746	20	31	53	687	20	
	RGT 20.	2.	800	2.7	12	M15X1	15	22	12	946	20	31	53	887	20	
	RGT 20.	2.	1000	3.193	12	M15X1	15	22	12	1146	20	31	53	1087	20	
	RGT 20.	2.	1200	3.686	12	M15X1	15	22	12	1346	20	31	53	1287	20	
	RGT 20.	4.	400	1.713	12	M15X1	15	22	12	546	20	31	53	487	20	
	RGT 20.	4.	500	1.96	12	M15X1	15	22	12	646	20	31	53	587	20	
	RGT 20.	4.	600	2.207	12	M15X1	15	22	12	746	20	31	53	687	20	
	RGT 20.	4.	800	2.7	12	M15X1	15	22	12	946	20	31	53	887	20	
	RGT 20.	4.	1000	3.193	12	M15X1	15	22	12	1146	20	31	53	1087	20	
	RGT 20.	4.	1200	3.686	12	M15X1	15	22	12	1346	20	31	53	1287	20	
	RGT 20.	5.	400	1.713	12	M15X1	15	22	12	546	20	31	53	487	20	
	RGT 20.	5.	500	1.96	12	M15X1	15	22	12	646	20	31	53	587	20	
	RGT 20.	5.	600	2.207	12	M15X1	15	22	12	746	20	31	53	687	20	
	RGT 20.	5.	800	2.7	12	M15X1	15	22	12	946	20	31	53	887	20	
	RGT 20.	5.	1000	3.193	12	M15X1	15	22	12	1146	20	31	53	1087	20	
	RGT 20.	5.	1200	3.686	12	M15X1	15	22	12	1346	20	31	53	1287	20	
	RGT 20.	6.	400	1.713	12	M15X1	15	22	12	546	20	31	53	487	20	
	RGT 20.	6.	500	1.96	12	M15X1	15	22	12	646	20	31	53	587	20	
	RGT 20.	6.	600	2.207	12	M15X1	15	22	12	746	20	31	53	687	20	
	RGT 20.	6.	800	2.7	12	M15X1	15	22	12	946	20	31	53	887	20	
	RGT 20.	6.	1000	3.193	12	M15X1	15	22	12	1146	20	31	53	1087	20	
	RGT 20.	6.	1200	3.686	12	M15X1	15	22	12	1346	20	31	53	1287	20	

1) Limiting speed of the planetary roller screw. Critical speed n_{max} and limiting speed of the rolling bearings should be considered.



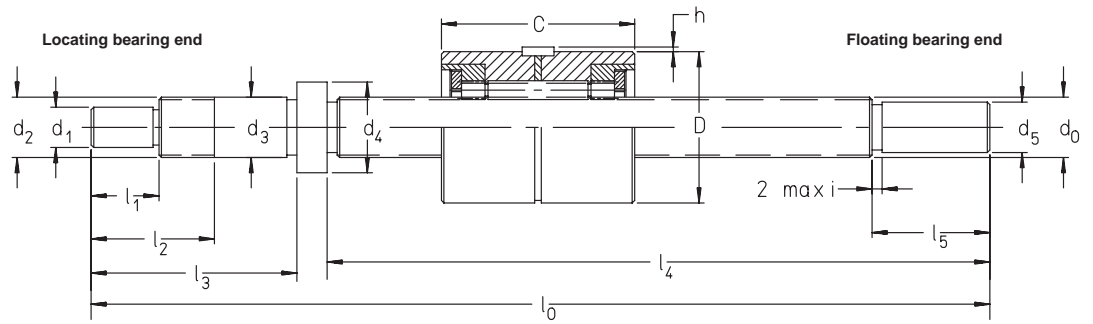

NUT			KEY TO DIN 6885	LOAD RATINGS		SPRING RATIO	LIMITING SPEED ¹⁾	LOCATING BEARING		FLOATING BEARING	SEAL	LOCK NUT
D ISO g6	h	C h12		dyn. C N	stat. C ₀ N	C _K N ^{2/3} / μm	n _g grease rpm					
42	1.7	55	4X4X18	10,900	21,800	61	5,200	ZKLN1545.2RS	ZKLF1560.2RS	NK12/12TN	G12X19X3	ZM15
42	1.7	55	4X4X18	10,900	21,800	61	5,200	ZKLN1545.2RS	ZKLF1560.2RS	NK12/12TN	G12X19X3	ZM15
42	1.7	55	4X4X18	10,900	21,800	61	5,200	ZKLN1545.2RS	ZKLF1560.2RS	NK12/12TN	G12X19X3	ZM15
42	1.7	55	4X4X18	10,900	21,800	61	5,200	ZKLN1545.2RS	ZKLF1560.2RS	NK12/12TN	G12X19X3	ZM15
42	1.7	55	4X4X18	10,900	21,800	61	5,200	ZKLN1545.2RS	ZKLF1560.2RS	NK12/12TN	G12X19X3	ZM15
42	1.7	55	4X4X18	10,900	21,800	61	5,200	ZKLN1545.2RS	ZKLF1560.2RS	NK12/12TN	G12X19X3	ZM15
42	1.7	55	4X4X18	10,900	21,800	61	5,200	ZKLN1545.2RS	ZKLF1560.2RS	NK12/12TN	G12X19X3	ZM15
42	1.7	55	4X4X18	21,700	25,000	42	5,200	ZKLN1545.2RS	ZKLF1560.2RS	NK12/12TN	G12X19X3	ZM15
42	1.7	55	4X4X18	21,700	25,000	42	5,200	ZKLN1545.2RS	ZKLF1560.2RS	NK12/12TN	G12X19X3	ZM15
42	1.7	55	4X4X18	21,700	25,000	42	5,200	ZKLN1545.2RS	ZKLF1560.2RS	NK12/12TN	G12X19X3	ZM15
42	1.7	55	4X4X18	21,700	25,000	42	5,200	ZKLN1545.2RS	ZKLF1560.2RS	NK12/12TN	G12X19X3	ZM15
42	1.7	55	4X4X18	21,700	25,000	42	5,200	ZKLN1545.2RS	ZKLF1560.2RS	NK12/12TN	G12X19X3	ZM15
42	1.7	55	4X4X18	21,700	25,000	42	5,200	ZKLN1545.2RS	ZKLF1560.2RS	NK12/12TN	G12X19X3	ZM15
42	1.7	55	4X4X18	27,000	26,000	38	5,200	ZKLN1545.2RS	ZKLF1560.2RS	NK12/12TN	G12X19X3	ZM15
42	1.7	55	4X4X18	27,000	26,000	38	5,200	ZKLN1545.2RS	ZKLF1560.2RS	NK12/12TN	G12X19X3	ZM15
42	1.7	55	4X4X18	27,000	26,000	38	5,200	ZKLN1545.2RS	ZKLF1560.2RS	NK12/12TN	G12X19X3	ZM15
42	1.7	55	4X4X18	27,000	26,000	38	5,200	ZKLN1545.2RS	ZKLF1560.2RS	NK12/12TN	G12X19X3	ZM15
42	1.7	55	4X4X18	27,000	26,000	38	5,200	ZKLN1545.2RS	ZKLF1560.2RS	NK12/12TN	G12X19X3	ZM15
42	1.7	55	4X4X18	27,000	26,000	38	5,200	ZKLN1545.2RS	ZKLF1560.2RS	NK12/12TN	G12X19X3	ZM15
42	1.7	55	4X4X18	32,500	26,500	34	5,200	ZKLN1545.2RS	ZKLF1560.2RS	NK12/12TN	G12X19X3	ZM15
42	1.7	55	4X4X18	32,500	26,500	34	5,200	ZKLN1545.2RS	ZKLF1560.2RS	NK12/12TN	G12X19X3	ZM15
42	1.7	55	4X4X18	32,500	26,500	34	5,200	ZKLN1545.2RS	ZKLF1560.2RS	NK12/12TN	G12X19X3	ZM15
42	1.7	55	4X4X18	32,500	26,500	34	5,200	ZKLN1545.2RS	ZKLF1560.2RS	NK12/12TN	G12X19X3	ZM15
42	1.7	55	4X4X18	32,500	26,500	34	5,200	ZKLN1545.2RS	ZKLF1560.2RS	NK12/12TN	G12X19X3	ZM15
42	1.7	55	4X4X18	32,500	26,500	34	5,200	ZKLN1545.2RS	ZKLF1560.2RS	NK12/12TN	G12X19X3	ZM15

Planetary Roller Screw

RGT SERIES

- Split roller nut, preloaded
- Special ends configuration*)

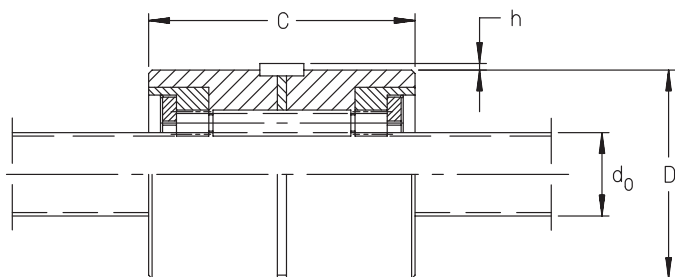

For details on part numbers, descriptive suffixes and various technical references, please refer to front of this section.

For engineering or technical information contact your local sales representative or call Distributor Sales (800)523-6572 or Linear Sales (800)462-3399.

DIMENSION TABLE - Dimensions in mm

NOMINAL DIAMETER d_0	PART NUMBER d_0	PITCH P	NUT DIMENSIONS			KEY TO DIN 6885	SPRING RATIO C_K N ^{2/3} / μm	LIMITING SPEED ¹⁾ n_g grease rpm	LOAD RATINGS		
			D ISO g6	h	C h12				dyn. C N	stat. C ₀ N	
24	RGT	24.	2	48	1.7	55	4X4X18	75	5,000	13,200	32,000
	RGT	24.	4	48	1.7	55	4X4X18	52	5,000	26,000	37,500
	RGT	24.	5	48	1.7	55	4X4X18	46	5,000	32,500	39,000
	RGT	24.	6	48	1.7	55	4X4X18	42	5,000	39,000	40,000
27	RGT	27.	2	55	1.7	55	4X4X18	76	4,900	13,400	35,000
	RGT	27.	4	55	1.7	55	4X4X18	53	4,900	26,500	41,500
	RGT	27.	5	55	1.7	55	4X4X18	47	4,900	33,000	43,000
	RGT	27.	6	55	1.7	55	4X4X18	43	4,900	39,500	44,500
	RGT	27.	8	55	1.7	55	4X4X18	37	4,900	53,000	45,500
30	RGT	30.	2	62	1.7	55	5X5X22	78	4,700	13,500	38,000
	RGT	30.	4	62	1.7	55	5X5X22	54	4,700	27,000	45,000
	RGT	30.	5	62	1.7	55	5X5X22	48	4,700	33,500	47,000
	RGT	30.	6	62	1.7	55	5X5X22	44	4,700	40,000	48,500
	RGT	30.	8	62	1.7	55	5X5X22	38	4,700	53,000	50,000
36	RGT	36.	2	75	1.7	68	5X5X22	108	4,400	18,300	65,000
	RGT	36.	4	75	1.7	68	5X5X22	74	4,400	36,000	78,000
	RGT	36.	5	75	1.7	68	5X5X22	65	4,400	45,000	82,000
	RGT	36.	6	75	1.7	68	5X5X22	59	4,400	54,000	85,000
	RGT	36.	8	75	1.7	68	5X5X22	51	4,400	72,000	89,000
39	RGT	39.	2	80	1.7	72	5X5X25	117	4,200	19,800	76,000
	RGT	39.	4	80	1.7	72	5X5X25	80	4,200	39,500	92,000
	RGT	39.	5	80	1.7	72	5X5X25	71	4,200	49,000	97,000
	RGT	39.	10	80	1.7	72	5X5X25	56	4,200	97,000	109,000
48	RGT	48.	5	96	2.7	95	6X6X40	91	3,800	62,000	155,000
	RGT	48.	10	96	2.7	95	6X6X40	63	3,800	124,000	178,000
63	RGT	63.	5	118	3.5	115	8X7X45	116	3,000	78,000	250,000
	RGT	63.	10	118	3.5	115	8X7X45	80	3,000	155,000	295,000

1) Limiting speed of the planetary roller screw. Critical speed n_{max} and limiting speed of the rolling bearings should be considered.

*) Available on request.

Planetary Roller Screw

RGT SERIES

- One-piece roller nut, not preloaded
- Special ends configuration*)

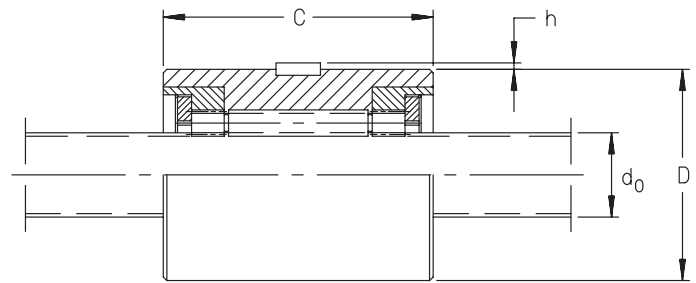

For details on part numbers, descriptive suffixes and various technical references, please refer to front of this section.

For engineering or technical information contact your local sales representative or call Distributor Sales (800)523-6572 or Linear Sales (800)462-3399.

DIMENSION TABLE - Dimensions in mm											
NOMINAL DIAMETER d_0	PART NUMBER d_0	PITCH P	NUT DIMENSIONS			KEY TO DIN 6885	SPRING RATIO C_K $N^{2/3} / \mu m$	LIMITING SPEED ¹⁾ n_g grease rpm	LOAD RATINGS		
			D ISO g6	h	C h12				dyn. C N	stat. C ₀ N	
24	RGT	24.	2	48	1.7	55	4X4X18	124	5,000	22,400	69,000
	RGT	24.	4	48	1.7	55	4X4X18	86	5,000	44,500	80,000
	RGT	24.	5	48	1.7	55	4X4X18	64	5,000	55,000	83,000
	RGT	24.	6	48	1.7	55	4X4X18	69	5,000	66,000	85,000
27	RGT	27.	2	55	1.7	55	4X4X18	127	4,900	22,700	75,000
	RGT	27.	4	55	1.7	55	4X4X18	87	4,900	45,000	88,000
	RGT	27.	5	55	1.7	55	4X4X18	78	4,900	56,000	92,000
	RGT	27.	6	55	1.7	55	4X4X18	71	4,900	67,000	94,000
	RGT	27.	8	55	1.7	55	4X4X18	61	4,900	89,000	98,000
30	RGT	30.	2	62	1.7	55	5X5X22	130	4,700	23,000	81,000
	RGT	30.	4	62	1.7	55	5X5X22	89	4,700	45,500	96,000
	RGT	30.	5	62	1.7	55	5X5X22	79	4,700	57,000	100,000
	RGT	30.	6	62	1.7	55	5X5X22	72	4,700	68,000	103,000
	RGT	30.	8	62	1.7	55	5X5X22	62	4,700	90,000	107,000
36	RGT	36.	2	75	1.7	68	5X5X22	176	4,400	31,000	136,000
	RGT	36.	4	75	1.7	68	5X5X22	121	4,400	61,000	165,000
	RGT	36.	5	75	1.7	68	5X5X22	107	4,400	76,000	173,000
	RGT	36.	6	75	1.7	68	5X5X22	97	4,400	91,000	179,000
	RGT	36.	8	75	1.7	68	5X5X22	84	4,400	121,000	188,000
39	RGT	39.	2	80	1.7	72	5X5X25	191	4,200	33,000	159,000
	RGT	39.	4	80	1.7	72	5X5X25	131	4,200	66,000	193,000
	RGT	39.	5	80	1.7	72	5X5X25	116	4,200	82,000	203,000
	RGT	39.	10	80	1.7	72	5X5X25	91	4,200	163,000	228,000
48	RGT	48.	5	96	2.7	95	6X6X40	148	3,800	104,000	320,000
	RGT	48.	10	96	2.7	95	6X6X40	103	3,800	206,000	370,000
63	RGT	63.	5	118	3.5	115	8X7X45	188	3,000	129,000	520,000
	RGT	63.	10	118	3.5	115	8X7X45	129	3,000	255,000	610,000

1) Limiting speed of the planetary roller screw. Critical speed n_{max} and limiting speed of the rolling bearings should be considered.

*) Available on request.

Rolled Ball Screws

SERIES KGS

- Metric dimensions
- High strength steel Cf53 (SAE1055)
- Induction hardened to 60 HRC
- Gothic arch thread form

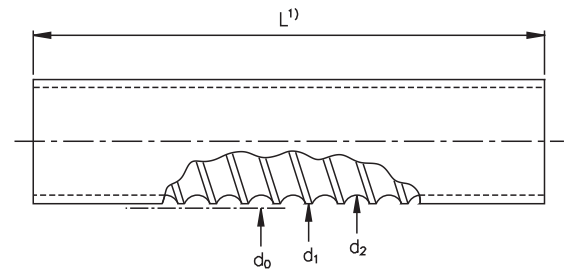

For details on part numbers, descriptive suffixes and various technical references, please refer to front of this section.
For engineering or technical information contact your local sales representative or call Distributor Sales (800)523-6572.

NOMINAL PITCH DIAMETER d_0	DESIGNATION	ACCURACY CLASS ($\mu\text{m}/300\text{ mm}$)	d_0 mm	Lead P mm	d_1 mm	d_2 mm	NUMBER OF STARTS	L_{max}^1 mm	MASS (kg/m)
16	KGS 1605	23 / 50	16	5	15.5	12.9	1	5600	1.26
	KGS 1610	23 / 50	16	10	15.4	13.0	2	5600	1.26
20	KGS 2005	23 / 50	20	5	19.5	16.9	1	5600	2.04
	KGS 2020	23 / 50	20	20	19.5	16.9	4	5600	2.07
	KGS 2050	23 / 50	20	50	19.1	16.5	5	5600	2.04
25	KGS 2505	23 / 50	25	5	24.5	21.9	1	5600	3.33
	KGS 2510	23 / 50	25	10	24.5	21.9	1	5600	3.33
	KGS 2520	23 / 50	25	20	24.6	22.0	4	5600	3.33
	KGS 2525	23 / 50	25	25	24.5	22.0	5	5600	3.33
	KGS 2550	23 / 50	25	50	24.5	21.5	5	5600	3.33
32	KGS 3205	23 / 50	32	5	31.5	28.9	1	5600	5.61
	KGS 3210	23 / 50	32	10	31.7	27.3	1	5600	5.60
	KGS 3220	23 / 50	32	20	31.7	27.9	2	5600	5.61
	KGS 3240	23 / 50	32	40	30.9	28.3	4	5600	5.61
40	KGS 4005	23 / 50	40	5	39.5	36.9	1	5600	9.03
	KGS 4010	23 / 50	40	10	39.5	34.1	2	5600	8.33
	KGS 4020	23 / 50	40	20	39.7	35.9	2	5600	9.01
	KGS 4040	23 / 50	40	40	38.9	36.3	4	5600	9.01
50	KGS 5010	50	50	10	49.5	44.1	1	5600	13.48
	KGS 5020	50	50	20	49.5	44.1	2	5600	13.50
63	KGS 6310	50	63	10	62.5	57.1	1	5600	22.04
	KGS 6320	50	63	20	62.5	57.1	2	5600	22.03



Flanged Ball Nuts SERIES KGF

- Metric dimensions
- Flange mounting
- Optimized internal ball return systems
- Buna contact seals
- Threaded lubrication port
- 3000 rpm speed limit

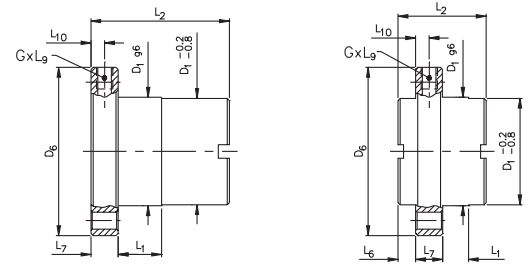

For details on part numbers, descriptive suffixes and various technical references, please refer to front of this section.
For engineering or technical information contact your local sales representative or call Distributor Sales (800)523-6572.

NOMINAL PITCH DIAMETER d_0	DESIGNATION d_0 LEAD	SEAL SUFFIX	FORM	HOLE PATTERN	D_1 mm	D_4 mm	D_5 mm	D_6 mm	L_1 mm	L_2 mm	L_6 mm	L_7 mm	L_8 mm	L_9 mm	L_{10} mm	LUBE HOLE G	AXIAL BACKLASH MAX	LOAD RATINGS	
																		DYN C (kN)	STAT C (kN)
16	KGF D 16 05	EE	E	1	28	38	5.5	48	10	42	-	10	40	10	5	M6	0.08	12.0	12.7
	KGF D 16 10	EE	E	1	28	38	5.5	48	10	55	-	10	40	10	5	M6	0.08	23.0	26.0
20	KGF N 20 05	EE	E	3	32	45	7	55	8	44	-	12	-	8	6	M6	0.08	14.0	17.0
	KGF N 20 20	EE	S	3	35	50	7	62	4	30	8	10	-	8	5	M6	0.08	12.0	19.2
	KGF N 20 50	EE	S	3	35	50	7	62	10	56	9	10	-	8	5	M6	0.15	18.0	22.0
25	KGF D 25 05	EE	E	1	40	51	6.6	62	10	42	-	10	48	10	5	M6	0.08	15.0	22.4
	KGF D 25 10	EE	E	1	40	51	6.6	62	16	55	-	10	48	10	5	M6	0.08	17.5	25.0
	KGF D 25 20	EE	S	1	40	51	6.6	62	4	35	10.5	10	48	8	5	M6	0.15	19.0	23.5
	KGF D 25 25	EE	S	1	40	51	6.6	62	9	35	8	10	- ¹⁾	8	5	M6	0.08	21.0	31.0
	KGF D 25 50	EE	S	1	40	51	6.6	62	10	58	10.5	10	48	8	5	M6	0.15	22.5	29.0
32	KGF N 32 05	EE	E	3	45	58	7	70	10	59	-	16	-	8	8	M6	0.08	24.0	49.0
	KGF N 32 10	EE	E	3	53	68	7	80	10	73	-	16	-	8	8	M8x1	0.08	44.0	53.0
	KGF D 32 20	EE	E	1	53	65	9	80	16	80	-	12	62	10	6	M6	0.08	42.5	61.0
	KGF N 32 40	EE	S	3	53	68	7	80	14	45	7.5	16	-	10	8	M6	0.08	17.0	32.0
40	KGF D 40 05	EE	E	2	63	78	9	93	10	57	-	14	70	10	7	M6	0.08	26.0	63.5
	KGF D 40 10	EE	E	2	63	78	9	95	16	71	-	14	70	10	7	M8x1	0.08	50.0	70.0
	KGF D 40 20	EE	E	2	63	78	9	93	16	80	-	14	70	10	7	M8x1	0.08	44.5	77.0
	KGF D 40 40	EE	S	2	63	78	9	93	16	85	7.5	14	- ¹⁾	10	7	M8x1	0.08	42.0	93.0
50	KGF D 50 10	EE	E	2	75	93	11	110	16	95	-	16	85	10	8	M8x1	0.08	78.0	153.0
	KGF D 50 20	EE	E	2	85	103	11	125	22	95	-	18	95	10	9	M8x1	0.08	82.0	137.0
63	KGF D 63 10	EE	E	2	90	108	11	125	16	97	-	18	95	10	9	M8x1	0.08	86.0	200.0
	KGF D 63 20	EE	E	2	95	115	13.5	135	25	99	-	20	100	10	10	M8x1	0.08	85.0	170.0

Notes
1) Round flange.

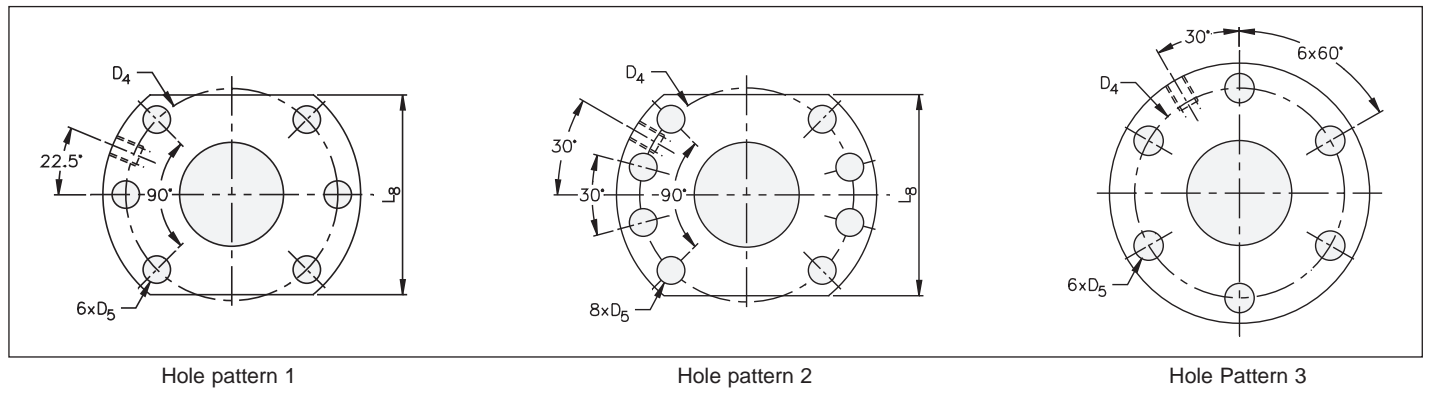

Hole pattern 1

Hole pattern 2

Hole Pattern 3



Cylindrical Ball Nuts

SERIES KGM

- Metric dimensions
- Cylindrical mounting
- Optimized internal ball return systems
- Buna contact seals
- Radial lubrication hole and groove
- 3000 rpm speed limit

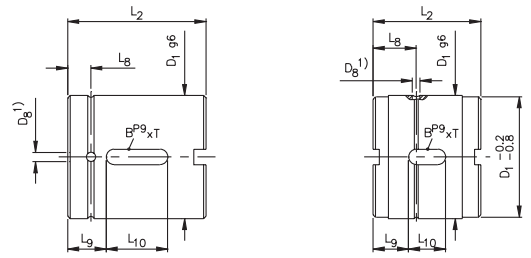

For details on part numbers, descriptive suffixes and various technical references, please refer to front of this section.
For engineering or technical information contact your local sales representative or call Distributor Sales (800)523-6572.

NOMINAL PITCH DIAMETER d ₀	DESIGNATION d ₀ LEAD	SEAL SUFFIX	FORM	D ₁ mm	D ₈ ¹⁾ mm	L ₂ mm	L ₈ mm	L ₉ mm	L ₁₀ mm	BxT	AXIAL BACKLASH MAX	LOAD RATINGS	
												DYN C (kN)	STAT C (kN)
16	KGM D 16 05	EE	E	28	3	34	7	7	20	5x2	0.08	12.5	12.7
	KGM D 16 10	EE	E	28	3	50	7	15	20	5x2	0.08	23.0	26.0
20	KGM N 20 05	EE	E	32	3	34	7	7	20	5x2	0.08	14.0	17.0
	KGM N 20 20	EE	S	35	1.5	30	11.5	9	12	5x3	0.08	12.0	19.2
	KGM N 20 50	EE	S	35	1.5	56	16	18	20	5x3	0.15	18.0	22.0
25	KGM D 25 05	EE	E	40	3	34	7	7	20	5x2	0.08	15.0	22.4
	KGM D 25 10	EE	E	40	3	45	7.5	12.5	20	5x2	0.08	17.5	25.0
	KGM D 25 20	EE	S	40	1.5	35	14	11.5	12	5x3	0.15	19.0	23.5
	KGM D 25 25	EE	S	40	1.5	35	11.5	11	13	5x3	0.08	21.0	31.0
	KGM D 25 50	EE	S	40	1.5	58	17	19	20	5x3	0.15	22.5	29.0
32	KGM N 32 05	EE	E	45	3	45	7.5	8	30	6x2.5	0.08	24.0	49.0
	KGM N 32 10	EE	E	53	4	60	10	15	30	6x2.5	0.08	44.0	53.0
	KGM N 32 20	EE	E	53	3	70	7.5	20	30	6x2.5	0.08	42.5	61.0
	KGM N 32 40	EE	S	53 ²⁾	1.5	45	13	10	25	6x4	0.08	17.0	32.0
40	KGM D 40 05	EE	E	63	3	45	7.5	8	30	6x2.5	0.08	26.0	63.5
	KGM D 40 10	EE	E	63	4	60	10	15	30	6x2.5	0.08	50.0	70.0
	KGM D 40 20	EE	E	63	3	70	7.5	20	30	6x2.5	0.08	44.5	77.0
	KGM D 40 40	EE	S	63	1.5	85	15	27.5	30	6x3.5	0.08	42.0	93.0
50	KGM D 50 10	EE	E	75	4	82	11	23	36	6x2.5	0.08	78.0	153.0
	KGM N 50 20	EE	E	85	4	82	10	23	36	6x2.5	0.08	82.0	137.0
63	KGM D 63 10	EE	E	90	4	82	11	23	36	6x2.5	0.08	86.0	200.0
	KGM D 63 20	EE	E	95	4	82	10	23	36	6x2.5	0.08	85.0	170.0

Notes
1) Position of lubrication hole not defined on circumference.
2) D1 -0.2/-0.8 is D1 -1/-1.5

Standard Screw Ends FORM D

- “Fixed” drive end support configuration
- Designed for INA ballscrew support bearings and locknuts
- Locknut threads to 6g tolerance class
- Standard metric keyways

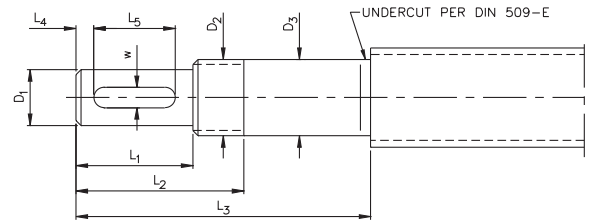

For details on part numbers, descriptive suffixes and various technical references, please refer to front of this section.
For engineering or technical information contact your local sales representative or call Distributor Sales (800)523-6572.

NOMINAL PITCH DIAMETER d_0	D_1^{k6} mm	D_2 mm	D_3^{k6} mm	L_1 mm	L_2 mm	L_3 mm	L_4 mm	KEYWAY TO DIN 6885 w x depth x L_6
16	9	M12x1	12	20	30	55	2.5	3 x 1.8 x 16
20	11	M15x1	15	23	33	58	3.5	4 x 2.5 x 16
25	14	M20x1	20	30	42	70	4	5 x 3 x 22
32	19	M25x1.5	25	40	54	82	6	6 x 3.5 x 28
40	24	M30x1.5	30	50	64	92	7	8 x 4 x 36

NOMINAL PITCH DIAMETER d_0	D_4 mm	D_5 mm	D_6 mm	D_7 mm	L_6 mm	L_7 mm	N x S mm	BEARING		LOCKNUT	MAX. AXIAL LOAD (kN)
16	55	42	22	42	8	25	3 x M6	ZKLF 1255.2RS	ZKLN 1242.2RS	ZM12	12
20	60	46	25	45	8	25	3 x M6	ZKLF 1560.2RS	ZKLN 1545.2RS	ZM15	14
25	68	53	32	52	10	28	4 x M6	ZKLF 2068.2RS	ZKLN 2052.2RS	ZM20	16
32	75	58	38	57	12	28	4 x M6	ZKLF 2575.2RS	ZKLN 2557.2RS	ZM25	20
40	80	63	45	62	12	28	6 x M6	ZKLF 3080.2RS	ZKLN 3062.2RS	ZM30	22

Notes

Bearings and locknut must be ordered separately. For more information, see INA publication ZAE.

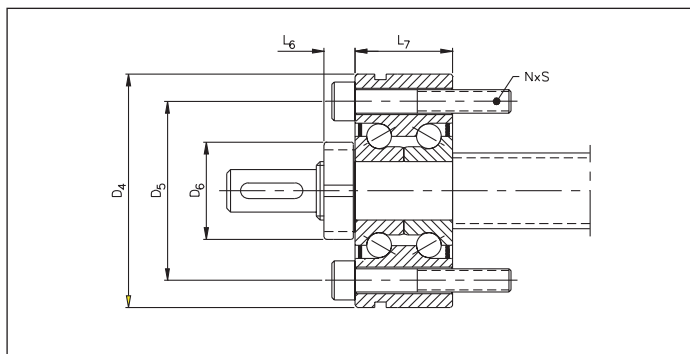

Form D with 2KLF and 2M

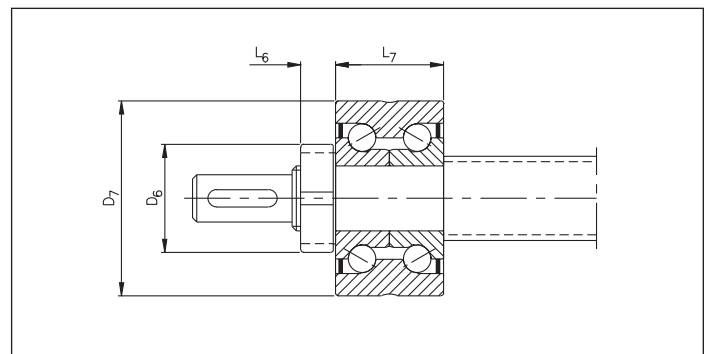

Form D with 2KLN and 2M

Standard Screw Ends FORM W AND N AND Z

- Radial end support configurations W & N
- Designed for INA bearings and retaining rings
- Form Z - cut and chamfer only

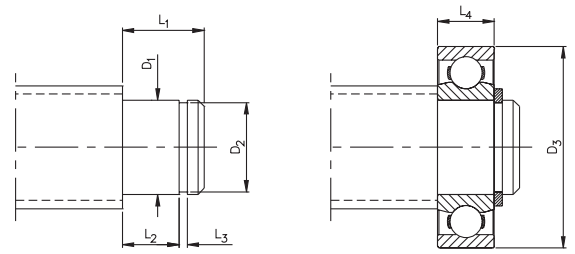

Form W

For details on part numbers, descriptive suffixes and various technical references, please refer to front of this section.
For engineering or technical information contact your local sales representative or call Distributor Sales (800)523-6572.

Form W

NOMINAL PITCH DIAMETER d_0	D_1^{k6} mm	D_2 mm	D_3 mm	L_1 mm	L_2 mm	L_3 mm	L_4 mm	BEARING	SHAFT RING PER DIN 471
16	12	11.5	28	12	8	1.1	8	6001 2RS	12x1
20	15	14.2	32	13	9	1.3	9	6002 2RS	15x1
25	20	18.8	42	16	12	1.3	12	6004 2RS	20x1.2
32	25	23.7	52	20	15	1.3	15	6205 2RS	25x1.2
40	30	28.6	62	21	16	1.6	16	6206 2RS	30x1.5
50	40	38.5	80	25	18	1.85	18	6208 2RS	40x1.75
63	55	52	100	29	21	2.15	21	6211 2RS	55x2

Notes

Bearings must be ordered separately. For more information, see INA publication 517.
Shaft rings not included.

Form N

NOMINAL PITCH DIAMETER d_0	D_1^{k6} mm	D_2 mm	D_3 mm	L_1 mm	L_2 mm	L_3 mm	L_4 mm	INA NEEDLE ROLLER BEARING	INA SNAP RING
16	12	11.5	24	18	14	1.1	13	NA 4901 2RS	WR 12
20	15	14.4	28	18	14	1.3	13	NA 4902 2RS	WR 15
25	20	19.2	37	22	18	1.3	17	NA 4904 2RS	WR 20
32	25	24	42	23	18	1.3	17	NA 4905 2RS	WR 25
40	30	29	47	23	18	1.6	17	NA 4906 2RS	WR 30
50	40	38.5	62	30	23	1.6	22	NA 4908 2RS	WR 40
63	50	48.5	62	30.5	23	1.6	22	NA 4910 2RS	WR 50

Notes

Bearings must be ordered separately. For more information, see INA publication 517.
Shaft rings not included.

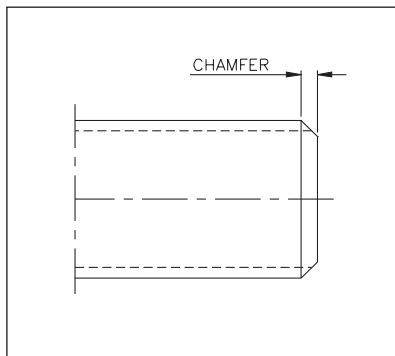

Form Z

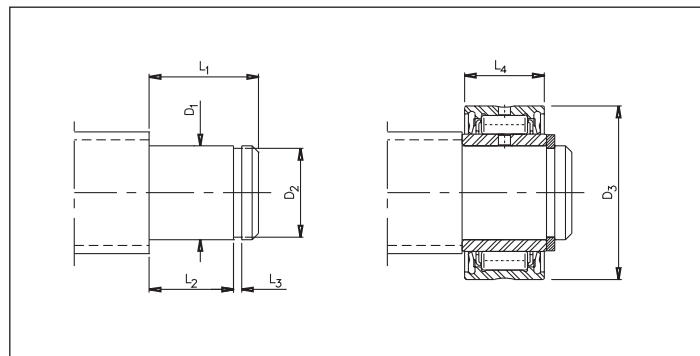

Form N

INA-HYDREL

Flat Cage Assemblies

FF, H, BF, HR SERIES

- Single row

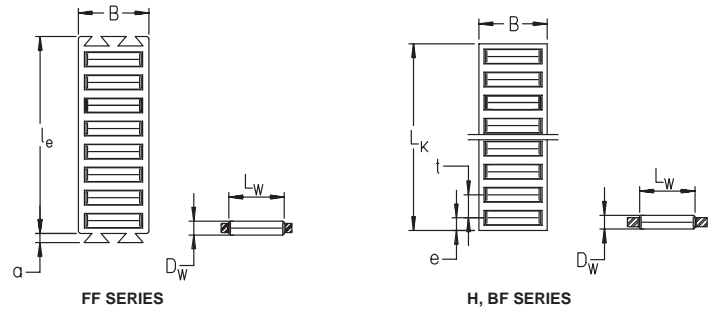

For details on part numbers, descriptive suffixes and various technical references, please refer to front of this section.

For engineering or technical information contact your local sales representative or call Distributor Sales (800)523-6572 or Linear Sales (800)462-3399.

PART NUMBER				WGT.	B	D _w	L _w	t	e	a	L _k max.	l ₃	Z _e ROLLERS PER CAGE	DYN. LOAD PER 10 ROLLERS C	STAT. LOAD PER 10 ROLLERS C ₀
				g/L _k =1000 mm	mm	mm	mm	mm	mm	mm	mm	mm	Number	N	N
FF2010	–	–	–	46	10	2	6.8	–	–	2	–	32	7	11800	28000
–	H10	–	–	63	10	2	6.8	4.5	3.5	–	3000	–	–	11800	28000
FF2515	–	–	–	84	15	2.5	9.8	–	–	2.5	–	45	8	21200	52000
–	H15	–	–	120	15	2.5	9.8	5	3.5	–	3000	–	–	21200	52000
FF3020	–	–	–	148	20	3	13.8	–	–	3	–	60	9	35500	88000
–	H20	–	–	202	20	3	13.8	6	4.5	–	3000	–	–	35500	88000
–	–	BF3020	–	342	20	3	15.8	6	4.5	–	2000	–	–	39500	102000
FF3525	–	–	–	221	25	3.5	17.8	–	–	3	–	75	10	53000	132000
–	H25	–	–	294	25	3.5	17.8	7	5	–	3000	–	–	53000	132000
–	–	BF5015	–	375	15	5	11.8	8	5.5	–	2000	–	–	60000	123000
–	–	BF5023	–	530	23	5	19.8	8	5.5	–	2000	–	–	91000	211000
–	–	BF5032	–	722	32	5	27.8	8	5.5	–	2000	–	–	119000	300000
–	–	–	HR50	105	10.5	5	5	10	6.5	–	3000	–	–	30000	51000
–	–	BF7028	–	875	28	7	24	11	7.5	–	2000	–	–	165000	365000
–	–	BF7035	–	1080	35	7	30	11	7.5	–	2000	–	–	197000	455000
–	–	–	HR70	295	17	7	10	13	8.5	–	3000	–	–	82000	148000
–	–	–	HR100	598	24	10	14	17	10	–	3000	–	–	169000	295000
–	–	BF12022	–	1220	22	12	18	16	10	–	2000	–	–	260000	460000
–	–	BF12040	–	1970	40	12	36	16	10	–	2000	–	–	455000	930000

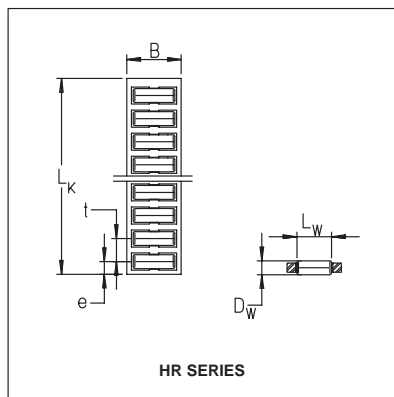

Products and company names are trademarks or registered trademarks of their respective companies.



INA-HYDREL

Flat Cage Assemblies

FF..ZW, H..ZW, HR..ZW SERIES

- Double row

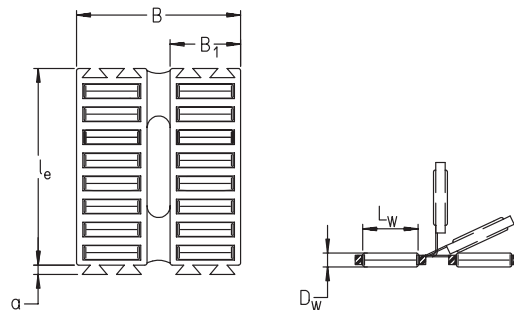

FF..ZW SERIES

For details on part numbers, descriptive suffixes and various technical references, please refer to front of this section.

For engineering or technical information contact your local sales representative or call Distributor Sales (800)523-6572 or Linear Sales (800)462-3399.

PART NUMBER			WGT.	B	B ₁	D _w	L _w	t	e	a	L _k max.	I ₃	Z _e ROLLERS PER CAGE	DYN. LOAD PER 10 ROLLERS C	STAT. LOAD PER 10 ROLLERS C ₀
			g/L _k =1000 mm	mm	mm	mm	mm	mm	mm	mm	mm	mm	Number	N	N
FF 2025 ZWA	–	–	94	25	10	2	6.8	–	–	2	–	32	7	20200	56000
–	H 24 ZW	–	138	24	10.5	2	6.8	4.5	3.5	–	3000	–	–	20200	56000
FF 2535 ZW	–	–	182	35	15	2.5	9.8	–	–	2.4	–	45	8	36500	103000
–	H 34 ZW	–	239	33.5	14.3	2.5	9.8	5.5	4	–	3000	–	–	36500	103000
FF 3045 ZW	–	–	315	45	20	3	13.8	–	–	3	–	60	9	61000	177000
–	H 44 ZW	–	408	44	19	3	13.8	6	4.5	–	3000	–	–	61000	177000
FF 3555 ZW	–	–	464	55	25	3.5	17.8	–	–	3.2	–	75	10	90000	265000
–	H 55 ZW	–	598	55	24	3.5	17.8	7	5	–	3000	–	–	90000	265000
–	–	HR 50 ZW	215	24	10.5	5	5	10	6.5	–	3000	–	–	51000	101000
–	–	HR 70 ZW	602	40	17	7	10	13	8.5	–	3000	–	–	141000	295000
–	–	HR 100 ZW	1233	55	24	10	14	17	10	–	3000	–	–	290000	590000

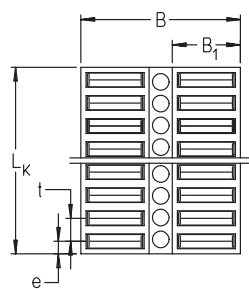

H..ZW SERIES

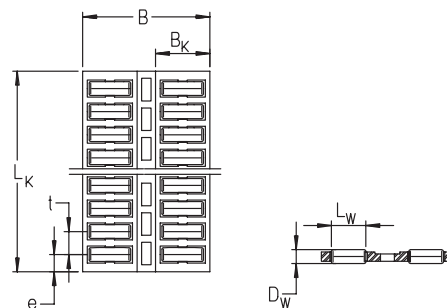

HR..ZW SERIES

INA-HYDREL

Angled Flat Cage Assemblies

FFW, HW, HRW SERIES

- Double row with 90° bend

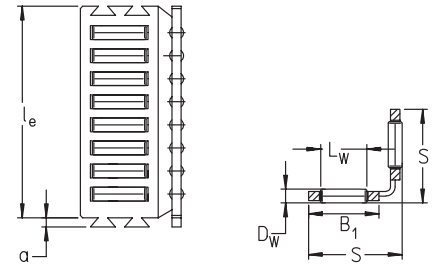

FFW SERIES

For details on part numbers, descriptive suffixes and various technical references, please refer to front of this section.

For engineering or technical information contact your local sales representative or call Distributor Sales (800)523-6572 or Linear Sales (800)462-3399.

PART NUMBER			WGT.	S	B ₁	D _w	L _w	t	e	a	L _k max.	l ₃	Z _e ROLLERS PER CAGE	DYN. LOAD PER 10 ROLLERS C	STAT. LOAD PER 10 ROLLERS C ₀
			g/L _k =1000 mm	mm	mm	mm	mm	mm	mm	mm	mm	mm	Number	N	N
FFW 2025 ZWA	HW10	–	219	10	8	2	4.8	4	3	–	1000	–	–	10700	27400
	–	–	94	15	10	2	6.8	–	–	2	–	32	7	14300	40000
	HW15	–	138	15	10.5	2	6.8	4.5	3.5	–	3000	–	–	14300	40000
FFW 2535	–	–	182	20.5	15	2.5	9.8	–	–	2.4	–	45	8	25500	73000
	HW20	–	239	20	14.3	2.5	9.8	5.5	4	–	3000	–	–	25500	73000
FFW 3045	–	–	315	26	20	3	13.8	–	–	3	–	60	9	43000	125000
	HW25	–	408	25	19	3	13.8	6	4.5	–	3000	–	–	43000	125000
FFW 3555	–	–	464	31.5	25	3.5	17.8	–	–	3.2	–	75	10	64000	187000
	HW30	–	598	30	24	3.5	17.8	7	5	–	3000	–	–	64000	187000
–	–	HRW 50	215	15.5	10.5	5	5	10	6.5	–	3000	–	–	36500	72000
–	–	HRW 70	602	25	17	7	10	13	8.5	–	3000	–	–	99000	209000
–	–	HRW100	1233	34	24	10	14	17	10	–	3000	–	–	205000	415000

The basic load ratings are valid for the condition that the two sections of the cage are symmetrical to the load direction (see diagram below).

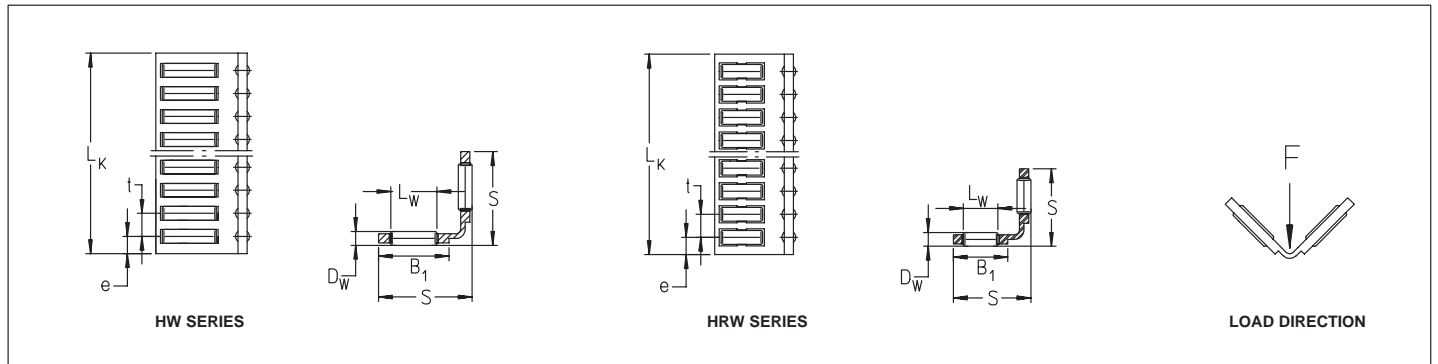

HW SERIES

HRW SERIES

LOAD DIRECTION

NOTES

